

Rules for the Classification of Floating Offshore Units at Fixed Locations and Mobile Offshore Drilling Units

Effective from 1 January 2024

Part E

Service Notations

GENERAL CONDITIONS

Definitions:

“*Administration*” means the Government of the State whose flag the Ship is entitled to fly or under whose authority the Ship is authorised to operate in the specific case.

“*IACS*” means the International Association of Classification Societies.

“*Interested Party*” means the party, other than the Society, having an interest in or responsibility for the Ship, product, plant or system subject to classification or certification (such as the owner of the Ship and his representatives, the ship builder, the engine builder or the supplier of parts to be tested) who requests the Services or on whose behalf the Services are requested.

“*Owner*” means the registered owner, the ship owner, the manager or any other party with the responsibility, legally or contractually, to keep the ship seaworthy or in service, having particular regard to the provisions relating to the maintenance of class laid down in Part A, Chapter 2 of the Rules for the Classification of Ships or in the corresponding rules indicated in the specific Rules.

“*Rules*” in these General Conditions means the documents below issued by the Society:

- (i) Rules for the Classification of Ships or other special units;
- (ii) Complementary Rules containing the requirements for product, plant, system and other certification or containing the requirements for the assignment of additional class notations;
- (iii) Rules for the application of statutory rules, containing the rules to perform the duties delegated by Administrations;
- (iv) Guides to carry out particular activities connected with Services;
- (v) Any other technical document, as for example rule variations or interpretations.

“*Services*” means the activities described in Article 1 below, rendered by the Society upon request made by or on behalf of the Interested Party.

“*Ship*” means ships, boats, craft and other special units, as for example offshore structures, floating units and underwater craft.

“*Society*” or “*TASNEEF*” means Tasneef and/or all the companies in the Tasneef Group which provide the Services.

“*Surveyor*” means technical staff acting on behalf of the Society in performing the Services.

Article 1

1.1. The purpose of the Society is, among others, the classification and certification of ships and the certification of their parts and components. In particular, the Society:

- (i) sets forth and develops Rules;
- (ii) publishes the Register of Ships;
- (iii) issues certificates, statements and reports based on its survey activities.

1.2. The Society also takes part in the implementation of national and international rules and standards as delegated by various Governments.

1.3. The Society carries out technical assistance activities on request and provides special services outside the scope of classification, which are regulated by these general conditions, unless expressly excluded in the particular contract.

Article 2

2.1. The Rules developed by the Society reflect the level of its technical knowledge at the time they are published. Therefore, the Society, although committed also through its research and development services to continuous updating of the Rules, does not guarantee the Rules meet state-of-the-art science and technology at the time of publication or that they meet the Society's or others' subsequent technical developments.

2.2. The Interested Party is required to know the Rules on the basis of which the Services are provided. With particular reference to Classification Services, special attention is to be given to the Rules concerning class suspension, withdrawal and reinstatement. In case of doubt or inaccuracy, the Interested Party is to promptly contact the Society for clarification.

The Rules for Classification of Ships are published on the Society's website: www.tasneef.ae.

2.3. The Society exercises due care and skill:

- (i) in the selection of its Surveyors
- (ii) in the performance of its Services, taking into account the level of its technical knowledge at the time the Services are performed.

2.4. Surveys conducted by the Society include, but are not limited to, visual inspection and non-destructive testing. Unless otherwise required, surveys are conducted through sampling techniques and do not consist of comprehensive verification or monitoring of the Ship or of the items subject to certification. The surveys and checks made by the Society on board ship do not necessarily require the constant and continuous presence of the Surveyor. The Society may also commission laboratory testing, underwater inspection and other checks carried out by and under the responsibility of qualified service suppliers. Survey practices and procedures are selected by the Society based on its experience and knowledge and according to generally accepted technical standards in the sector.

Article 3

3.1. The class assigned to a Ship, like the reports, statements, certificates or any other document or information issued by the Society, reflects the opinion of the Society concerning compliance, at the time the Service is provided, of the Ship or product subject to certification, with the applicable Rules (given the intended use and within the relevant time frame).

The Society is under no obligation to make statements or provide information about elements or facts which are not part of the specific scope of the Service requested by the Interested Party or on its behalf.

3.2. No report, statement, notation on a plan, review, Certificate of Classification, document or information issued or given as part of the Services provided by the Society shall have any legal effect or implication other than a representation that, on the basis of the checks made by the Society, the Ship, structure, materials, equipment, machinery or any other item covered by such document or information meet the Rules. Any such document is issued solely for the use of the Society, its committees and clients or other duly authorised bodies and for no other purpose. Therefore, the Society cannot be held liable for any act made or document issued by other parties on the basis of the statements or information given by the Society. The validity, application, meaning and interpretation of a Certificate of Classification, or any other document or information issued by the Society in connection with its Services, is governed by the Rules of the Society, which is the sole subject entitled to make such interpretation. Any disagreement on technical matters between the Interested Party and the Surveyor in the carrying out of his functions shall be raised in writing as soon as possible with the Society, which will settle any divergence of opinion or dispute.

3.3. The classification of a Ship, or the issuance of a certificate or other document connected with classification or certification and in general with the performance of Services by the Society shall have the validity conferred upon it by the Rules of the Society at the time of the assignment of class or issuance of the certificate; in no case shall it amount to a statement or warranty of seaworthiness,

structural integrity, quality or fitness for a particular purpose or service of any Ship, structure, material, equipment or machinery inspected or tested by the Society.

3.4. Any document issued by the Society in relation to its activities reflects the condition of the Ship or the subject of certification or other activity at the time of the check.

3.5. The Rules, surveys and activities performed by the Society, reports, certificates and other documents issued by the Society are in no way intended to replace the duties and responsibilities of other parties such as Governments, designers, ship builders, manufacturers, repairers, suppliers, contractors or sub-contractors, Owners, operators, charterers, underwriters, sellers or intended buyers of a Ship or other product or system surveyed.

These documents and activities do not relieve such parties from any fulfilment, warranty, responsibility, duty or obligation (also of a contractual nature) expressed or implied or in any case incumbent on them, nor do they confer on such parties any right, claim or cause of action against the Society. With particular regard to the duties of the ship Owner, the Services undertaken by the Society do not relieve the Owner of his duty to ensure proper maintenance of the Ship and ensure seaworthiness at all times. Likewise, the Rules, surveys performed, reports, certificates and other documents issued by the Society are intended neither to guarantee the buyers of the Ship, its components or any other surveyed or certified item, nor to relieve the seller of the duties arising out of the law or the contract, regarding the quality, commercial value or characteristics of the item which is the subject of transaction.

In no case, therefore, shall the Society assume the obligations incumbent upon the above-mentioned parties, even when it is consulted in connection with matters not covered by its Rules or other documents.

In consideration of the above, the Interested Party undertakes to relieve and hold harmless the Society from any third party claim, as well as from any liability in relation to the latter concerning the Services rendered.

Insofar as they are not expressly provided for in these General Conditions, the duties and responsibilities of the Owner and Interested Parties with respect to the services rendered by the Society are described in the Rules applicable to the specific Service rendered.

Article 4

4.1. Any request for the Society's Services shall be submitted in writing and signed by or on behalf of the Interested Party. Such a request will be considered irrevocable as soon as received by the Society and shall entail acceptance by the applicant of all relevant requirements of the Rules, including these General Conditions. Upon acceptance of the written request by the Society, a contract between the Society and the Interested Party is entered into, which is regulated by the present General Conditions.

4.2. In consideration of the Services rendered by the Society, the Interested Party and the person requesting the service shall be jointly liable for the payment of the relevant fees, even if the service is not concluded for any cause not pertaining to the Society. In the latter case, the Society shall not be held liable for non-fulfilment or partial fulfilment of the Services requested. In the event of late payment, interest at the legal current rate increased by 1.5% may be demanded.

4.3. The contract for the classification of a Ship or for other Services may be terminated and any certificates revoked at the request of one of the parties, subject to at least 30 days' notice to be given in writing. Failure to pay, even in part, the fees due for Services carried out by the Society will entitle the Society to immediately terminate the contract and suspend the Services.

For every termination of the contract, the fees for the activities performed until the time of the termination shall be owed to the Society as well as the expenses incurred in view of activities already programmed; this is without prejudice to the right to compensation due to the Society as a consequence of the termination.

With particular reference to Ship classification and certification, unless decided otherwise by the Society, termination of the contract implies that the assignment of class to a Ship is withheld or, if already assigned, that it is suspended or withdrawn; any statutory certificates issued by the Society will be withdrawn in those cases where provided for by agreements between the Society and the flag State.

Article 5

5.1. In providing the Services, as well as other correlated information or advice, the Society, its Surveyors, servants or agents operate with due diligence for the proper execution of the activity. However, considering the nature of the activities performed (see art. 2.4), it is not possible to guarantee absolute accuracy, correctness and completeness of any information or advice supplied. Express and implied warranties are specifically disclaimed.

Therefore, except as provided for in paragraph 5.2 below, and also in the case of activities carried out by delegation of Governments, neither the Society nor any of its Surveyors will be liable for any loss, damage or expense of whatever nature sustained by any person, in tort or in contract, derived from carrying out the Services.

5.2. Notwithstanding the provisions in paragraph 5.1 above, should any user of the Society's Services prove that he has suffered a loss or damage due to any negligent act or omission of the Society, its Surveyors, servants or agents, then the Society will pay compensation to such person for his proved loss, up to, but not exceeding, five times the amount of the fees charged for the specific services, information or opinions from which the loss or damage derives or, if no fee has been charged, a maximum of AED5,000 (Arab Emirates Dirhams Five Thousand only). Where the fees charged are related to a number of Services, the amount of the fees will be apportioned for the purpose of the calculation of the maximum compensation, by reference to the estimated time involved in the performance of the Service from which the damage or loss derives. Any liability for indirect or consequential loss, damage or expense is specifically excluded. In any case, irrespective of the amount of the fees charged, the maximum damages payable by the Society will not be more than AED5,000,000 (Arab Emirates Dirhams Five Millions only). Payment of compensation under this paragraph will not entail any admission of responsibility and/or liability by the Society and will be made without prejudice to the disclaimer clause contained in paragraph 5.1 above.

5.3. Any claim for loss or damage of whatever nature by virtue of the provisions set forth herein shall be made to the Society in writing, within the shorter of the following periods: (i) THREE (3) MONTHS from the date on which the Services were performed, or (ii) THREE (3) MONTHS from the date on which the damage was discovered. Failure to comply with the above deadline will constitute an absolute bar to the pursuit of such a claim against the Society.

Article 6

6.1. These General Conditions shall be governed by and construed in accordance with United Arab Emirates (UAE) law, and any dispute arising from or in connection with the Rules or with the Services of the Society, including any issues concerning responsibility, liability or limitations of liability of the Society, shall be determined in accordance with UAE law. The courts of the Dubai International Financial Centre (DIFC) shall have exclusive jurisdiction in relation to any claim or dispute which may arise out of or in connection with the Rules or with the Services of the Society.

6.2. However,

- (i) In cases where neither the claim nor any counterclaim exceeds the sum of AED300,000 (Arab Emirates Dirhams Three Hundred Thousand) the dispute shall be referred to the jurisdiction of the DIFC Small Claims Tribunal; and
- (ii) for disputes concerning non-payment of the fees and/or expenses due to the Society for services, the Society shall have the

right to submit any claim to the jurisdiction of the Courts of the place where the registered or operating office of the Interested Party or of the applicant who requested the Service is located.

In the case of actions taken against the Society by a third party before a public Court, the Society shall also have the right to summon the Interested Party or the subject who requested the Service before that Court, in order to be relieved and held harmless according to art. 3.5 above.

Article 7

7.1. All plans, specifications, documents and information provided by, issued by, or made known to the Society, in connection with the performance of its Services, will be treated as confidential and will not be made available to any other party other than the Owner without authorisation of the Interested Party, except as provided for or required by any applicable international, European or domestic legislation, Charter or other IACS resolutions, or order from a competent authority. Information about the status and validity of class and statutory certificates, including transfers, changes, suspensions, withdrawals of class, recommendations/conditions of class, operating conditions or restrictions issued against classed ships and other related information, as may be required, may be published on the website or released by other means, without the prior consent of the Interested Party.

Information about the status and validity of other certificates and statements may also be published on the website or released by other means, without the prior consent of the Interested Party.

7.2. Notwithstanding the general duty of confidentiality owed by the Society to its clients in clause 7.1 above, the Society's clients hereby accept that the Society may participate in the IACS Early Warning System which requires each Classification Society to provide other involved Classification Societies with relevant technical information on serious hull structural and engineering systems failures, as defined in the IACS Early Warning System (but not including any drawings relating to the ship which may be the specific property of another party), to enable such useful information to be shared and used to facilitate the proper working of the IACS Early Warning System. The Society will provide its clients with written details of such information sent to the involved Classification Societies.

7.3. In the event of transfer of class, addition of a second class or withdrawal from a double/dual class, the Interested Party undertakes to provide or to permit the Society to provide the other Classification Society with all building plans and drawings, certificates, documents and information relevant to the classed unit, including its history file, as the other Classification Society may require for the purpose of classification in compliance with the applicable legislation and relative IACS Procedure. It is the Owner's duty to ensure that, whenever required, the consent of the builder is obtained with regard to the provision of plans and drawings to the new Society, either by way of appropriate stipulation in the building contract or by other agreement.

In the event that the ownership of the ship, product or system subject to certification is transferred to a new subject, the latter shall have the right to access all pertinent drawings, specifications, documents or information issued by the Society or which has come to the knowledge of the Society while carrying out its Services, even if related to a period prior to transfer of ownership.

Article 8

8.1. Should any part of these General Conditions be declared invalid, this will not affect the validity of the remaining provisions.

EXPLANATORY NOTE TO PART E

1. Reference edition

The reference edition of these Rules is the edition effective from 01 January 2015.

2. Effective date of the requirements

2.1 All requirements in which new or amended provisions with respect to those contained in the reference edition have been introduced are followed by a date shown in brackets.

The date shown in brackets is the effective date of entry into force of the requirements as amended by the last updating. The effective date of all those requirements not followed by any date shown in brackets is that of the reference edition.

2.2 Item 5 below provides a summary of the technical changes from the preceding edition. In general, this list does not include those items to which only editorial changes have been made not affecting the effective date of the requirements contained therein.

3. Rule Variations and Corrigenda

Until the next edition of the Rules is published, Rule Variations and/or corrigenda, as necessary, will be published on the Tasneef web site (www.tasneef.ae). Except in particular cases, paper copies of Rule Variations or corrigenda are not issued.

4. Rule subdivision and cross-references

4.1 Rule subdivision

The Rules are subdivided into six parts, from A to F.

Part A: Classification and Surveys

Part B: Hull and Stability

Part C: Machinery, Systems and Fire Protection

Part D: Materials and Welding

Part E: Service Notations

Part F: Additional Class Notations

Each Part consists of:

- Chapters
- Sections and possible Appendices
- Articles
- Sub-articles
- Requirements

Figures (abbr. Fig) and Tables (abbr. Tab) are numbered in ascending order within each Section or Appendix.

5.2 Cross-references

Examples: Pt A, Ch 1, Sec 1, [3.2.1] or Pt A, Ch 1, App 1, [3.2.1]

- Pt A means Part A

The part is indicated when it is different from the part in which the cross-reference appears. Otherwise, it is not indicated.

- Ch 1 means Chapter 1

The Chapter is indicated when it is different from the chapter in which the cross-reference appears. Otherwise, it is not indicated.

- Sec 1 means Section 1 (or App 1 means Appendix 1)

The Section (or Appendix) is indicated when it is different from the Section (or Appendix) in which the cross-reference appears. Otherwise, it is not indicated.

- [3.2.1] refers to requirement 1, within sub-article 2 of article 3.

Cross-references to an entire Part or Chapter are not abbreviated as indicated in the following examples:

- Part A for a cross-reference to Part A
- Part A, Chapter 1 for a cross-reference to Chapter 1 of Part A.

5. Summary of amendments

Foreword

The date of entry into force of each new or amended item is shown in brackets after the number of the item concerned.



RULES FOR THE CLASSIFICATION OF FLOATING OFFSHORE UNITS AT FIXED LOCATIONS AND MOBILE OFFSHORE DRILLING UNITS

Part E Service Notations

Chapters **1 2 3 4 5 6**

Chapter 1	FSO
Chapter 2	FPSO
Chapter 3	FSRU
Chapter 4	MODU
Chapter 5	FLNG
Chapter 6	FPU

CHAPTER 1

FSO

Section 1 General

1	General	40
1.1	Application	
1.2	Summary table	

Section 2 Unit Arrangement

1	General arrangement design	41
1.1	General	
2	Access arrangement	41
2.1	General	
2.2	Access to pipe tunnel and opening arrangement	
2.3	Access to compartments in the cargo area	
2.4	Access to the bow	

Section 3 Hull and Stability

1	General	43
1.1		
2	Intact stability	43
2.1	General requirements	
2.2	Liquid transfer operation	
2.3	Weather criterion	
2.4	Alternative stability criteria	
3	Closing appliances	44
3.1	General requirements	
4	Watertight integrity	44
4.1		
5	Freeboard	44
5.1		
6	Structure design principles	45
6.1	Framing arrangement	
6.2	Bulkhead structural arrangement	
7	Design loads	45
7.1	Hull girder loads	
7.2	Local loads	

8	Hull scantlings	45
	8.1 Plating	
	8.2 Ordinary stiffeners	
	8.3 Primary supporting members	
	8.4 Strength check with respect to stresses due to the temperature gradient	
9	Other structures	49
	9.1 Opening arrangement	
10	Construction and testing	50
	10.1 Welding and weld connections	

Section 4 Machinery and Systems in Cargo Area

1	General	51
	1.1 Application	
	1.2 Documentation to be submitted	
2	Cargo tank venting systems	52
	2.1 Principle	
3	Cargo tank purging and/or gas-freeing	53
	3.1 General	
4	Cargo tank level gauging systems	53
	4.1 General	
5	Protection against tank overload	54
	5.1 General	
6	Tank washing systems	54
	6.1 General	
7	Heating systems intended for cargo tanks and other users in cargo area	54
	7.1 General	
8	Bilge system in cargo area	55
	8.1 General	
	8.2 Drainage of cofferdams and void spaces located within cargo area	
	8.3 Drainage of cofferdams located at the fore and aft ends of cargo tanks	
	8.4 Drainage of pump rooms	
	8.5 Drainage of tunnels and pump rooms other than cargo pump rooms	
9	Ballast system in cargo area	56
	9.1 General	
	9.2 Pumping arrangement for ballast tanks within cargo area	
	9.3 Emergency discharge of ballast	
	9.4 Ballast water in cargo tanks	
	9.5 Pumping arrangement for cofferdams located at the fore and aft ends of the cargo tanks	
	9.6 Ballast systems for fore peak	
	9.7 Ballast pipes passing through tanks	

10	Air and sounding pipes of spaces other than cargo tanks in cargo area	57
	10.1 General	
	10.2 Air pipes	
	10.3 Passage through cargo tanks	
11	Scupper pipes in cargo area	57
	11.1	
12	Certification, inspection and testing	57
	12.1 Application	
	12.2 Workshop tests	
	12.3 Shipboard tests	

Section 5 Electrical Installations

1	General	59
	1.1 Application	
	1.2 Documentation to be submitted	
	1.3 Monitoring of circuit in hazardous areas	
	1.4 Precautions against inlet of gases or vapours	
2	Hazardous location classification and permitted electrical equipment	59
	2.1 General	
	2.2 Ventilation	
	2.3 Protection in overpressure	
	2.4 Hazardous area and electrical equipment	
3	Sources of electrical power and distribution systems	60
	3.1 Power sources location	

Section 6 Fire Protection, Detection and Extinction

1	General	66
	1.1 Application	
	1.2 Documentation to be submitted	
2	Cargo area	66
	2.1 Separation of cargo oil tanks	
	2.2 Restriction on boundary openings	
	2.3	
3	Structural fire protection	67
	3.1	
4	Ventilation systems in hazardous spaces	67
	4.1 Ventilation of other enclosed or semi-enclosed spaces within tank area	
	4.2 Ventilation of cargo pump rooms	
5	Active fire protection	67
	5.1 Fixed deck foam system	
	5.2 Protection of cargo pump rooms	
	5.3 Protection of other enclosed spaces within the cargo tank deck area	

6	Fire and gas detection	69
	6.1 Gas detection system	
7	Personnel protection	69
	7.1 Firefighter's outfits	
8	Inert gas system	69
	8.1 Application	
	8.2 General requirements for inert gas systems	
	8.3 Requirements for equivalent systems	

Appendix 1 Devices to Prevent the Passage of Flame into the Cargo Tanks

1	General	70
	1.1 Application	
	1.2 Definitions	
	1.3 Instruction manual	
2	Design of the devices	71
	2.1 Principles	
	2.2 Mechanical design	
	2.3 Performance	
	2.4 Flame screens	
	2.5 Marking of devices	
3	Sizing, location and installation of devices	72
	3.1 Sizing of devices	
	3.2 Location and installation of devices	
4	Type test procedures	73
	4.1 Principles	
	4.2 Test procedure for flame arresters located at openings to the atmosphere	
	4.3 Test procedures for high velocity vents	
	4.4 Test rig and test procedures for detonation flame arresters located in-line	
	4.5 Operational test procedure	
	4.6 Laboratory report	

Appendix 2 Design of Crude Oil Washing Systems

1	General	78
	1.1 Application	
2	Design and installation	78
	2.1 Piping	
	2.2 Tank washing machines	
	2.3 Pumps	
	2.4 Ballast lines	
3	Testing	79
	3.1 Piping	

CHAPTER 2

FPSO

Section 1 General

1	General	82
	1.1 Application	
	1.2 Summary table	

Section 2 Unit Arrangement

1	General arrangement design	83
	1.1 General	
2	Access arrangement	83
	2.1 General	
	2.2 Access to pipe tunnel and opening arrangement	
	2.3 Access to compartments in the cargo area	
	2.4 Access to the bow	

Section 3 Hull and Stability

1	General	85
	1.1	
2	Intact stability	85
	2.1 General requirements	
	2.2 Liquid transfer operation	
	2.3 Weather criterion	
	2.4 Alternative stability criteria	
3	Closing appliances	86
	3.1 General requirements	
4	Watertight integrity	86
	4.1	
5	Freeboard	86
	5.1	
6	Structure design principles	87
	6.1 Framing arrangement	
	6.2 Bulkhead structural arrangement	
7	Design loads	87
	7.1 Hull girder loads	
	7.2 Local loads	

8	Hull scantlings	87
	8.1 Plating	
	8.2 Ordinary stiffeners	
	8.3 Primary supporting members	
	8.4 Strength check with respect to stresses due to the temperature gradient	
9	Other structures	91
	9.1 Opening arrangement	
10	Construction and testing	92
	10.1 Welding and weld connections	

Section 4 Machinery and Systems in Cargo Area

1	General	93
	1.1 Application	
	1.2 Documentation to be submitted	
2	Cargo tank venting systems	94
	2.1 Principle	
3	Cargo tank purging and/or gas-freeing	95
	3.1 General	
4	Cargo tank level gauging systems	95
	4.1 General	
5	Protection against tank overload	96
	5.1 General	
6	Tank washing systems	96
	6.1 General	
7	Heating systems intended for cargo tanks and other users in cargo area	96
	7.1 General	
8	Bilge system in cargo area	97
	8.1 General	
	8.2 Drainage of cofferdams and void spaces located within cargo area	
	8.3 Drainage of cofferdams located at the fore and aft ends of cargo tanks	
	8.4 Drainage of pump rooms	
	8.5 Drainage of tunnels and pump rooms other than cargo pump rooms	
9	Ballast system in cargo area	98
	9.1 General	
	9.2 Pumping arrangement for ballast tanks within cargo area	
	9.3 Emergency discharge of ballast	
	9.4 Ballast water in cargo tanks	
	9.5 Pumping arrangement for cofferdams located at the fore and aft ends of the cargo tanks	
	9.6 Ballast systems for fore peak	
	9.7 Ballast pipes passing through tanks	

10	Air and sounding pipes of spaces other than cargo tanks in cargo area	99
	10.1 General	
	10.2 Air pipes	
	10.3 Passage through cargo tanks	
11	Scupper pipes in cargo area	99
	11.1	
12	Certification, inspection and testing	99
	12.1 Application	
	12.2 Workshop tests	
	12.3 Shipboard tests	

Section 5 Electrical Installations

1	General	101
	1.1 Application	
	1.2 Documentation to be submitted	
	1.3 Definitions	
	1.4 Monitoring of circuit in hazardous areas	
	1.5 Precautions against inlet of gases or vapours	
2	Hazardous location classification and permitted electrical equipment	101
	2.1 General	
	2.2 Ventilation	
	2.3 Protection in overpressure	
	2.4 Hazardous area and electrical equipment	
	2.5 Process plant location classification and permitted electrical equipment	
3	Sources of electrical power and distribution systems	104
	3.1 Power sources location	

Section 6 Safety Systems

1	General	110
	1.1 Purpose and application	
	1.2 Documents to be submitted	
2	Fire and gas detection	110
	2.1 General requirements	
3	Emergency shut down systems	110
	3.1 General requirements and definitions	
	3.2 Basic design principles	
	3.3 Design and functional requirements	
	3.4 Automatic and manual shutdown	
	3.5 Electrical equipment for use in an emergency	

Section 7 Fire Protection, Detection and Extinction

1	General	112
	1.1 Application	
	1.2 Documentation to be submitted	
2	Cargo area	113
	2.1 Separation of cargo oil tanks	
	2.2 Restrictions on boundary openings	
	2.3	
3	Structural fire protection	113
	3.1	
4	Ventilation systems in hazardous spaces	113
	4.1 Ventilation of other enclosed or semi-enclosed spaces within tank area	
	4.2 Ventilation of cargo pump rooms	
5	Active fire protection	113
	5.1 Fixed fire extinguishing systems water demand	
	5.2 Fixed deck foam system	
	5.3 Protection of cargo pump rooms	
	5.4 Protection of other enclosed spaces within the cargo tank deck area	
	5.5 Protection of production area	
6	Fire and gas detection	115
	6.1 Fire detection and alarm system	
	6.2 Gas detection system	
7	Personnel protection	116
	7.1 Firefighter's outfits	
8	Inert gas system	116
	8.1 Application	
	8.2 General requirements for inert gas systems	
	8.3 Requirements for equivalent systems	

Appendix 1 Devices to Prevent the Passage of Flame into the Cargo Tanks

1	General	117
	1.1 Application	
	1.2 Definitions	
	1.3 Instruction manual	
2	Design of the devices	118
	2.1 Principles	
	2.2 Mechanical design	
	2.3 Performance	
	2.4 Flame screens	
	2.5 Marking of devices	
3	Sizing, location and installation of devices	119
	3.1 Sizing of devices	
	3.2 Location and installation of devices	

4	Type test procedures	119
4.1	Principles	
4.2	Test procedure for flame arresters located at openings to the atmosphere	
4.3	Test procedures for high velocity vents	
4.4	Test rig and test procedures for detonation flame arresters located in-line	
4.5	Operational test procedure	
4.6	Laboratory report	

Appendix 2 Design of Crude Oil Washing Systems

1	General	125
1.1	Application	
2	Design and installation	125
2.1	Piping	
2.2	Tank washing machines	
2.3	Pumps	
2.4	Ballast lines	
3	Testing	126
3.1	Piping	

CHAPTER 3

FSRU

Section 1 General

1	Scope	130
1.1	Applicability	
2	Documentation to be submitted	130
2.1		
3	Cargo equipment trials	130
3.1	Scope	
3.2	Extent of the tests	

Section 2 Stability

1	General	133
1.1		
2	Intact stability	133
2.1	General requirements IGC CODE REFERENCE : Ch 2, 2.2.2	
2.2	Weather criterion IGC CODE REFERENCE : Ch 2, 2.2.2	
2.3	Alternative stability criteria IGC CODE REFERENCE : Ch 2, 2.2.2	
3	Location of cargo tanks	134
3.1	Deck cargo tanks	

Section 3 Unit Arrangement

1	Segregation of the cargo area	135
1.1	Segregation of hold spaces	
1.2	Cargo containment systems not requiring secondary barriers	
1.3	Cargo containment systems requiring secondary barriers	
2	Accommodation, service and machinery spaces and control stations	135
2.1	General	
3	Cargo pump rooms and cargo compressor rooms	135
3.1	Location of cargo pump rooms and cargo compressor rooms	
4	Access arrangement	136
4.1	Access to compartments in the cargo area	

5	Air-locks	138
	5.1 Arrangement	
	5.2 Alarm	
	5.3 Electrical equipment	
	5.4 Ventilation	
6	Bilge, ballast and fuel oil arrangements	138
	6.1 Drainage arrangement	
	6.2 Additional requirements relative to the bilge system	
7	Bow or stern loading and unloading arrangements	139
	7.1 Locations of stopping devices for cargo pumps and compressors	

Section 4 Cargo Containment

1	Definitions	140
	1.1 Design pressure in harbour conditions	
	1.2 Design temperature	
2	Design loads	140
	2.1 Internal pressure for integral tanks, membrane tanks and type A independent tanks	
	2.2 Internal pressure for type B and C independent tanks	
3	Hull scantlings	141
	3.1 Plating	
	3.2 Ordinary stiffeners	
	3.3 Primary supporting members	
4	Structural analysis of integral tanks	142
	4.1 Scantlings	
5	Structural analysis of membrane tanks	142
	5.1 General	
	5.2 Scantlings	
6	Structural analysis of type A independent tanks	142
	6.1 Scantlings	
7	Structural analysis of type B independent tanks	142
	7.1 Plating and ordinary stiffeners	
	7.2 Primary supporting members	
	7.3 Fatigue analysis	
	7.4 Crack propagation analysis	
8	Structural analysis of type C independent tanks	147
	8.1 Stiffening rings in way of tank supports	
9	Supports	147
	9.1 Structural arrangement	
	9.2 Calculation of reaction forces in way of tank supports	
	9.3 Keys	
	9.4 Scantlings of type C independent tank supports and hull structures in way	

10	Secondary barrier	148
	10.1 Secondary barrier extent	
11	Insulation	148
	11.1 Heating of structures	
12	Materials	149
	12.1 Insulation material characteristics	
13	Construction and testing	149
	13.1 Integral tank testing	
	13.2 Membrane and semi-membrane tanks testing	
	13.3 Independent tank testing	
	13.4 Final tests	
14	Structural details	149
	14.1 Special structural details	
	14.2 Connections of the inner hull plating with intermediate plating	
	14.3 Connections of inner bottom with transverse cofferdam bulkheads	
	14.4 Cut-outs and connections	

Section 5 Regasification Systems, Process Pressure Vessels and Liquid, Vapour and Pressure Piping Systems

1	Regasification systems	151
	1.1 General	
	1.2 Design and construction	
2	Process pressure vessels	151
	2.1	
3	Cargo and process piping	151
	3.1 General	
	3.2 Design pressure	
	3.3 Flanges	
	3.4 Stress analysis	
	3.5 Aluminised pipes	
4	Cargo system valving requirements	153
	4.1 Cargo tank connections for gauging	
	4.2 Emergency shutdown	
5	Cargo transfer methods	153
	5.1 Discharge into common header	
6	Bonding	153
	6.1 Static electricity	
7	Integrated cargo and ballast system	154
	7.1 General	

Section 6 Materials for Construction

1	Material requirements	155
	1.1 Tubes, forgings and castings for cargo and process piping	
	1.2 Aluminium coatings	
2	Welding and non-destructive testing	155
	2.1 Welding consumables	
	2.2 Test requirements	

Section 7 Cargo Pressure/Temperature Control

1	Cargo Pressure/Temperature Control	156
	1.1 General	
2	Additional requirements for refrigerating plants	156
	2.1	
3	Reliquefaction plant of FRSU	156
	3.1 Mechanical refrigeration fitted as the primary system for cargo pressure control	
	3.2 Mechanical refrigeration fitted as a secondary system for cargo pressure control	
4	Cargo Compressor Systems	156
	4.1 Cargo compressors	
	4.2 Cargo Compressor Drives	
5	Oxidation Systems	157
	5.1	

Section 8 Cargo Tank Venting System

1	Pressure relief systems	158
	1.1 Interbarrier spaces	
	1.2 Vents	
	1.3 Segregation of vents	
	1.4 Back pressure	
2	Additional pressure relieving system for liquid level control	159
	2.1 General	

Section 9 Environmental Control

1	Inerting	160
	1.1 General	
2	Inert gas production on board	160
	2.1 Exemptions	

Section 10 Electrical Installations

1	General	161
	1.1	Application
	1.2	Definitions
	1.3	Monitoring of circuit in hazardous areas
	1.4	Precautions against inlet of gases or vapours
2	Hazardous location classification and permitted electrical equipment	161
	2.1	General
	2.2	Ventilation
	2.3	Hazardous area and electrical equipment
	2.4	Process plant location classification and permitted electrical equipment
3	Sources of electrical power and distribution systems	163
	3.1	Power sources location

Section 11 Safety System and Fire Protection

1	Fire and gas detection	168
	1.1	General
2	Emergency shut down system	168
	2.1	Drawings to be submitted
	2.2	General requirements and definitions
	2.3	Basic design principles
	2.4	Design and functional requirements
	2.5	Automatic and manual shutdown
	2.6	Electrical equipment for use in an emergency
3	Fire protection, detection and extinction	170
	3.1	General
	3.2	Water spray system

Section 12 Mechanical Ventilation in the Cargo Area

1	General	171
	1.1	Application
2	Spaces required to be entered during normal cargo handling operations	171
	2.1	Location of discharges from dangerous spaces
	2.2	Recirculation prevention
3	Spaces not normally entered	171
	3.1	General requirements

Section 13 Instrumentation (Gauging, Gas Detection)

1	General	172
	1.1 Cargo tank instrumentation	
	1.2 Detection of leak through secondary barrier	
	1.3 Indicator location	
2	Level indicators for cargo tanks	172
	2.1 General	
3	Overflow control	172
	3.1 Overflow alarm and shutdown	
4	Pressure gauges	173
	4.1 Pressure gauges in cargo tanks	
5	Temperature indicating devices	173
	5.1 General	
6	Gas detection requirements	173
	6.1 Position of sampling heads	
	6.2 Gas sampling lines	
	6.3 Protected spaces	
	6.4 Portable gas detectors	

Section 14 Protection of Personnel

1	Personnel protection requirements for individual products	174
	1.1 Showers and eye wash	

Section 15 Filling Limits for Cargo Tanks

1	General	175
	1.1	

Section 16 Use of Cargo as Fuel

1	Gas fuel supply	176
	1.1 Piping	
	1.2 Valves	
2	Gas make-up plant and related storage tanks	176
	2.1 General	
	2.2 Compressors	
	2.3 Heaters	
3	Special requirements for boilers	177
	3.1 Boiler arrangement	
	3.2 Combustion chamber	
	3.3 Burner system	

4	Special requirements for gas fired internal combustion engines and gas fired turbines	177
---	---	-----

- 4.1 Gas fuel supply to engine
- 4.2 Gas fuel supply piping systems
- 4.3 Shut-off of gas fuel supply
- 4.4 Emergency stop of dual fuel engines
- 4.5 Gas fuel make-up plant and related storage tanks
- 4.6 Requirements on dual fuel engines

Section 17 Special Requirements

1	General	179
---	---------	-----

- 1.1

Section 18 Operating Requirements

1	General	180
---	---------	-----

- 1.1

Section 19 Summary of Minimum Requirements

1	Additional information on products	181
---	------------------------------------	-----

- 1.1

CHAPTER 4

MODU

Section 1 General

1	General	184
1.1	Application	
1.2	Summary table	
1.3	Definition	

Section 2 Hull

1	General analysis and design principles	187
1.1	Methods of analysis and calculation	
1.2	Design	
2	Environmental conditions	188
2.1	General	
2.2	Acceptability of the parameters defining the design environmental conditions	
2.3	Recurrence periods and environmental conditions	
2.4	Parameters relevant to environmental phenomena	
3	Environmental conditions and design loads	192
3.1	General	
3.2	Gravity loads	
3.3	Functional loads	
3.4	Environmental loads	
3.5	Additional loads	
4	Structural analysis	195
4.1		
5	Safety factors and permissible stresses	197
5.1		
6	Special design principles applied to surface units	198
6.1	Hull	
7	Special design principles applied to self-elevating units	198
7.1	Hull	
7.2	Wave clearance	
7.3	Legs	
7.4	Pre-loading capability of legs	
7.5	Structures connecting legs to hull	
7.6	Bottom mat	
7.7	Sea-bed conditions	
7.8	Deckhouses	

8	Special design principles applied to column stabilized units	199
	8.1 General	
	8.2 Wave clearance of upper deck	
	8.3 Upper deck	
	8.4 Columns, lower hulls and footings	
	8.5 Bracing members	
	8.6 Structural redundancy	
	8.7 Fatigue analysis	

Section 3 Stability

1	General	202
	1.1 Application	
	1.2 Document to be submitted	
2	Inclining test	202
	2.1	
3	Righting moment and heeling moment curves	202
	3.1	
4	Intact stability criteria	204
	4.1	
5	Subdivision and damage stability	205
	5.1 Surface and self-elevating units	
	5.2 Column-stabilized units	
	5.3 All types of units	
	5.4	
6	Extent of damage	207
	6.1 Surface units	
	6.2 Self-elevating units	
	6.3 Column stabilized units	
7	Watertight integrity	208
	7.1 General	
	7.2 Tank boundaries	
8	Closing appliances	208
	8.1 General requirements related to intact stability	
	8.2 General requirements related to damage stability	
9	Freeboard	209
	9.1 General	
	9.2 Surface units	
	9.3 Self-elevating units	
	9.4 Column-stabilized units	

Section 4 Machinery

1	Machinery installations for all types of units	211
	1.1 General	
	1.2 Arrangements for oil fuel, lubricating oil and other flammable oils	
	1.3 Installation of internal combustion engines and boilers	
	1.4 Machinery controls	
	1.5 Pumping and piping systems	
	1.6 Position keeping systems and components	
	1.7 Jacking system	
	1.8 Mud system level alarms	
2	Additional requirements for machinery and electrical installations of self-propelled units	216
	2.1 General	
	2.2 Means of going astern	
	2.3 Steam boilers and boiler feed systems	
	2.4 Machinery controls	
	2.5 Steering gear	
	2.6 Electric and electrohydraulic steering gear	
	2.7 Communication between the navigating bridge and the engine-room	
	2.8 Engineer's alarm	

Section 5 Electrical Installations

1	General	220
	1.1 Application	
	1.2 Documentation to be submitted	
	1.3 Power sources location	
2	Main plant	220
	2.1 Shaft generators	
	2.2 Requirement for self propelled units	
3	Shore connection	221
	3.1 Shore supply	
4	Emergency plant	221
	4.1 Application	
	4.2 Emergency source of electrical power	
5	Electrical installations in hazardous location	224
	5.1 Monitoring of circuits in hazardous areas	
	5.2 Precautions against inlet of gases or vapours	
	5.3 Hazardous location classification and permitted electrical equipment	
	5.4 Ventilation	
	5.5 Protection in overpressure	
	5.6 Hazardous area	
	5.7 Permitted electrical equipment	

Section 6 Electric Propulsion Plant

1	General	226
	1.1	Applicable requirements
	1.2	Operating conditions
2	Design of the propulsion plant	226
	2.1	General
	2.2	Power supply
	2.3	Auxiliary machinery
	2.4	Electrical Protection
	2.5	Excitation of electric propulsion motor
3	Construction of rotating machines and semiconductor convertors	227
	3.1	Ventilation
	3.2	Protection against moisture and condensate
	3.3	Rotating machines
	3.4	Semiconductor convertors
4	Control and monitoring	228
	4.1	General
	4.2	Power plant control systems
	4.3	Indicating instruments
	4.4	Alarm system
	4.5	Reduction of power
5	Installation	229
	5.1	Ventilation of spaces
	5.2	Cable runs
6	Tests	229
	6.1	Test of rotating machines
7	Specific requirements for PODs	230
	7.1	General
	7.2	Rotating commutators
	7.3	Electric motors
	7.4	Instrumentation and associated devices
	7.5	Additional tests

Section 7 Automation

1	General	231
	1.1	Application
2	Control of propulsion machinery	231
	2.1	Remote control
	2.2	Remote control from navigating bridge
	2.3	Automatic control
	2.4	Automatic control of propulsion and manoeuvring units
	2.5	Clutches
	2.6	Brakes

Section 8 Safety Systems and Fire Protection, Detection and Extinction

1	General	233
	1.1 Purpose and application	
2	Fire and gas detection	233
	2.1 Areas to be protected	
3	Emergency shut down system	233
	3.1 Documents to be submitted	
	3.2 Emergency conditions due to drilling operations	
4	Fire protection, detection and extinction	233
	4.1 Emergency control stations	

Appendix 1 Impact Loads and Vortex Shedding

1	General	234
	1.1 Application	
	1.2 Wave slamming against horizontal members	
	1.3 Impact from breaking waves	
2	Vortex shedding	234
	2.1 General	
	2.2 Vortex shedding due to wind	
	2.3 Vortex shedding due to steady current	
	2.4 Vortex shedding due to waves	
	2.5 Vortex shedding induced forces	

Appendix 2 Fatigue Analysis with Determination of the Cumulative Damage

1	General	239
	1.1 Application	
2	Determination of long term distribution of stress range	239
	2.1	
3	Fatigue curve (S-N curve)	239
	3.1	
4	Determination of the cumulative damage	239
	4.1	

Appendix 3 An Example of Alternative Criteria for a Range of Positive Stability after Damage or Flooding for Column-stabilized Semisubmersible Units

1	General	242
	1.1 Application	

Appendix 4 An Example of Alternative Criteria Intact Stability Criteria for Twin-Pontoon Column-stabilized Semisubmersible Units

1	General	243
	1.1 Application	
2	Intact stability	243
	2.1	
3	Geometric parameters	243
	3.1	

CHAPTER 5

FLNG

Section 1 General

1	Scope	248
	1.1 Application	
2	Documentation to be submitted	249
	2.1	
3	Cargo equipment trials	249
	3.1 Scope	
	3.2 Extent of the tests	

Section 2 Stability

1	General	251
	1.1	
2	Intact stability	251
	2.1 General requirements IGC CODE REFERENCE: Ch 2, 2.2.2	
	2.2 Weather criterion IGC CODE REFERENCE : Ch 2, 2.2.2	
	2.3 Alternative stability criteria IGC CODE REFERENCE : Ch 2, 2.2.2	
3	Location of cargo tanks and process equipment	252
	3.1 Deck cargo tanks	
	3.2 Oil tanks	
	3.3 Process equipment	

Section 3 Unit Arrangement

1	Segregation of the cargo area	253
	1.1 Segregation of hold spaces	
	1.2 Cargo containment systems not requiring secondary barriers	
	1.3 Cargo containment systems requiring secondary barriers	
	1.4 Segregation of the Process Area	
2	Accommodation, service and machinery spaces and control stations	253
	2.1 General	
3	Cargo pump rooms and cargo compressor rooms	254
	3.1 Location of cargo pump rooms and cargo compressor rooms	
4	Access arrangement	254
	4.1 Access to compartments in the cargo area	

5	Air-locks	256
	5.1 Arrangement	
	5.2 Alarm	
	5.3 Electrical equipment	
	5.4 Ventilation	
6	Bilge, ballast and fuel oil arrangements	256
	6.1 Drainage arrangement	
	6.2 Additional requirements relative to the bilge system	
7	Bow or stern loading and unloading arrangements	257
	7.1 Locations of stopping devices for cargo pumps and compressors	
8	Location of cargo control rooms	257
	8.1 Location of cargo control rooms	

Section 4 Cargo Containment

1	General	258
	1.1	
2	LPG and LNG storage	258
	2.1 Symbols	
	2.2 Design pressure in harbour conditions	
	2.3 Design temperature	
3	Design loads	258
	3.1 General	
	3.2 Internal pressure for integral tanks, membrane tanks and type A independent tanks	
	3.3 Internal pressure for type B and C independent tanks	
4	Hull scantlings	260
	4.1 Plating	
	4.2 Ordinary stiffeners	
	4.3 Primary supporting members	
5	Structural analysis of integral tanks	260
	5.1 Scantlings	
6	Structural analysis of membrane tanks	261
	6.1 General	
	6.2 Scantlings	
7	Structural analysis of type A independent tanks	261
	7.1 Scantlings	
8	Structural analysis of type B independent tanks	261
	8.1 Plating and ordinary stiffeners	
	8.2 Primary supporting members	
	8.3 Fatigue analysis	
	8.4 Crack propagation analysis	
9	Structural analysis of type C independent tanks	264
	9.1 Stiffening rings in way of tank supports	

10	Supports	265
	10.1 Structural arrangement	
	10.2 Calculation of reaction forces in way of tank supports	
	10.3 Keys	
	10.4 Scantlings of type C independent tank supports and hull structures in way	
11	Secondary barrier	266
	11.1 Secondary barrier extent	
12	Insulation	266
	12.1 Heating of structures	
13	Materials	266
	13.1 Insulation material characteristics	
14	Construction and testing	266
	14.1 Integral tank testing	
	14.2 Membrane and semi-membrane tanks testing	
	14.3 Independent tank testing	
	14.4 Final tests	
15	Structural details	267
	15.1 Special structural details	
	15.2 Connections of the inner hull plating with intermediate plating	
	15.3 Connections of inner bottom with transverse cofferdam bulkheads	
	15.4 Cut-outs and connections	

Section 5 Liquefaction Process Systems, Process Pressure Vessels and Liquid, Vapour and Pressure Piping Systems

1	Liquefaction process systems	268
	1.1 General	
	1.2 Design and construction	
2	Process pressure vessels	269
	2.1	
3	Cargo and process piping	269
	3.1 General	
	3.2 Design pressure	
	3.3 Flanges	
	3.4 Stress analysis	
	3.5 Aluminised pipes	
4	Cargo system valving requirements	271
	4.1 Cargo tank connections for gauging	
	4.2 Emergency shutdown	
5	Cargo transfer methods	271
	5.1 Discharge into common header	
6	Bonding	271
	6.1 Static electricity	

7	Integrated cargo and ballast system	271
7.1	General	

Section 6 Materials for Construction

1	Material requirements	272
1.1	Tubes, forgings and castings for cargo and process piping	
1.2	Aluminium coatings	
2	Welding and non-destructive testing	272
2.1	Welding consumables	
2.2	Test requirements	

Section 7 Cargo Pressure/Temperature Control

1	Cargo Pressure/Temperature Control	273
1.1	General	
2	Additional requirements for refrigerating plants	273
2.1		
3	Reliquefaction plant of FSRU	273
3.1	Mechanical refrigeration fitted as the primary system for cargo pressure control	
3.2	Mechanical refrigeration fitted as a secondary system for cargo pressure control	
4	Cargo Compressor Systems	273
4.1	Cargo compressors	
4.2	Cargo Compressor Drives	
5	Oxidation Systems	274
5.1		
6	Venting and Flaring	274
6.1	General	

Section 8 Cargo Tank and Process Venting System

1	Pressure relief systems	275
1.1	Hydrocarbon storage tanks	
1.2	Process vessels	
1.3	Interbarrier spaces	
1.4	Vents	
1.5	Segregation of vents	
1.6	Back pressure	
2	Additional pressure relieving system for liquid level control	276
2.1	General	

Section 9 Environmental Control

1	Cargo storage tanks and piping environmental control	277
1.1	General	
2	Inerting	277
2.1	General	
3	Inert gas production on board	277
3.1	General	
3.2	Exemptions	
4	Inerting of liquefaction process vessels and piping	277
4.1	General	
4.2	Nitrogen generators	

Section 10 Electrical Installations

1	General	279
1.1	Application	
1.2	Definitions	
1.3	Monitoring of circuits in hazardous areas	
1.4	Precautions against inlet of gases or vapours	
2	Hazardous location classification and permitted electrical equipment	279
2.1	General	
2.2	Ventilation	
2.3	Hazardous area and electrical equipment	
2.4	Process plant location classification and permitted electrical equipment	
3	Sources of electrical power and distribution systems	282
3.1	Power source location	

Section 11 Safety System and Fire Protection

1	Fire and gas detection	288
1.1	General	
2	Emergency shutdown system	288
2.1	Drawings to be submitted	
2.2	General requirements and definitions	
2.3	Basic design principles	
2.4	Design and functional requirements	
2.5	Automatic and manual shutdown	
2.6	Electrical equipment for use in an emergency	
2.7	Emergency shutdown stations	
3	Fire protection, detection and extinction	290
3.1	General	
3.2	Water spray system	
3.3	Dry chemical powder fire-extinguishing system	
3.4	Cargo compressor, equipment and pump rooms	
3.5	Gas detection system	

4	Inert gas system	291
4.1	Application	
4.2	General requirements for inert gas systems	
4.3	Requirements for equivalent systems	
5	Escape routes, lifesaving and safety equipment	292
5.1	General	

Section 12 Mechanical Ventilation in the Cargo Area

1	General	293
1.1	Application	
2	Spaces required to be entered during normal cargo handling operations	293
2.1	Location of discharges from dangerous spaces	
2.2	Recirculation prevention	
3	Spaces not normally entered	293
3.1	General requirements	

Section 13 Instrumentation (Gauging, Gas Detection)

1	General	294
1.1		
1.2	Cargo tank instrumentation	
1.3	Detection of leak through secondary barrier	
1.4	Indicator location	
2	Level indicators for cargo tanks	294
2.1	General	
3	Overflow control	294
3.1	General	
3.2	Overflow alarm and shutdown	
4	Pressure gauges	295
4.1	Pressure gauges in cargo tanks	
5	Temperature indicating devices	295
5.1	General	
6	Gas detection requirements	295
6.1	General	
6.2	Position of sampling heads	
6.3	Gas sampling lines	
6.4	Protected spaces	
6.5	Portable gas detectors	

Section 14	Protection of Personnel	
1	Personnel protection requirements for individual products	296
	1.1 General	
	1.2 Showers and eye wash	
Section 15	Filling Limits for Cargo Tanks	
1	General	297
	1.1	
Section 16	Use of Cargo as Fuel	
1	Gas fuel supply	298
	1.1 Gas fuel supply to machinery spaces under decks	
	1.2 Valves on the gas fuel supply to machinery spaces under decks	
2	Gas make-up plant and related storage tanks	298
	2.1 General	
	2.2 Compressors	
	2.3 Heaters	
3	Special requirements for boilers	299
	3.1 Boiler arrangement	
	3.2 Combustion chamber	
	3.3 Burner system	
4	Special requirements for gas fired internal combustion engines and gas fired turbines	299
	4.1 Gas fuel supply to engine	
	4.2 Gas fuel supply piping systems	
	4.3 Shut-off of gas fuel supply	
	4.4 Emergency stop of dual fuel engines	
	4.5 Gas fuel make-up plant and related storage tanks	
	4.6 Requirements for gas fired internal combustion engines	
Section 17	Special Requirements	
1	General	302
	1.1 Liquefaction process	
	1.2 Offshore requirements	

CHAPTER 6

FPU

Section 1 General

1	General	306
1.1	Application	
1.2	Summary table	
1.3	Definition	

Section 2 Hull

1	General analysis and design principles	309
1.1	Methods of analysis and calculation	
1.2	Design	
2	Environmental conditions	309
2.1	General	
2.2	Acceptability of the parameters defining the design environmental conditions	
2.3	Recurrence periods and environmental conditions	
2.4	Parameters relevant to environmental phenomena	
3	Environmental conditions and design loads	313
3.1	General	
3.2	Gravity loads	
3.3	Functional Loads	
3.4	Environmental loads	
3.5	Additional loads	
4	Structural analysis	317
4.1		
5	Safety factors and permissible stresses	319
5.1		
6	Special design principles applied to surface units	319
6.1	Hull	
7	Special design principles applied to column stabilized units	319
7.1	General	
7.2	Wave clearance of upper deck	
7.3	Upper deck	
7.4	Columns, lower hulls and footings	
7.5	Bracing members	
7.6	Structural redundancy	
7.7	Fatigue analysis	

Section 3 Stability

1	General	323
	1.1 Application	
	1.2 Document to be submitted	
2	Inclining test	323
	2.1	
3	Righting moment and heeling moment curves	323
	3.1	
4	Intact stability criteria	325
	4.1	
5	Subdivision and damage stability	325
	5.1 Surface units	
	5.2 Column-stabilized units	
	5.3 All types of units	
	5.4	
6	Extent of damage	327
	6.1 Surface units	
	6.2 Column-stabilized units	
7	Watertight integrity	328
	7.1 General	
	7.2 Tank boundaries	
8	Closing appliances	328
	8.1 General requirements related to intact stability	
	8.2 General requirements related to damage stability	
9	Freeboard	329
	9.1 General	
	9.2 Surface units	
	9.3 Column-stabilized units	

Section 4 Machinery

1	Machinery installations for all types of units	331
	1.1 General	
	1.2 Arrangements for oil fuel, lubricating oil and other flammable oils	
	1.3 Installation of internal combustion engines and boilers	
	1.4 Machinery controls	
	1.5 Pumping and piping systems	
	1.6 Position keeping systems and components	

2	Additional requirements for machinery and electrical installations of self-propelled units	336
2.1	General	
2.2	Means of going astern	
2.3	Steam boilers and boiler feed systems	
2.4	Machinery controls	
2.5	Steering gear	
2.6	Electric and electrohydraulic steering gear	
2.7	Communication between the navigating bridge and the engine-room	
2.8	Engineer's alarm	

Section 5 Electrical Installations

1	General	340
1.1	Application	
1.2	Documentation to be submitted	
1.3	Power sources location	
2	Main plant	340
2.1	Shaft generators	
2.2	Requirement for self propelled units	
3	Shore connection	341
3.1	Shore supply	
4	Emergency plant	341
4.1	Application	
4.2	Emergency source of electric power	
5	Electrical installations in hazardous location	344
5.1	Monitoring of circuits in hazardous areas	
5.2	Precautions against inlet of hazardous areas	
5.3	Hazardous location classification and permitted electrical equipment	
5.4	Ventilation	
5.5	Protection in overpressure	
5.6	Process plant location classification and permitted electrical equipment	

Section 6 Electric Propulsion Plant

1	General	346
1.1	Applicable requirements	
1.2	Operating conditions	
2	Design of the propulsion plant	346
2.1	General	
2.2	Power supply	
2.3	Auxiliary machinery	
2.4	Electrical protection	
2.5	Excitation of electric propulsion motor	

3	Construction of rotating machines and semiconductor convertors	347
3.1	Ventilation	
3.2	Protection against moisture and condensate	
3.3	Rotating machines	
3.4	Semiconductor convertors	
4	Control and monitoring	348
4.1	General	
4.2	Power plant control systems	
4.3	Indicating instruments	
4.4	Alarm systems	
4.5	Reduction of power	
5	Installation	350
5.1	Ventilation of spaces	
5.2	Cable runs	
6	Tests	350
6.1	Test of rotating machines	
7	Specific requirements for PODs	350
7.1	General	
7.2	Rotating commutators	
7.3	Electric motors	
7.4	Instrumentation and associated devices	
7.5	Additional tests	

Section 7 Automation

1	General	352
1.1	Application	
2	Additional requirements for refrigerating plants	352
2.1	Remote control	
2.2	Remote control from navigating bridge	
2.3	Automatic control	
2.4	Automatic control of propulsion and manoeuvring units	
2.5	Clutches	
2.6	Brakes	

Section 8 Safety Systems

1	General	354
1.1	Purpose and application	
1.2	Documents to be submitted	
2	Fire and gas detection	354
2.1	General requirements	

3	Emergency shutdown systems	354
3.1	General requirements and definitions	
3.2	Basic design principles	
3.3	Design and functional requirements	
3.4	Automatic and manual shutdown	
3.5	Electrical equipment for use in an emergency	

Section 9 Fire Protection, Detection and Extinction

1	General	357
1.1	Application	
1.2	Documentation to be submitted	
2	Active fire protection	357
2.1	Fixed fire extinguishing systems water demand	
2.2	Protection of production area	
3	Fire and gas detection	358
3.1	Fire detection and alarm system	
3.2	Gas detection system	
4	Personnel protection	358
4.1	Firefighter's outfits	

Appendix 1 Impact Loads and Vortex Shedding

1	General	359
1.1	Application	
1.2	Wave slamming against horizontal members	
1.3	Impact from breaking waves	
2	Vortex shedding	359
2.1	General	
2.2	Vortex shedding due to wind	
2.3	Vortex shedding due to steady current	
2.4	Vortex shedding due to waves	
2.5	Vortex shedding induced forces	

Appendix 2 Fatigue Analysis with Determination of the Cumulative Damage

1	General	364
1.1	Application	
2	Determination of long term distribution of stress range	364
2.1	General	
3	Fatigue curve (S-N curve)	364
3.1		
4	Determination of the cumulative damage	364
4.1		

Appendix 3 An Example of Alternative Criteria for a Range of Positive Stability after Damage or Flooding for Column-stabilized Semisubmersible Units

1	General	367
	1.1 Application	

Appendix 4 An example of Alternative Criteria Intact Stability Criteria for Twin-Pontoon Column-stabilized Semisubmersible Units

1	General	368
	1.1 Application	
2	Intact stability	368
	2.1	
3	Geometric parameters	368
	3.1	

SECTION 1	GENERAL
SECTION 2	UNIT ARRANGEMENT
SECTION 3	HULL AND STABILITY
SECTION 4	MACHINERY AND SYSTEMS IN CARGO AREA
SECTION 5	ELECTRICAL INSTALLATIONS
SECTION 6	FIRE PROTECTION, DETECTION AND EXTINCTION
APPENDIX 1	DEVICES TO PREVENT THE PASSAGE OF FLAME INTO THE CARGO TANKS
APPENDIX 2	DESIGN OF CRUDE OIL WASHING SYSTEMS

SECTION 1

GENERAL

1 General

1.1 Application

1.1.1 Units complying with the requirements of this Chapter are eligible for the assignment of the service notation **FSO**, as defined in Pt A, Ch 1, Sec 2, [4.2.1].

1.1.2 Units dealt with in this Chapter are to comply with the requirements stipulated in Part A, Part B, Part C and Part D, as applicable and with the requirements of this Chapter, which are specific to floating units intended for the storage and off-loading of liquid hydrocarbons.

1.2 Summary table

1.2.1 Tab 1 indicates, for easy reference, the Sections of this Chapter dealing with requirements applicable to units having the notation **FSO**.

Table 1

Main subject	Reference
Ship arrangement	Sec 2
Hull and stability	Sec 3
Machinery	Sec 4
Electrical installations	Sec 5
Automation	(1)
Fire protection, detection and extinction	Sec 6
(1) No specific requirements for FSO are given in this Chapter.	

SECTION 2

UNIT ARRANGEMENT

1 General arrangement design

1.1 General

1.1.1 Cargo segregation

Unless expressly provided otherwise, tanks containing cargo or cargo residues are to be segregated from accommodation, service and machinery spaces, drinking water and stores for human consumption by means of a cofferdam of width not less than 760 mm, or any other similar compartment.

Where accommodation and service compartments are arranged immediately above the compartments containing flammable liquids, the cofferdam may be omitted only where the deck is not provided with access openings and is coated with a layer of material recognised as suitable by the Society. The cofferdam may also be omitted where such compartments are adjacent to a passageway, subject to the following conditions:

- the thicknesses of common boundary plates of adjacent tanks are increased, with respect to those obtained from the applicable requirements in Part B and Sec 3, by 2 mm in the case of tanks carrying fresh water or boiler feed water, and by 1 mm in all other cases
- the sum of the throats of the weld fillets at the edges of such plates is not less than the thickness of the plates themselves
- the hydrostatic test is carried out with a head increased by 1 m with respect to that required in Pt B, Ch 12, Sec 3 of the Rules for the Classification of Ships.

1.1.2 Deck spills

Means are to be provided to keep deck spills away from the accommodation and service areas. This may be accomplished by providing a permanent continuous coaming of a suitable height extending from side to side.

Where gutter bars are installed on the weather decks in way of cargo manifolds and are extended aft as far as the aft bulkhead of superstructures for the purpose of containing cargo spills on deck during loading and discharge operations, the free surface effects caused by containment of a cargo spill during liquid transfer operations or of boarding seas while underway are to be considered with respect to the vessel's available margin of positive initial stability (GM_0).

On units without deck camber, or where the height of the installed gutter bars exceeds the camber, and for units having cargo tanks exceeding 60% of the unit's maximum beam amidships regardless of gutter bar height, gutter bars may not be accepted without an assessment of the initial stability (GM_0) for compliance with the relevant intact stability requirements taking into account the free surface effect caused by liquids contained by the gutter bars.

2 Access arrangement

2.1 General

2.1.1 As far as practicable, permanent or movable means of access stored on board are to be provided to ensure proper survey and maintenance of cargo tanks and ballast compartments.

2.1.2 Means of access to side and centre tanks may not be provided in the same transverse section.

2.2 Access to pipe tunnel and opening arrangement

2.2.1 Access to the pipe tunnel in the double bottom

The pipe tunnel in the double bottom is to comply with the following requirements:

- it may not communicate with the engine room
- provision is to be made for at least two exits to the open deck arranged at a maximum distance from each other. One of these exits fitted with a watertight closure may lead to the cargo pump room.

2.2.2 Doors between pipe tunnel and main pump room

Where there is a permanent access from a pipe tunnel to the main pump room, a watertight door is to be fitted complying with the requirements in Pt B, Ch 2, Sec 1, [2.2.1] for watertight doors open at sea and located below the free-board deck. In addition the following is to be complied with:

- in addition to bridge operation, the watertight door is to be capable of being manually closed from outside the main pump room entrance
- the watertight door is to be kept closed during normal operations of the unit except when access to the pipe tunnel is required. A notice is to be affixed to the door to the effect that it may not be left open.

2.3 Access to compartments in the cargo area

2.3.1 General

Access to cofferdams, ballast tanks, cargo tanks and other compartments in the cargo area is to be direct from the open deck and such as to ensure their complete inspection. Access to double bottom compartments may be through a cargo pump room, pump room, deep cofferdam, pipe tunnel or similar compartments, subject to consideration of ventilation aspects.

2.3.2 Access to the fore peak tank

The access to the fore peak tank is to be direct from the open deck.

Alternatively, indirect access from the open deck to the fore peak tank through an enclosed space may be accepted provided that:

- a) if the enclosed space is separated from the cargo tanks by cofferdams, the access is through a gas-tight bolted manhole located in the enclosed space and a warning sign is provided at the manhole stating that the fore peak tank may only be opened after:
 - it has been proven to be gas-free; or
 - any electrical equipment which is not electrically certified safe in the enclosed space is isolated
- b) if the enclosed space has a common boundary with the cargo tanks and is therefore hazardous, the enclosed space can be well ventilated.

2.3.3 Access through horizontal openings

For access through horizontal openings the dimensions are to be sufficient to allow a person wearing a self-contained, air-breathing apparatus and protective equipment to ascend or descend any ladder without obstruction and also to pro-

vide a clear opening to facilitate the hoisting of an injured person from the bottom of the compartment. The minimum clear opening is to be not less than 600 mm by 600 mm.

2.3.4 Access through vertical openings

For access through vertical openings the minimum clear opening is to be not less than 600 mm by 800 mm at a height of not more than 600 mm from the bottom shell plating unless gratings or other footholds are provided.

2.4 Access to the bow

2.4.1 FSO units are to be provided either with a gangway between the superstructure or deckhouse aft and the fore-castle, or with equivalent arrangements in accordance with the International Load Line Convention 1966, as amended.

2.4.2 FSO units are to be provided with the means to enable the crew to gain safe access to the bow even in severe weather conditions. Such means are to be accepted by the Society.

Note 1: The Society considers means in compliance with the Guidelines adopted by the Maritime Safety Committee of IMO with Resolution MSC.62(67) on 5/12/1996 as being acceptable.

SECTION 3 HULL AND STABILITY

Symbols

- R_y : Minimum yield stress, in N/mm², of the material, to be taken equal to 235/k N/mm², unless otherwise specified
- k : Material factor for steel, defined in Pt B, Ch 4, Sec 1, [2.3] of the Rules for the Classification of Ships
- E : Young's modulus, in N/mm², to be taken equal to:
- $E = 2,06 \cdot 10^5$ N/mm² for steels in general
 - $E = 1,95 \cdot 10^5$ N/mm² for stainless steels.

1 General

1.1

1.1.1 This Section applies in addition to the requirements set out in Part B.

2 Intact stability

2.1 General requirements

2.1.1 In each loading condition the following is to be satisfied:

- a) the initial metacentric height, calculated by taking into account the influence of the free surfaces, is to be not less than 0,15 m
- b) the diagrams of the stability arms are to confirm the following requisites:
 - 1) the arm of maximum stability Gz_{max} is to correspond to a transverse heeling angle preferably greater than 30° but in any case not less than 25°;
 - 2) the arm of stability GZ is to be not less than 0,20 m with a transverse heeling angle θ not less than 30°;
 - 3) the area below the stability diagram is to be not less than 0,055 m·rad for heeling angles θ from 0° to 30° and not less than 0,09 m·rad for heeling angles θ from 0° to 40° or to θ_i if the latter is less than 40°.

The heeling angle θ_i is that which corresponds to the intake of water and therefore defines where the stability curve is to be considered broken.

In addition to the above, the area below the stability diagram is to be not less than 0,030 m·rad, for heeling angles from 30° to 40° or from 30° to θ_i , if θ_i is less than 40°

- c) the provisions of the following paragraphs are to be checked in relation to the action of the wind.

2.2 Liquid transfer operation

2.2.1 Units with certain internal subdivision may be subjected to lolling during liquid transfer operations such as loading, unloading or ballasting. In order to prevent the effect of lolling, the unit's design is to be such that the following criteria are complied with:

- a) the intact stability criteria reported in b) is to be complied with for the worst possible condition of loading and ballasting as defined in c), consistent with good operational practice, including the intermediate stages of liquid transfer operations. Under all conditions the ballast tanks are to be assumed slack;
- b) the initial metacentric height GMo , in m, corrected for free surface measured at 0°heel, is to be not less than 0,15. For the purpose of calculating GMo , liquid surface corrections are to be based on the appropriate upright free surface inertia moment;
- c) the unit is to be loaded with:
 - all cargo tanks filled to a level corresponding to the maximum combined total of vertical moment of volume plus free surface inertia moment at 0°heel, for each individual tank
 - cargo density corresponding to the available cargo deadweight at the displacement at which transverse KM reaches a minimum value
 - full consumable
 - 1% of the total water ballast capacity. The maximum free surface moment is to be assumed in all ballast tanks.

2.3 Weather criterion

2.3.1 The curves are to be traced of the righting and heeling moments due to the transverse wind similar to those shown in Fig 1, together with the relevant calculations, taking into account the maximum cargo on the deck and the equipment placed in the most unfavourable position.

The effect of the free surfaces in the tanks is to be taken into account.

2.3.2 If there are structural fittings which can be dismantled and stowed, further curves of the heeling moment due to the wind may be requested and the relevant documentation is to clearly indicate the position of these fittings.

2.3.3 When calculating the righting moment, any possible negative effects due to the presence of the mooring system are to be taken into account.

2.3.4 As regards the calculation of the forces and heeling moment due to the wind, reference is made to the relevant provisions of Ch 4, Sec 3, [3.1].

In particular, for the wind speed, the characteristic value of the site corresponding to a recurring period of 100 years or the speed of 51,5 m/s (100 knots) is to be assumed, whichever is the greater.

For sites situated in protected zones, the Society reserves the right to accept a wind speed less than 51,5 m/s.

2.3.5 The stability of a unit is to satisfy the criteria stated under the following items (a) and (b) (see also Fig 1):

- a) The ratio of the area under the righting moment curve to that under the heeling moment curve up to the angle in way of the second intercept or up to the downflooding angle θ_f , whichever is the lesser, is to be not less than 1,4.
- b) The righting moment curve is to be positive over the entire range of angles up to the angle in way of the second intercept.

2.3.6 Each unit should be capable of attaining a severe storm condition in a period of time consistent with the meteorological conditions. The procedures recommended and the approximate length of time required, considering both operating conditions and transit conditions, should be contained in the Operating Manual.

It should be possible to achieve the severe storm condition without the removal or relocation of solid consumables or other variable load. However, the Society may permit loading a unit past the point at which solid consumables would have to be removed or relocated to attain the severe storm condition under the following conditions, provided the allowable KG requirement is not exceeded:

- a) in a geographic location where weather conditions annually or seasonally do not become sufficiently severe to require a unit to go to severe storm conditions, or
- b) where a unit is required to support extra deckload for a short period of time that falls well within a period for which the weather forecast is favourable.

The geographic locations, weather conditions and loading conditions in which this is permitted should be identified in the Operating Manual.

2.4 Alternative stability criteria

2.4.1 Alternative stability criteria may be considered by the Society provided an equivalent level of safety is maintained and it is demonstrated that they afford adequate positive initial stability.

3 Closing appliances

3.1 General requirements

3.1.1 Closing appliances are to comply with the applicable requirements of the International Convention on Load Line in force.

4 Watertight integrity

4.1

4.1.1 The number of openings in the watertight bulkheads is to be kept to a minimum compatible with the design and proper working of the unit.

4.1.2 Where it is necessary to penetrate the watertight bulkheads for access or piping, ventilation, electrical cables etc., arrangements are to be made to maintain the watertight integrity of the enclosed compartments.

4.1.3 When the watertight boundaries are provided with valves to maintain watertight integrity, it is to be possible to operate these valves from a pump room or other normally manned space, an open deck or a deck situated above the bulkhead deck.

4.1.4 Valve position indicators are to be provided in the remote control room.

5 Freeboard

5.1

5.1.1 Classification of the unit presupposes that all the applicable requirements and provisions contained in the International Convention on Load Line in force are complied with.

Figure 1 : Righting moment and heeling moment curves

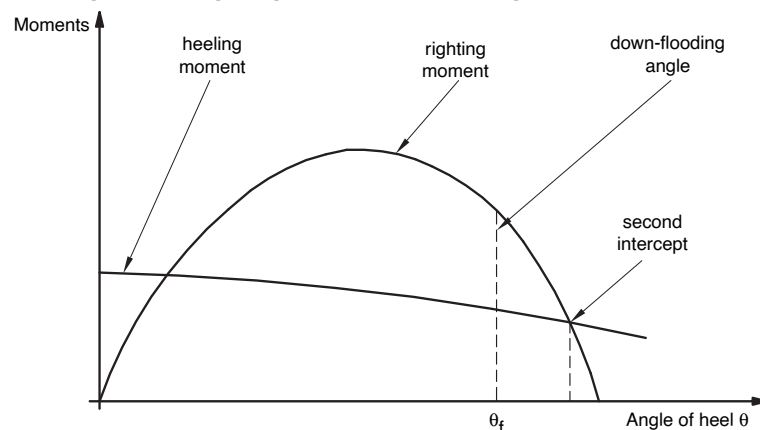

6 Structure design principles

6.1 Framing arrangement

6.1.1 In general, within the cargo tank region, the bottom, the inner bottom and the deck are to be longitudinally framed.

Different framing arrangements are to be considered by the Society on a case-by-case basis, provided that they are supported by direct calculations.

6.2 Bulkhead structural arrangement

6.2.1 General

Transverse bulkheads may be either plane or corrugated.

6.2.2 Corrugated bulkheads

For units of less than 120 m in length, vertically corrugated transverse or longitudinal bulkheads may be connected to the double bottom and deck plating.

For units equal to or greater than 120 m in length, a lower and an upper stool are generally to be fitted. Different arrangements may be considered by the Society on a case-by-case basis, provided that they are supported by direct calculations carried out according to Pt B, Ch 7, Sec 3 of the Rules for the Classification of Ships. These calculations are to investigate, in particular, the zones of connection of the bulkhead with inner bottom and deck plating and are to be submitted to the Society for review.

7 Design loads

7.1 Hull girder loads

7.1.1 Still water loads

In addition to the requirements in Pt B, Ch 5, Sec 2, [2.1.2], still water loads are to be calculated for the following loading conditions, subdivided on-site operations and transit conditions and, where applicable, into departure and arrival conditions as appropriate:

- homogeneous loading conditions (excluding tanks intended exclusively for segregated ballast tanks) at maximum draft
- partial loading conditions
- any specified non-homogeneous loading condition
- light and heavy ballast conditions
- conditions relating to tank cleaning or other operations where, at the Society's discretion, these differ significantly from the ballast conditions.

7.2 Local loads

7.2.1 Cargo mass density

In the absence of more precise values, a cargo mass density of 0,9 t/m³ is to be considered for calculating the internal pressures and forces in cargo tanks according to Pt B, Ch 5, Sec 6.

8 Hull scantlings

8.1 Plating

8.1.1 Minimum net thicknesses

The net thickness of the strength deck and bulkhead plating within or bounding the longitudinal extension of the cargo area is to be not less than the values given in Tab 1.

8.2 Ordinary stiffeners

8.2.1 Minimum net thicknesses

The net thickness of the web of ordinary stiffeners is to be not less than the value obtained, in mm, from the following formulae:

$$t_{\text{MIN}} = 0,75 L^{1/3} k^{1/6} + 4,5 s \quad \text{for } L < 275 \text{ m}$$

$$t_{\text{MIN}} = 1,5 k^{1/2} + 7,0 + s \quad \text{for } L \geq 275 \text{ m}$$

where s is the spacing, in m, of ordinary stiffeners.

8.3 Primary supporting members

8.3.1 Minimum net thicknesses

The net thickness of plating which forms the webs of primary supporting members is to be not less than the value obtained, in mm, from the following formula:

$$t_{\text{MIN}} = 1,45 L^{1/3} k^{1/6}$$

8.3.2 Loading conditions for the analyses of primary supporting members

The still water and wave loads are to be calculated for the most severe loading conditions as given in the loading manual, with a view to maximising the stresses in the longitudinal structure and primary supporting members.

Where the loading manual is not available, the loading conditions to be considered in the analysis of primary supporting members in cargo and ballast tanks are those shown in:

- Fig 1 for units less than 200 m in length
- Fig 2 and Fig 3 for units equal to or greater than 200 m in length.

Table 1 : Minimum net thickness of the strength deck and bulkhead plating

Plating	Minimum net thickness, in mm	
Strength deck	$(5,5 + 0,02 L) k^{1/2}$	for L < 200
	$(8 + 0,0085 L) k^{1/2}$	for L ≥ 200
Tank bulkhead	$L^{1/3} k^{1/6} + 4,5 s$	for L < 275
	$1,5 k^{1/2} + 8,2 + s$	for L ≥ 275
Watertight bulkhead	$0,85 L^{1/3} k^{1/6} + 4,5 s$	for L < 275
	$1,5 k^{1/2} + 7,5 + s$	for L ≥ 275
Wash bulkhead	$0,8 + 0,013 L k^{1/2} + 4,5 s$	for L < 275
	$3,0 k^{1/2} + 4,5 + s$	for L ≥ 275

Note 1:

s : Length, in m, of the shorter side of the plate panel.

Figure 2 : Loading conditions for units less than 200 m in length

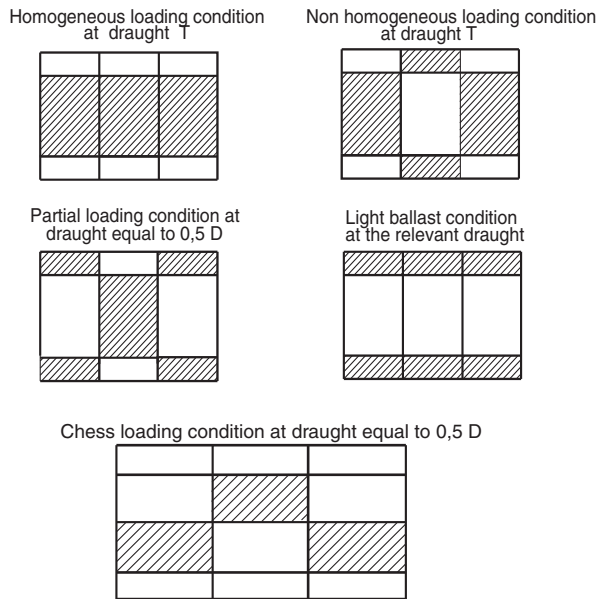

8.3.3 Strength check of floors of cargo tank structure with hopper tank analysed through a three dimensional beam model

Where the cargo tank structure with hopper tank is analysed through a three dimensional beam model, to be carried out according to Pt B, Ch 7, App 1 of the Rules for the Classification of Ships, the net shear sectional area of floors within $0,1 \ell$ from the floor ends (see Fig 4 for the definition of ℓ) is to be not less than the value obtained, in cm^2 , from the following formula:

$$A_{sh} = 2 \frac{Q}{\gamma_R \gamma_m R_y}$$

where:

- Q : Shear force, in kN, in the floors at the ends of ℓ , obtained from the structural analysis
- γ_R : Resistance partial safety factor:
 $\gamma_R = 1,2$
- γ_m : Material partial safety factor:
 $\gamma_m = 1,02$

Figure 3 : Loading conditions for units equal to or greater than 200 m in length

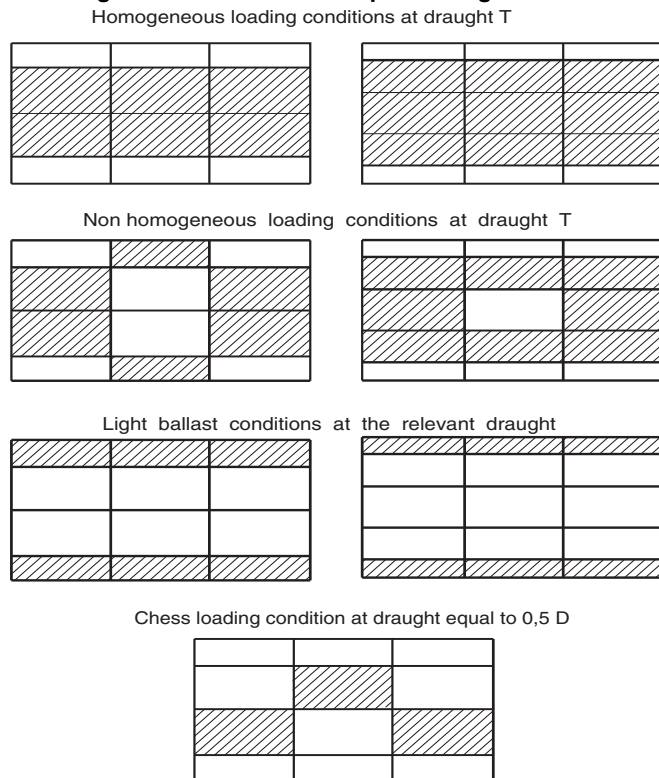
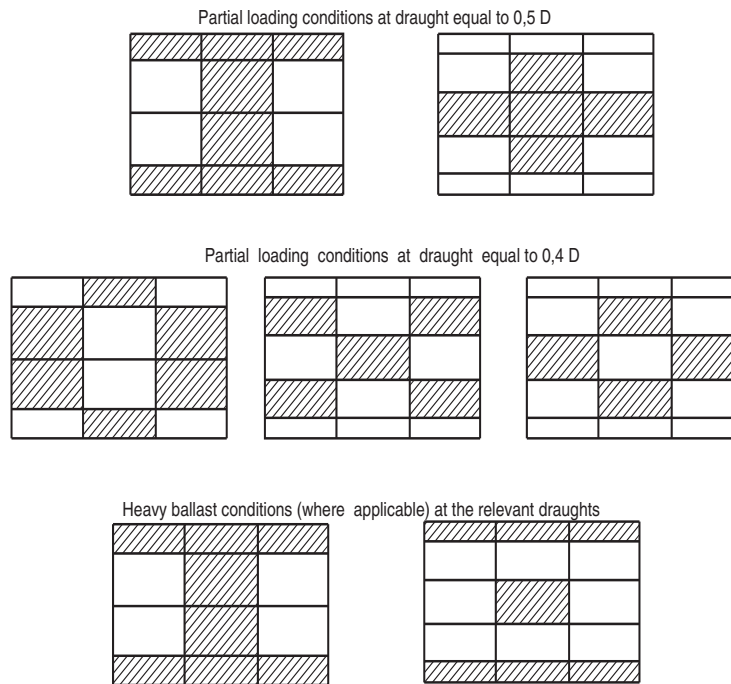

Figure 4 : Loading conditions for units equal to or greater than 200 m in length



8.3.4 Strength checks of cross-ties analysed through a three dimensional beam model

a) Cross-ties analysed through three dimensional beam model analyses according to Pt B, Ch 7, Sec 3 of the Rules for the Classification of Ships are to be considered, in the most general case, as being subjected to axial forces and bending moments around the neutral axis perpendicular to the cross-tie web. This axis is identified as the y axis, while the x axis is that in the web plane (see Figures in Tab 2).

The axial force may be either tensile or compression. Depending on this, two types of checks are to be carried out, according to b) or c), respectively.

b) Strength check of cross-ties subjected to axial tensile forces and bending moments.

The net scantlings of cross-ties are to comply with the following formula:

$$10 \frac{F_T}{A_{ct}} + 10^3 \frac{M}{w_{yy}} \leq \frac{R_y}{\gamma_R \gamma_m}$$

where:

- F_T : Axial tensile force, in kN, in the cross-ties, obtained from the structural analysis
- A_{ct} : Net sectional area, in cm^2 , of the cross-tie
- M : Max ($|M_1|$, $|M_2|$)
- M_1, M_2 : Algebraic bending moments, in kN.m, around the y axis at the ends of the cross-tie, obtained from the structural analysis
- w_{yy} : Net section modulus, in cm^3 , of the cross-tie about the y axis
- γ_R : Resistance partial safety factor:
 $\gamma_R = 1,02$

γ_m : Material partial safety factor:
 $\gamma_m = 1,02$

c) Strength check of cross-ties subjected to axial compressive forces and bending moments.

The net scantlings of cross-ties are to comply with the following formulae:

$$10 F_C \left(\frac{1}{A_{ct}} + \frac{\Phi e}{w_{xx}} \right) \leq \frac{R_y}{\gamma_R \gamma_m}$$

$$10 \frac{F_C}{A_{ct}} + 10^3 \frac{M_{max}}{w_{yy}} \leq \frac{R_y}{\gamma_R \gamma_m}$$

where:

- F_C : Axial compressive force, in kN, in the cross-ties, obtained from the structural analysis
- A_{ct} : Net cross-sectional area, in cm^2 , of the cross-tie

$$\Phi = \frac{1}{1 - \frac{F_C}{F_{EX}}}$$

F_{EX} : Euler load, in kN, for buckling around the x axis:

$$F_{EX} = \frac{\pi^2 E I_{xx}}{10^5 \ell^2}$$

- I_{xx} : Net moment of inertia, in cm^4 , of the cross-tie about the x axis
- ℓ : Span, in m, of the cross-tie
- e : Distance, in cm, from the centre of gravity to the web of the cross-tie, specified in Tab 2 for various types of profiles
- w_{ww} : Net section modulus, in cm^3 , of the cross-tie about the x axis

M_{\max} : Max ($|M_0|$, $|M_1|$, $|M_2|$)

$$M_0 = \frac{\sqrt{1+t^2}(M_1 + M_2)}{2 \cos(u)}$$

$$t = \frac{1}{\tan(u)} \left(\frac{M_2 - M_1}{M_2 + M_1} \right)$$

$$u = \frac{\pi}{2} \sqrt{\frac{F_C}{F_{EY}}}$$

F_{EY} : Euler load, in kN, for buckling around the y axis:

$$F_{EY} = \frac{\pi^2 EI_{yy}}{10^5 \ell^2}$$

I_{yy} : Net moment of inertia, in cm^4 , of the cross-tie about the y axis

M_1, M_2 : Algebraic bending moments, in kN.m, around the y axis at the ends of the cross-tie, obtained from the structural analysis

W_{yy} : Net section modulus, in cm^3 , of the cross-tie about the y axis

γ_R : Resistance partial safety factor:

$$\gamma_R = 1,02$$

γ_m : Material partial safety factor:

$$\gamma_m = 1,02$$

Figure 5 : End area of floors

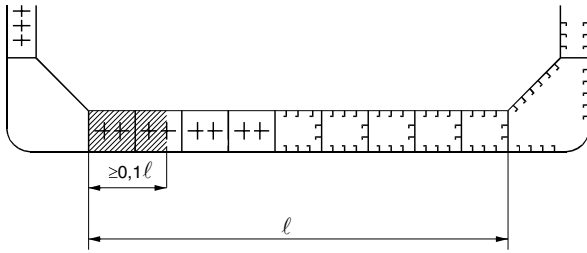

8.3.5 Strength checks of cross-ties analysed through a three dimensional finite element model

- a) In addition to the requirements in Pt B, Ch 7, Sec 3, [4] and Pt B, Ch 7, Sec 3, [6] of the Rules for the Classification of Ships, the net scantlings of cross-ties subjected to compression axial stresses are to comply with the following formula:

$$|\sigma| \leq \frac{\sigma_c}{\gamma_R \gamma_m}$$

where:

σ : Compressive stress, in N/mm^2 , obtained from a three dimensional finite element analysis, based on fine mesh modelling, according to Pt B, Ch 7, Sec 3 and Pt B, Ch 7, App 1 of the Rules for the Classification of Ships

σ_c : Critical stress, in N/mm^2 , defined in b)

γ_R : Resistance partial safety factor:

$$\gamma_R = 1,02$$

γ_m : Material partial safety factor:

$$\gamma_m = 1,02$$

- b) The critical buckling stress of cross-ties is to be obtained, in N/mm^2 , from the following formulae:

$$\sigma_c = \sigma_E \quad \text{for } \sigma_E \leq \frac{R_y}{2}$$

$$\sigma_c = R_y \left(1 - \frac{R_y}{4\sigma_E} \right) \quad \text{for } \sigma_E > \frac{R_y}{2}$$

where:

$$\sigma_E = \min(\sigma_{E1}, \sigma_{E2}),$$

σ_{E1} : Euler flexural buckling stress, to be obtained, in N/mm^2 , from the following formula:

$$\sigma_{E1} = \frac{\pi^2 EI}{10^4 A_{ct} \ell^2}$$

I : Min (I_{xx} , I_{yy})

I_{xx} : Net moment of inertia, in cm^4 , of the cross-tie about the x axis defined in [8.3.4] a)

I_{yy} : Net moment of inertia, in cm^4 , of the cross-tie about the y axis defined in [8.3.4] a)

A_{ct} : Net cross-sectional area, in cm^2 , of the cross-tie

ℓ : Span, in m, of the cross-tie

σ_{E2} : Euler torsional buckling stress, to be obtained, in N/mm^2 , from the following formula:

$$\sigma_{E2} = \frac{\pi^2 EI_w}{10^4 I_o \ell^2} + 0,41 E \frac{J}{I_o}$$

I_w : Net sectorial moment of inertia, in cm^4 , of the cross-tie, specified in Tab 2 for various types of profiles

I_o : Net polar moment of inertia, in cm^4 , of the cross-tie

$$I_o = I_{xx} + I_{yy} + A_{ct}(y_o + e)^2$$

y_o : Distance, in cm, from the centre of torsion to the web of the cross-tie, specified in Tab 2 for various types of profiles

e : Distance, in cm, from the centre of gravity to the web of the cross-tie, specified in Tab 2 for various types of profiles,

J : St. Venant's net moment of inertia, in cm^4 , of the cross-tie, specified in Tab 2 for various types of profiles.

8.4 Strength check with respect to stresses due to the temperature gradient

8.4.1 Direct calculations of stresses induced in the hull structures by the temperature gradient are to be performed for units intended to carry cargoes at temperatures exceeding 75°C . In these calculations, the water temperature is to be assumed equal to 0°C .

The calculations are to be submitted to the Society for review.

8.4.2 The stresses induced in the hull structures by the temperature gradient are to comply with the checking crite-

ria in Pt B, Ch 7, Sec 3, [4.3] of the Rules for the Classification of Ships.

Aluminium is not permitted for the construction of tank covers. The use of reinforced fibreglass covers is to be specially examined by the Society.

9 Other structures

9.1 Opening arrangement

9.1.1 Tanks covers

Covers fitted on all cargo tank openings are to be of sturdy construction, and to ensure tightness for hydrocarbon and water.

Table 2 : Calculation of cross-tie geometric properties

Cross-tie profile	e	y_0	J	I_w
<p>T symmetrical</p>	0	0	$\frac{1}{3}(2b_f t_f^3 + h_w t_w^3)$	$\frac{t_f h_w^2 b_f^3}{24}$

Cross-tie profile	e	y ₀	J	I _w
<p>T non-symmetrical</p>	0	0	$\frac{1}{3} (b_{1f} + b_{2f})t_f^3 + h_w t_w^3 $	$\frac{t_f h_w^3 b_{1f}^3 b_{2f}^3}{12 (b_{1f}^3 + b_{2f}^3)}$
<p>Non-symmetrical</p>	$\frac{b^2 t_f}{h t_w + 2 b t_f}$	$\frac{3 b^2 t_f}{6 b t_f + h_w t_w}$	$\frac{1}{3} (2 b t_f^3 + h_w t_w^3)$	$\frac{t_f b^3 h^2 3 b t_f + 2 h_w t_w}{12 6 b t_f + h_w t_w}$

10 Construction and testing

10.1 Welding and weld connections

10.1.1 The welding factors for some hull structural connections are specified in Tab 3. These welding factors are to

be used, in lieu of the corresponding factors specified in Pt B, Ch 13, Sec 1, Tab 2, to calculate the throat thickness of fillet weld T connections according to Pt B, Ch 13, Sec 1, [2.3]. For the connections of Tab 3, continuous fillet welding is to be adopted.

Table 3 : Welding factor w_F

Hull area	Connection		Welding factor w _F
	of	to	
Double bottom in way of cargo tanks	girders	bottom and inner bottom plating	0,35
		floors (interrupted girders)	0,35
	floors	bottom and inner bottom plating	0,35
		inner bottom in way of bulkheads or their lower stools girders (interrupted floors)	0,45 0,35
Bulkheads (1)	ordinary stiffeners	bulkhead plating	0,35

(1) Not required to be applied to units with the additional service feature **flashpoint > 60°C**.

SECTION 4**MACHINERY AND SYSTEMS IN CARGO AREA****1 General****1.1 Application**

1.1.1 The requirements of this section apply to the venting system, purging and/or gas-freeing system, level gauging system, protection against overload system, washing system and heating system of cargo tanks as well as to bilge and ballast systems, to air, sounding pipes and scuppers in cargo

area. The requirements for cargo handling systems are in Part C, Chapter 5.

1.2 Documentation to be submitted

1.2.1 Tab 1 lists the plans, information, analysis, etc. which are to be submitted in addition to the information required in the other Parts of the Rules.

1.2.2 The information listed in Tab 2 is also to be submitted.

Table 1 : Documents to be submitted

No	(1)	Documents (2)
1	A	Diagram of the oil cargo tank venting system with: <ul style="list-style-type: none"> • indication of the outlet position • details of the pressure/vacuum valves and flame arrestors • details of the draining arrangements, if any
2	A	Diagram of the oil cargo tank level gauging system with overfill safety arrangements
3	A	Diagram of the oil cargo tank heating system
4	A	Oil cargo tank cleaning system
5	A	Gas freeing system of cargo tanks
6	A	Diagram of bilge system in cargo area
7	A	Diagram of ballast system in cargo area
8	A	Diagram of air, sounding and scuppers in cargo area
(1) A = to be submitted for approval in four copies		
(2) Diagrams are also to include, where applicable, the (local and remote) control and monitoring systems and automation systems		

Table 2 : Informations to be submitted

No	(1)	Documents
1	A	Material, external diameter and wall thickness of the pipes
2	A	Type of the connections between pipe lengths, including details of the weldings, where provided
3	A	Material, type and size of the accessories
4	A	For plastic pipes: <ul style="list-style-type: none"> • the chemical composition • the physical and mechanical characteristics in function of temperature • the characteristics of inflammability and fire resistance • the resistance to the products intended to be conveyed
(1) A = to be submitted for approval in four copies		

2 Cargo tank venting systems

2.1 Principle

2.1.1 Cargo tanks are to be provided with venting systems entirely distinct from the air pipes of the other compartments of the unit. The arrangements and position of openings in the cargo tank deck from which emission of flammable vapours can occur are to be such as to minimise the possibility of flammable vapours being admitted to enclosed spaces containing a source of ignition, or collecting in the vicinity of deck machinery and equipment which may constitute an ignition hazard.

2.1.2 Design of venting arrangements

The venting arrangements are to be so designed and operated as to ensure that neither pressure nor vacuum in cargo tanks exceeds design parameters and be such as to provide for:

- the flow of the small volumes of vapour, air or inert gas mixtures caused by thermal variations in an cargo tank in all cases through pressure/vacuum valves, and
- the passage of large volumes of vapour, air or inert gas mixtures during oil loading and ballasting, or during discharging,
- a secondary means of allowing full flow relief of vapour, air or inert gas mixtures to prevent overpressure or under pressure in the event of failure of the arrangements in b).

Alternatively, pressure sensors may be fitted in each tank protected by the arrangement required in b), with a monitoring system in the unit's oil handling control room or the position from which oil handling operations are normally carried out. Such monitoring equipment is also to provide an alarm facility which is activated by detection of overpressure or under pressure conditions within a tank.

2.1.3 Combination of venting arrangements

- The venting arrangements in each cargo tank may be independent or combined with other cargo tanks and may be incorporated into the inert gas piping.
- Where the arrangements are combined with other cargo tanks, either stop valves or other acceptable means are to be provided to isolate each cargo tank. Where stop valves are fitted, they are to be provided with locking arrangements which are to be under the control of the responsible unit's officer. There is to be a clear visual indication of the operational status of the valves or other acceptable means. Where tanks have been isolated, it is to be ensured that relevant isolating valves are opened before oil loading or ballasting or discharging of those tanks is commenced. Any isolation must continue to permit the flow caused by thermal variations in an cargo tank in accordance with [2.1.2] a).
- If oil loading and ballasting or discharging of an cargo tank or cargo tank group is intended, which is isolated from a common venting system, that cargo tank or cargo tank group is to be fitted with a means for overpressure or under pressure protection as required in [2.1.2] c).

2.1.4 Arrangement of vent lines

The venting arrangements are to be connected to the top of each cargo tank and are to be self-draining to the cargo tanks under all normal conditions of trim and list of the unit.

Where it may not be possible to provide self-draining lines, permanent arrangements are to be provided to drain the vent lines to an cargo tank.

Plugs or equivalent means are to be provided on the lines after the safety relief valves.

2.1.5 Openings for pressure release

Openings for pressure release required by [2.1.2] a) are to:

- have as great a height as is practicable above the cargo tank deck to obtain maximum dispersal of flammable vapours but in no case less than 2 m above the cargo tank deck,
- be arranged at the furthest distance practicable but not less than 5 m from the nearest air intakes and openings to enclosed spaces containing a source of ignition and from deck machinery and equipment which may constitute an ignition hazard. Anchor windlass and chain locker openings constitute an ignition hazard.

2.1.6 Pressure/vacuum valves

- One or more pressure/vacuum-breaking devices are to be provided to prevent the cargo tanks from being subject to:
 - a positive pressure, in excess of the test pressure of the cargo tank, if the oil were to be loaded at the maximum rated capacity and all other outlets were left shut; and
 - a negative pressure in excess of 700 mm water gauge if oil were to be discharged at the maximum rated capacity of the oil pumps and the inert gas blowers were to fail.

Such devices are to be installed on the inert gas main unless they are installed in the venting system required by [2] or on individual cargo tanks.
- Pressure/vacuum valves are to be set at a positive pressure not exceeding 0,021 MPa and at a negative pressure not exceeding 0,007 MPa. Higher setting values not exceeding 0,07 MPa may be accepted in positive pressure if the scantlings of the tanks are appropriate.
- Pressure/vacuum valves required by [2.1.2] a) may be provided with a bypass when they are located in a vent main or masthead riser. Where such an arrangement is provided, there are to be suitable indicators to show whether the bypass is open or closed.
- Pressure/vacuum valves are to be of a type approved by the Society in accordance with App 1.
- Pressure/vacuum valves are to be readily accessible.
- Pressure/vacuum valves are to be provided with a manual opening device so that valves can be locked on open position. Locking means on closed position are not permitted.

2.1.7 Vent outlets

Vent outlets for cargo loading, discharging and ballasting required by [2.1.2] b) are to:

- a) permit:
- 1) the free flow of vapour mixtures, or
 - 2) the throttling of the discharge of the vapour mixtures to achieve a velocity of not less than 30 m/s,
- b) Pressure/vacuum valves are to be set at a positive pressure not exceeding 0,021 MPa and at a negative pressure not exceeding 0,007 MPa. Higher setting values not exceeding 0,07 MPa may be accepted in positive pressure if the scantlings of the tanks are appropriate.
- c) where the method is by free flow of vapour mixtures, be such that the outlet is not less than 6 m above the cargo tank deck or fore and aft gangway if situated within 4 m of the gangway and located not less than 10 m measured horizontally from the nearest air intakes and openings to enclosed spaces containing a source of ignition and from deck machinery which may include anchor windlass and chain locker openings, and equipment which may constitute an ignition hazard,
- d) where the method is by high velocity discharge, be located at a height not less than 2 m above the cargo tank deck and not less than 10 m measured horizontally from the nearest air intakes and openings to enclosed spaces containing a source of ignition and from deck machinery which may include anchor windlass and chain locker openings, and equipment which may constitute an ignition hazard. These outlets are to be provided with high velocity devices of a type approved by the Society,
- e) be designed on the basis of the maximum designed loading rate multiplied by a factor of at least 1,25 to take account of gas evolution, in order to prevent the pressure in any oil tank from exceeding the design pressure.
- The Master is to be provided with information regarding the maximum permissible loading rate for each cargo tank and in the case of combined venting systems, for each group of cargo tanks,
- f) the arrangements for the venting of vapours displaced from the cargo tanks during loading and ballasting are to comply with [2] and are to consist of either one or more mast risers, or a number of high-velocity vents. The inert gas supply main may be used for such venting.

2.1.8 High velocity valves

- a) High velocity valves are to be readily accessible.
- b) High velocity valves not required to be fitted with flame arresters (see [2.1.9]) are not to be capable of being locked on open position.

2.1.9 Prevention of the passage of flame into the tanks

- a) The venting system is to be provided with devices to prevent the passage of flame into the cargo tanks. The design, testing and locating of these devices are to comply with App 1.
Ullage openings are not to be used for pressure equalisation.
They are to be provided with self-closing and tightly sealing covers. Flame arresters and screens are not permitted in these openings.
- b) A flame arresting device integral to the venting system may be accepted.
- c) Flame screens and flame arresters are to be designed for easy overhauling and cleaning.

2.1.10 Prevention of liquid rising in the venting system

- a) Provisions are to be made to prevent liquid rising in the venting system; refer to [5]
- b) Cargo tanks gas venting systems are not to be used for overflow purposes.
- c) Spill valves are not considered equivalent to an overflow system.

3 Cargo tank purging and/or gas-freeing

3.1 General

3.1.1 Arrangements are to be made for purging and/or gas freeing of cargo tanks. The arrangements are to be such as to minimise the hazards due to the dispersal of flammable vapours in the atmosphere and to flammable mixtures in a cargo tank.

In the case of fans installed in safe spaces, two non return devices are to be fitted to avoid return of oil vapours to safe spaces when the ventilation system is shut down. These non-return devices are to operate in all normal conditions of unit trim and list.

Discharge outlets are to be located at least 10 m measured horizontally from the nearest air intake and openings to enclosed spaces with a source of ignition and from deck machinery equipment which may constitute an ignition hazard.

The cargo tanks are first to be purged in accordance with the provisions of Sec 6, [8] until the concentration of hydrocarbon vapours in the oil tanks has been reduced to less than 2% by volume. Thereafter, gas-freeing may take place at the cargo tank deck level.

4 Cargo tank level gauging systems

4.1 General

4.1.1 Each cargo or slop tank is to be fitted with a level gauging system indicating the liquid level along the entire height of the tank.

Gauging devices and their remote reading systems are to be type approved.

The gauging devices are to be of the closed type.

A "closed type gauging device" means a device which is separated from the tank atmosphere and keeps tank contents from being released. It may:

- penetrate the tank, such as float-type systems, electric probe, magnetic probe or protected sight glass,
- not penetrate the tank, such as ultrasonic or radar devices.

Use of indirect gauging devices will be given special consideration.

An "indirect gauging device" means a device which determines the level of liquid, for instance by means of weighing or pipe flow meter .

5 Protection against tank overload

5.1 General

5.1.1 The following requirements are to be complied with:

- a) Provisions are to be made to guard against liquid rising in the venting system of cargo or slop tanks to a height which would exceed the design head of the tanks. This is to be accomplished by high level alarms or overflow control systems or other equivalent means, together with gauging devices and cargo tank filling procedures.
- b) Sufficient ullage is to be left at the end of tank filling to permit free expansion of liquid during carriage.
- c) High level alarms, overflow control systems and other means referred to in a) are to be independent of the gauging systems referred to in [4].

5.1.2 High level alarms

- a) High level alarms are to be type approved.
- b) High level alarms are to give an audible and visual signal at the control station, where provided.

5.1.3 Other protection systems

- a) Where the tank level gauging systems, oil and ballast pump control systems and valve control systems are centralised in a single location, the provisions of [5.1.1] may be complied with by the fitting of a level gauge for the indication of the end of loading, in addition to that required for each tank in [4]. The readings of both gauges for each tank are to be as near as possible to each other and so arranged that any discrepancy between them can be easily detected.
- b) Where a tank can be filled only from other tanks, the provisions of [5.1.1] are considered as complied with.

6 Tank washing systems

6.1 General

6.1.1 Adequate means are to be provided for cleaning the cargo tanks.

Crude oil washing systems are to comply with the provisions of App 2 which are related to safety only.

6.1.2 Washing machines

Washing machines are to be made of steel or other electricity conducting materials with a limited propensity to produce sparks on contact.

6.1.3 Washing pipes

- a) Washing pipes are to be built, fitted, inspected and tested in accordance with the applicable requirements of Pt C, Ch 1, Sec 10 of the Rules for the Classification of Ships, depending on the kind of washing fluid, water or crude oil.
- b) Crude oil washing pipes are also to satisfy the requirements of Pt C, Ch 5, Sec 2.

6.1.4 Use of crude oil washing machines for water washing operations

Crude oil washing machines may be connected to water washing pipes, provided that isolating arrangements, such as a valve and a detachable pipe section, are fitted to isolate water pipes.

6.1.5 Installation of washing systems

- a) Tank cleaning openings are not to be arranged in enclosed spaces.
- b) The complete installation is to be permanently earthed to the hull.

7 Heating systems intended for cargo tanks and other users in cargo area

7.1 General

7.1.1 The following general requirements apply:

- a) Heating systems intended for cargo are to comply with the relevant requirements of Pt C, Ch 1, Sec 10 of the Rules for the Classification of Ships.
- b) The steam and heating media temperature within the cargo area is not to exceed 220° C.
- c) Blind flanges or similar devices are to be provided on the heating circuits fitted to tanks containing cargoes which are not to be heated.
- d) Heating systems are to be so designed that the pressure maintained in the heating circuits is higher than that exerted by the cargo oil. This need not be applied to

heating circuits which are not in service provided they are drained and blanked-off.

- e) Isolating valves are to be provided at the inlet and outlet connections of the tank heating circuits. Arrangements are to be made to allow manual adjustment of the flow.
- f) Heating pipes and coils inside tanks are to be built of a material suitable for the heated fluid. They are to have welded connections only.

7.1.2 Steam heating

To reduce the risk of liquid or vapour cargo returns inside the engine or boiler rooms, steam heating systems of cargo tanks are to satisfy either of the following provisions:

- a) they are to be independent of other unit services, except cargo heating or cooling systems, and are not to enter machinery spaces, or
- b) they are to be provided with an observation tank on the water return system located within the cargo area. However, this tank may be placed inside the engine room in a well-ventilated position remote from boilers and other sources of ignition. Its air pipe is to be led to the open and fitted with a flame arrester.

7.1.3 Hot water heating

Hot water systems serving cargo tanks are to be independent of other systems. They are not to enter machinery spaces unless the expansion tank is fitted with:

- a) means for detection of flammable vapours
- b) a vent pipe led to the open and provided with a flame arrester.

7.1.4 Thermal oil heating

Thermal oil heating systems serving cargo tanks are to be arranged by means of a separate secondary system, located completely within the cargo area. However, a single circuit system may be accepted provided that:

- a) the system is so arranged as to ensure a positive pressure in the coil of at least 3 m water column above the static head of the cargo when the circulating pump is not in operation
- b) means are provided in the expansion tank for detection of flammable cargo vapours. Portable equipment may be accepted
- c) valves for the individual heating coils are provided with a locking arrangement to ensure that the coils are under static pressure at all times.

8 Bilge system in cargo area

8.1 General

8.1.1 The requirements of this Article apply to bilge systems in cargo area. In addition the applicable requirements for piping systems in Pt C, Ch 1, Sec 10 of the Rules for the Classification of Ships are to be applied.

Bilge systems serving spaces located within the cargo area:

- are to be independent from any piping system serving spaces located outside the cargo area
- are not to lead outside the cargo area.

8.2 Drainage of cofferdams and void spaces located within cargo area

8.2.1 Cofferdams and void spaces located within the cargo area and not intended to be filled with water ballast are to be fitted with suitable means of drainage.

8.3 Drainage of cofferdams located at the fore and aft ends of cargo tanks

8.3.1

- a) When they are not intended to be filled with water ballast, cofferdams located at the fore and aft ends of the cargo tanks are to be fitted with drainage arrangements.
- b) Aft cofferdams adjacent to the cargo pump room may be drained by a cargo pump in accordance with the provisions of [8.4.1] items b) and c), or by bilge ejectors.
- c) Cofferdams located at the fore end of the cargo tanks are to be drained by one or more power pumps fitted in a suitable space forward of cargo tanks or by bilge ejectors.
- d) Drainage of the after cofferdam from the engine room bilge system is not permitted.

8.4 Drainage of pump rooms

8.4.1

- a) Arrangements are to be provided to drain the pump rooms by means of power pumps or bilge ejectors.
- b) Cargo pumps or stripping pumps may be used for draining cargo pump rooms provided that:
 - a screw-down non-return valve is fitted on the bilge suction, and
 - a remote control valve is fitted between the pump suction and the bilge distribution box.
- c) Bilge pipe internal diameter is not to be less than 50 mm.
- d) The bilge system of cargo pump rooms is to be capable of being controlled from outside.
- e) High liquid level in the bilges is to activate an audible and visual alarm in the cargo control room and on the navigation bridge.

8.5 Drainage of tunnels and pump rooms other than cargo pump rooms

8.5.1 Arrangements are to be provided to drain tunnels and pump rooms other than cargo pump rooms. Cargo pumps may be used for this service under the provisions of [8.4.1] b).

Bilge suction pipes to tunnel wells are not to be less than 65 mm in diameter.

9 Ballast system in cargo area

9.1 General

9.1.1 The requirements of this Article apply to ballast systems in cargo area. In addition the applicable requirements for piping systems in Pt C, Ch 1, Sec 10 of the Rules for the Classification of Ships apply.

Unless otherwise specified ballast systems serving spaces located within the cargo area:

- are to be independent from any piping system serving spaces located outside the cargo area;
- are not to lead outside the cargo area;
- are to be completely separated from the cargo oil and fuel oil systems.

9.2 Pumping arrangement for ballast tanks within cargo area

9.2.1 Ballast tanks located within the cargo area are to be served by two different means. At least one of these means is to be a pump or an eductor used exclusively for dealing with ballast.

Ballast pumps are to be located in the cargo pump room, or a similar space within the cargo area not containing any source of ignition.

Where installed in the cargo pump room the relevant prime movers are to be located outside the cargo pump room, except in the following cases:

- steam driven machine supplied with steam having a temperature not exceeding 220 °C
- hydraulic motors
- electric motors of certified type.

Where ballast pumps are driven by a machine which is located in a non hazardous area outside the cargo pump room, the following arrangements are to be made:

- drive shafts are to be fitted with flexible couplings or other means suitable to compensate for any misalignment
- the shaft bulkhead or deck penetration is to be fitted with a gas-tight gland of a type approved by the Society.

The gland is to be efficiently lubricated from outside the oil handling pump room and so designed as to prevent overheating. The seal parts of the gland are to be of material that cannot initiate sparks.

- temperature sensing devices are to be fitted for bulkhead shaft gland bearings and pump casing.

9.3 Emergency discharge of ballast

9.3.1 Provisions may be made for emergency discharge of the ballast by means of a connection to a cargo pump through a detachable spool piece provided that:

- non-return valves are fitted on the ballast connections to prevent the passage of oil to the ballast tank, and
- shut-off valves are fitted to shut off the cargo and ballast lines before the spool piece is removed.

The detachable spool piece is to be placed in a conspicuous position in the pump room and a permanent warning notice restricting its use is to be displayed in a conspicuous position adjacent to it.

9.4 Ballast water in cargo tanks

9.4.1

- Provisions are to be made for filling cargo tanks with sea water, where permitted
- The sea water inlets and overboard discharges serving cargo tanks for the purpose of a) are not to have any connection with the ballast system of ballast tanks.
- Cargo pumps may be used for pumping ballast water to or from the cargo tanks, provided two shut-off valves are fitted to isolate the cargo piping system from the sea inlets and overboard discharges.
- Ballast pumps serving ballast tanks may be used for filling the cargo tanks with sea water provided that the connection is made on the top of the tanks and consists of a detachable spool piece and a screw-down non-return valve to avoid siphon effects.

9.5 Pumping arrangement for cofferdams located at the fore and aft ends of the cargo tanks

9.5.1 Where they are intended to be filled with water ballast, the cofferdams located at the fore and aft ends of the cargo tanks may be emptied by a ballast pump located inside the machinery compartment or a forward space, whichever is the case, provided that:

- the suction is directly connected to the pump and not to a piping system serving machinery spaces
- the delivery is directly connected to the unit side.

9.6 Ballast systems for fore peak

9.6.1 The fore peak tank can be ballasted with the system serving ballast tanks within the cargo area, provided:

- the fore peak tank is considered hazardous
- the vent pipe openings are located on open deck 3 m away from sources of ignition
- means are provided, on the open deck, to allow measurement of flammable gas concentrations within the fore peak tank by a suitable portable instrument
- the sounding arrangement to the fore peak tank is direct from open deck.

9.7 Ballast pipes passing through tanks

9.7.1

- a) Ballast piping is not to pass through cargo tanks except in the case of short lengths of piping complying with the following:
- they are to have welded or heavy flanged joints the number of which is kept to a minimum
 - they are to be of extra-reinforced wall thickness as per Pt C, Ch 1, Sec 10, Tab 5 of the Rules for the Classification of Ships
 - they are to be adequately supported and protected against mechanical damage.
- b) sliding type couplings are not to be used for expansion purposes where ballast lines pass through cargo tanks. Expansion bends only are permitted.

10 Air and sounding pipes of spaces other than cargo tanks in cargo area

10.1 General

10.1.1 The air and sounding pipes fitted to the following spaces:

- cofferdams located at the fore and aft ends of the cargo tanks
- tanks and cofferdams located within the cargo area and not intended for cargo are to be led to the open.

10.2 Air pipes

10.2.1 The air pipes referred to in [10.1.1] are to be arranged as per Pt C, Ch 1, Sec 10, [9] of the Rules for the Classification of Ships and are to be fitted with easily removable flame screens at their outlets.

10.3 Passage through cargo tanks

10.3.1 The air and sounding pipes referred to in [10.1.1] are not to pass through cargo tanks except in the following cases:

- short lengths of piping serving ballast tanks
- lines serving double bottom tanks located within the cargo area

provided that the following provisions are complied with:

- they are to have welded or heavy flanged joints the number of which is kept to a minimum
- they are to be of extra-reinforced wall thickness as per Pt C, Ch 1, Sec 10, Tab 5 of the Rules for the Classification of Ships
- they are to be adequately supported.

11 Scupper pipes in cargo area

11.1

11.1.1 Scupper pipes are not to pass through cargo tanks except, where this is impracticable, in the case of short lengths of piping complying with the following provisions:

- they are of steel
- they have welded or heavy flanged joints the number of which is kept to a minimum
- they are of substantial wall thickness as per Pt C, Ch 1, Sec 10, Tab 23, column 1 of the Rules for the Classification of Ships.

12 Certification, inspection and testing

12.1 Application

12.1.1 The provisions of this Article are related to the venting system, purging and/or gas-freeing system, level gauging systems, protection against overload system, washing systems and heating system of cargo tanks as well as to bilge and ballast systems, air pipes, sounding pipes and scuppers in cargo area.

They supplement those given in Pt C, Ch 1, Sec 10, [10] of the Rules for the Classification of Ships for piping system and in Pt C, Ch 5, Sec 2, [7] for oil handling piping systems.

12.2 Workshop tests

12.2.1 Tests for materials

Where required in Tab 3, materials used for pipes, valves and fittings are to be subjected to the tests specified in Pt C, Ch 1, Sec 10, [21.3.2] of the Rules for the Classification of Ships.

12.2.2 Inspection of welded joints

Where required in Tab 3 welded joints are to be subjected to the examinations specified in Pt C, Ch 1, Sec 10, [3.6] of the Rules for the Classification of Ships.

12.2.3 Hydrostatic testing

- a) Where required in Tab 3, pipes, valves and fittings are to be submitted to hydrostatic tests in accordance with the relevant provisions of Pt C, Ch 1, Sec 10, [21.4] of the Rules for the Classification of Ships.
- b) Expansion joints are to be submitted to hydrostatic tests in accordance with the relevant provisions of Pt C, Ch 1, Sec 10, [21.4] of the Rules for the Classification of Ships.

12.2.4 Tightness tests

Tightness of the following devices is to be checked:

- cargo tank P/V and high velocity valves.

Note 1: These tests may be carried out in the workshops or on board.

12.2.5 Check of the safety valves setting

The setting pressure of the pressure/vacuum valves is to be checked in particular with regard to [2.1.6].

12.2.6 Summarising table

Inspections and tests required for venting system, purging and/or gas-freeing system, level gauging system, protection against overload system, washing system and heating system of cargo tanks as well as for bilge and ballast systems and for air, sounding and scuppers in cargo area are summarised in Tab 3.

12.3 Shipboard tests

12.3.1 Pressure test

- a) After installation on board, the piping system is to be checked for leakage under operational conditions.
- b) Heating oils in cargo tanks are to be tested to not less than 1,5 times the design pressure but in no case less than 0,4 MPa
- c) The piping system used in crude oil washing systems is to be submitted to hydrostatic tests in accordance with App 2, [3.1.1].

12.3.2 Functional tests

The overall performance of the venting system, purging and/or gas-freeing system, level gauging system, protection against overload system, washing system and heating system of cargo tanks as well as bilge and ballast systems are to be verified for compliance with the design parameters during the initial unit operations. Records of the performance of the components and equipment essential to verify the design parameters are to be maintained and be available to the Society.

Table 3 : Inspection and testing at works

No	Item	Test of materials		Inspections and tests for the products			References
		Y/N (1)	Type of material certificate (2)	during Manufacturing (1)	after completion (1) (3)	Type of product certificate (2)	
1	Cargo tank P/V and high velocity valves	Y	C	Y	Y	C	[12.2.1] [12.2.2] (4) [12.2.3] [12.2.4] [12.2.5]
2	flame arresters	N		N	Y	C	(3)

(1) Y = required, N = not required.
(2) C = class certificate
(3) includes the checking of the rule characteristics according to the approved drawings.
(4) Only in the case of welded construction

SECTION 5

ELECTRICAL INSTALLATIONS

1 General

1.1 Application

1.1.1 The requirements in this Section apply to FSO units in addition to those contained in Part C, Chapter 2.

1.2 Documentation to be submitted

1.2.1 In addition to the documentation requested in Pt C, Ch 2, Sec 1, Tab 1 of the Rules for the Classification of Ships, the following are to be submitted for approval:

- a) plan of hazardous areas
- b) document giving details of types of cables and safety characteristics of the equipment installed in hazardous areas
- c) diagrams of tank level indicator systems, high level alarm systems and overflow control systems where requested.

1.3 Monitoring of circuit in hazardous areas

1.3.1 The device intended to continuously monitor the insulation level of all distribution system are also to monitor all circuits, other than intrinsically safe circuits, connected to apparatus in hazardous areas or passing through such areas. An audible and visual alarm is to be given, at a manned position, in the event of an abnormally low level of insulation.

Systems fed by single transformers supplying one consumer or a control circuit do not require an earth fault detection.

1.4 Precautions against inlet of gases or vapours

1.4.1 Suitable arrangements are to be provided, to the satisfaction of the Society, so as to prevent the possibility of gases or vapours passing from a gas-dangerous space to another space through runs of cables or their conduits.

2 Hazardous location classification and permitted electrical equipment

2.1 General

2.1.1 Units are to be assessed with regard to any potential explosive gas atmosphere in accordance with the provisions of [2] or alternatively with an acceptable Code or Standard giving equivalent safety.

2.1.2 The results are to be documented in area classification drawings to allow the proper selection of all electrical components to be installed.

2.1.3 The hazardous location classification is to be carried out by those who have knowledge of the properties of flammable materials, the process and the equipment, in consultation with, as appropriate, safety, electrical, mechanical and other engineering personnel.

2.1.4 Classification of hazardous areas in ZONES is defined in Pt C, Ch 2, Sec 1, [3.24] of the Rules for the Classification of Ships.

2.1.5 Release as a result of accidental events such as blow-out or vessel rupture is not addressed by area classification. It is to be covered by emergency measures.

2.1.6 Openings, penetrations or connections between areas of different hazardous area classification are to be avoided, e.g. through ventilation systems, air pipes or drain systems.

2.1.7 Enclosed or semi-enclosed spaces (not containing a source of hazard) having a direct opening, including those for ventilation, into any hazardous area are to be designated as the same hazardous zone as the area in which the opening is located. See also [2.1.6] and [2.1.9]. Electrical installations are to comply with the requirements for the space or area into which the opening leads.

2.1.8 Electrical installations in spaces protected by airlocks are to be of a certified safe type unless arranged to be de-energised upon loss of overpressure in the space.

2.1.9 Except for operational reasons, access doors or other openings are not to be provided between a non-hazardous space and a hazardous area or between a zone 2 space and a zone 1 space. Where such access doors or other openings are provided, any non-hazardous enclosed space having a direct access to any zone 1 location or zone 2 location becomes the same zone as the location except that:

- a) an enclosed space with direct access to any zone 1 location can be considered as zone 2 if:
 - the access is fitted with a gastight door opening into the zone 2 space, and
 - ventilation is such that the air flow with the door open is from the zone 2 space into the zone 1 location, and
 - loss of ventilation is alarmed at a manned station;
- b) an enclosed space with direct access to any zone 2 location is not considered hazardous if:
 - the access is fitted with a self-closing gastight door that opens into the non-hazardous location, and
 - ventilation is such that the air flow with the door open is from the non-hazardous space into the zone 2 location, and
 - loss of ventilation is alarmed at a manned station;

- c) an enclosed space with direct access to any zone 1 location is not considered hazardous if:
- the access is fitted with self-closing gastight doors forming an airlock, and
 - the space has ventilation overpressure in relation to the hazardous space, and
 - loss of ventilation overpressure is alarmed at a manned station.

Where ventilation arrangements for the intended safe space are considered sufficient by the Society to prevent any ingress of gas from the zone 1 location, the two self-closing doors forming an airlock may be replaced by a single self-closing gastight door which opens into the non-hazardous location and has no hold-back device.

2.1.10 Piping systems are to be designed to preclude direct communication between hazardous areas of different classifications and between hazardous and non-hazardous areas.

2.2 Ventilation

2.2.1 For requirements of ventilation systems in hazardous areas, see Pt C, Ch 4, Sec 2, [3.5] and Sec 6, [4].

2.3 Protection in overpressure

2.3.1 For requirements relevant to protection in overpressure, see Pt C, Ch 4, Sec 2, [3.6].

2.4 Hazardous area and electrical equipment

2.4.1 Electrical installations are to be such as to minimize the risk of fire and explosion from flammable products.

2.4.2 Electrical equipment and cables installed in hazardous areas are to be limited to those necessary for operational purposes.

2.4.3 Where electrical equipment is installed in gas-dangerous spaces or zones and is essential for operational purposes, it should be of a safe type for operation in the flammable atmosphere concerned.

2.4.4 Portable electrical equipment, supplied by cables is not permitted in hazardous areas, unless special precautions are taken (see IEC 61892-7 clause 6.5).

2.4.5 For FSO units storing flammable liquids having a flash point not exceeding 60°C see Tab 1.

2.4.6 For FSO units storing flammable liquids having a flash point exceeding 60°C see Tab 2.

2.4.7 For FSO units storing cargoes heated to a temperature above their flash point and cargoes heated to a temperature within 15°C of their flash point, the requirements under [2.4.5] apply.

2.4.8 The explosion group and temperature class of electrical equipment of a certified safe type are to be at least IIA and T3 in the case of units arranged for the carriage of crude oil or other petroleum products.

2.4.9 Other characteristics may be required for dangerous products other than those above. In this case permitted certified safe type electrical equipment is to be chosen taking into account the more demanding of the required explosion groups and temperature classes of the cargoes allowed to be stored.

2.4.10 For electrical cables see Pt C, Ch 2, Sec 2, [12.2].

2.4.11 The cross-section of cables installed in hazardous areas is to be correlated to the characteristics time/current of the relevant electrical protective device in order to limit the surface temperature of the cable to a safety value obliged by the temperature class of the dangerous gas likely to be present in the area, under the most severe expected fault condition.

3 Sources of electrical power and distribution systems

3.1 Power sources location

3.1.1 Sources of electrical power and their section boards and distribution boards, etc., are normally not to be located in hazardous locations.

The generating plant, switchboards and batteries are to be separated from any zone 0 by cofferdams or equivalent spaces and from other hazardous areas by gas-tight steel divisions.

Access between such spaces have to comply with [2.1.9].

Table 1 : Hazardous location classification and permitted electrical equipment - FSO units storing flammable liquids having a flashpoint not exceeding 60°C

Hazardous area	Spaces		Electrical equipment
	N°	Description	
Zone 0	1	Interior of cargo tanks, slop tanks, any pipework of pressure relief or other venting systems for cargo and slop tanks, pipes and equipment containing cargo or developing flammable gases or vapours.	<ul style="list-style-type: none"> a) certified intrinsically safe apparatus Ex(ia); b) simple electrical apparatus and components (e.g. thermocouples, photocells, strain gauges, switching devices), included in intrinsically safe circuits of category "ia" not capable of storing or generating electrical power or energy in excess of limits stated in the relevant standards c) equipment specifically designed and certified by the appropriate authority for use in Zone 0.
Zone 1	2	Void spaces adjacent to, above or below integral cargo tanks.	<ul style="list-style-type: none"> a) any type considered for Zone 0; b) certified intrinsically safe apparatus Ex(ib); c) simple electrical apparatus and components (e.g. thermocouples, photocells, strain gauges, switching devices), included in intrinsically safe circuits of category "ib" not capable of storing or generating electrical power or energy in excess of limits stated in the relevant standards; d) hull fittings containing the terminals or shell plating penetrations for anodes or electrodes of an impressed current cathodic protection system, or transducers such as those for depth sounding or log systems, provided that such fittings are of gas-tight construction or housed within a gas-tight enclosure and are not located adjacent to a cargo tank bulkhead. The design of such fittings or their enclosures and the means by which cables enter, as well as any testing to establish their gas-tightness, are to be to the satisfaction of the Society. The associated cables are to be protected as indicated in item e); e) electrical cables passing through the spaces. Such cables are to be installed in heavy gauge steel pipes with gas-tight joints. Expansion bends are not to be fitted in these spaces.
Zone 1	3	Hold spaces containing independent cargo tanks.	<ul style="list-style-type: none"> a) any type considered for Zone 0; b) certified intrinsically safe apparatus Ex(ib); c) simple electrical apparatus and components (e.g. thermocouples, photocells, strain gauges, switching devices), included in intrinsically safe circuits of category "ib" not capable of storing or generating electrical power or energy in excess of limits stated in the relevant standards; d) Zone 1 certified safe type lighting fittings divided between at least two independent final sub-circuits. All switches and protective devices are to interrupt all poles or phases and are to be located in a non-hazardous area; e) hull fittings containing the terminals or shell plating penetrations for anodes or electrodes of an impressed current cathodic protection system, or transducers such as those for depth sounding or log systems, provided that such fittings are of gas-tight construction or housed within a gas-tight enclosure and are not located adjacent to a cargo tank bulkhead. The design of such fittings or their enclosures and the means by which cables enter, as well as any testing to establish their gas-tightness, are to be to the satisfaction of the Society; f) electrical cables passing through the spaces.

Hazardous area	Spaces		Electrical equipment
	N°	Description	
Zone 1	4	Cofferdams and permanent (for example, segregated) ballast tanks adjacent to cargo tanks.	<ul style="list-style-type: none"> a) any type considered for Zone 0; b) certified intrinsically safe apparatus Ex(ib); c) simple electrical apparatus and components (e.g. thermocouples, photocells, strain gauges, switching devices), included in intrinsically safe circuits of category "ib" not capable of storing or generating electrical power or energy in excess of limits stated in the relevant standards; d) hull fittings containing the terminals or shell plating penetrations for anodes or electrodes of an impressed current cathodic protection system, or transducers such as those for depth sounding or log systems, provided that such fittings are of gas-tight construction or housed within a gas-tight enclosure and are not located adjacent to a cargo tank bulkhead. The design of such fittings or their enclosures and the means by which cables enter, as well as any testing to establish their gas-tightness, are to be to the satisfaction of the Society. The associated cables are to be protected as indicated in item e); e) electrical cables passing through the spaces. Such cables are to be installed in heavy gauge steel pipes with gas-tight joints. Expansion bends are not to be fitted in these spaces. Corrosion-resistant pipes, providing adequate mechanical protection, are to be used in compartments which may be filled with sea water (e.g. permanent ballast tanks).
Zone 1	5	Cargo pump rooms.	<ul style="list-style-type: none"> a) any type considered for Zone 0; b) certified intrinsically safe apparatus Ex(ib); c) simple electrical apparatus and components (e.g. thermocouples, photocells, strain gauges, switching devices), included in intrinsically safe circuits of category "ib" not capable of storing or generating electrical power or energy in excess of limits stated in the relevant standards; d) hull fittings containing the terminals or shell plating penetrations for anodes or electrodes of an impressed current cathodic protection system, or transducers such as those for depth sounding or log systems, provided that such fittings are of gas-tight construction or housed within a gas-tight enclosure and are not located adjacent to a cargo tank bulkhead. The design of such fittings or their enclosures and the means by which cables enter, as well as any testing to establish their gas-tightness, are to be to the satisfaction of the Society. The associated cables are to be protected as indicated in item g); e) Zone 1 certified safe lighting fittings divided between at least two independent final sub-circuits. All switches and protective devices are to interrupt all poles or phases and are to be located in a non-hazardous area. The lighting fittings, switches and protective devices are to be suitably labelled for identification purposes. See also Sec 6, [4.2.3]; f) Zone 1 certified safe type visual and/or acoustic indicators (e.g. for general alarm, fire-extinguishing media alarm, etc.); g) Zone 1 certified safe type sensors for gas detection systems; h) cables, other than those supplying lighting fittings and those of intrinsically safe circuits, where it is necessary for them to pass through cargo pump rooms. Such cables are to be installed in heavy gauge steel pipes with gas-tight joints.

Hazardous area	Spaces		Electrical equipment
	N°	Description	
Zone 1	6	Enclosed or semi-enclosed spaces immediately above cargo tanks (e.g. 'tweendecks) or having bulkheads above and in line with cargo tank bulkheads, unless protected by a diagonal plate acceptable to the Society.	<p>a) any type considered for Zone 0;</p> <p>b) certified intrinsically safe apparatus Ex(ib);</p> <p>c) simple electrical apparatus and components (e.g. thermocouples, photocells, strain gauges, switching devices), included in intrinsically safe circuits of category "ib" not capable of storing or generating electrical power or energy in excess of limits stated in the relevant IEC or EN Standards;</p> <p>d) Zone 1 certified safe type lighting fittings divided between at least two independent final sub-circuits. All switches and protective devices are to interrupt all poles or phases and are to be located in a non-hazardous area. The lighting fittings, switches and protective devices are to be suitably labelled for identification purposes;</p> <p>e) electrical cables passing through the spaces;</p> <p>f) in 'tweendeck spaces immediately above cargo tanks, any electrical equipment other than that in (a), (b), (c) and (d), provided that it is housed in a compartment: <ul style="list-style-type: none"> • which is suitably mechanically ventilated, • having access solely from the deck above, • whose floor is separated from the cargo tanks by a cofferdam, • whose boundaries are oil-tight and gas-tight with respect to the cofferdam and the 'tweendeck spaces. </p>
Zone 1	7	Spaces other than cofferdams, adjacent to and below the top of a cargo tank (e.g. trunks, passageways and holds) as well as double bottoms and pipe tunnels below cargo tanks.	<p>a) any type considered for Zone 0;</p> <p>b) certified intrinsically safe apparatus Ex(ib);</p> <p>c) simple electrical apparatus and components (e.g. thermocouples, photocells, strain gauges, switching devices), included in intrinsically safe circuits of category "ib" not capable of storing or generating electrical power or energy in excess of limits stated in the relevant standards;</p> <p>d) hull fittings containing the terminals or shell plating penetrations for anodes or electrodes of an impressed current cathodic protection system, or transducers such as those for depth sounding or log systems, provided that such fittings are of gas-tight construction or housed within a gas-tight enclosure and are not located adjacent to a cargo tank bulkhead. The design of such fittings or their enclosures and the means by which cables enter, as well as any testing to establish their gas-tightness, are to be to the satisfaction of the Society. The associated cables are to be protected as indicated in item f);</p> <p>e) Zone 1 certified safe type lighting fittings divided between at least two independent final sub-circuits. All switches and protective devices are to interrupt all poles or phases and are to be located in a non-hazardous area. The lighting fittings, switches and protective devices are to be suitably labelled for identification purposes;</p> <p>f) electrical cables passing through the spaces; through-runs of cables, with the exception of those for intrinsically safe apparatus, will be specially considered by the Society.</p>

Hazardous area	Spaces		Electrical equipment
	N°	Description	
Zone 1	8	Areas on open deck, or semi-enclosed spaces on open deck, within 3m of any cargo tank outlet (tank hatches, sight ports, tank cleaning openings, ullage openings, sounding pipes etc.), cargo manifold valves, cargo valves, cargo pipe flanges, cargo pump room and other enclosed hazardous space entrance(s) and ventilation outlets, and cargo tank ventilation outlets and cargo tank openings for pressure release provided to permit the flow of small volumes of gas or vapour mixtures caused by thermal variation.	<ul style="list-style-type: none"> a) any type considered for Zone 0; b) certified intrinsically safe apparatus Ex(ib); c) simple electrical apparatus and components (e.g. thermocouples, photocells, strain gauges, switching devices), included in intrinsically safe circuits of category "ib" not capable of storing or generating electrical power or energy in excess of limits stated in the relevant standards; d) certified flameproof Ex(d); e) certified pressurised Ex(p); f) certified increased safety Ex(e); g) certified encapsulated Ex(m); h) certified sand filled Ex(q); i) electrical cables passing through the spaces. Expansion bends are not to be fitted in these spaces.
Zone 1	9	Areas on open deck, or semi-enclosed spaces on open deck, above and in the vicinity of any cargo gas outlet intended for the passage of large volumes of gas or vapour mixture during cargo loading and ballasting or during discharging, within a vertical cylinder of unlimited height and 6m radius centred upon the centre of the outlet, and within a hemisphere of 6m radius below the outlet.	As allowed for spaces under item 8.
Zone 1	10	Areas on open deck, or semi-enclosed spaces on open deck, within 1,5m of cargo pump room entrances, cargo pump room ventilation inlets, openings into cofferdams or other Zone 1 spaces.	As allowed for spaces under item 8.
Zone 1	11	Areas on open deck within spillage coamings surrounding cargo manifold valves and 3 m beyond these, up to a height of 2,4 m above the deck.	As allowed for spaces under item 8.
Zone 1	12	Areas on open deck over all cargo tanks (including all ballast tanks within the cargo tank area) where structures are restricting the natural ventilation and to the full breadth of the unit plus 3m fore and aft of the forward-most and aft-most cargo tank bulkhead, up to a height of 2,4m above the deck.	As allowed for spaces under item 8 except that expansion bends are allowed in these areas.
Zone 1	13	Compartments for cargo hoses.	As allowed for spaces under item 7 a) b) c) e) and electrical cables passing through the space.
Zone 1	14	Enclosed or semi-enclosed spaces in which pipes containing cargoes are located.	As allowed for spaces under item 13.
Zone 2	15	Areas of 1,5 m surrounding the Zone 1 spaces defined in item 8.	<ul style="list-style-type: none"> a) any type considered for Zone 1; b) electrical equipment of a type which ensures the absence of sparks, arcs and "hot spots" during its normal operation; c) electrical equipment tested specially for Zone 2 (e.g. type "n" protection); d) electrical equipment encapsulated and acceptable to the Society.
Zone 2	16	Areas 4m beyond the cylinder and 4m beyond the sphere defined in item 9.	As allowed for spaces under item 15.

Hazardous area	Spaces		Electrical equipment
	N°	Description	
Zone 2	17	Areas on open deck extending to the coamings fitted to keep any spills on deck and away from the accommodation and service areas and 3m beyond these up to a height of 2,4m above the deck.	As allowed for spaces under item 15.
Zone 2	18	Areas on open deck over all cargo tanks (including all ballast tanks within the cargo tank area) where unrestricted natural ventilation is guaranteed and to the full breadth of the unit plus 3m fore and aft of the forward-most and aft-most cargo tank bulkhead, up to a height of 2,4m above the deck surrounding open or semi-enclosed spaces of Zone 1.	As allowed for spaces under item 15.
Zone 2	19	Spaces forward of the open deck areas to which reference is made in item 13 and item 19, below the level of the main deck, and having an opening on the main deck or at a level less than 0,5m above the main deck, unless: a) the entrances to such spaces do not face the cargo tank area and, together with all other openings to the spaces, including ventilation system inlets and exhausts, are situated at least 5m from the foremost cargo tank and at least 10m measured horizontally from any cargo tank outlet or gas or vapour outlet; and b) the spaces are mechanically ventilated.	As allowed for spaces under item 15.

Table 2 : Hazardous location classification and permitted electrical equipment - FSO units storing flammable liquids having a flashpoint exceeding 60°C unheated or heated to a temperature below and not within 15°C of their flashpoint

Hazardous area	Spaces		Electrical equipment
	N°	Description	
Zone 2	1	Interior of cargo tanks, slop tanks, any pipework of pressure relief or other venting systems for cargo and slop tanks, pipes and equipment containing cargo	a) any type considered for Zone 1; b) electrical equipment of a type which ensures the absence of sparks, arcs and "hot spots" during its normal operation; c) electrical equipment tested specially for Zone 2 (e.g. type "n" protection);

SECTION 6

FIRE PROTECTION, DETECTION AND EXTINCTION

1 General

1.1 Application

1.1.1 The requirements of this Section, with the exception of items [4] and [6] are not applicable for the purpose of classification, except where the Society carries out surveys relevant to fire protection statutory requirements on behalf of the Flag Administration. In such cases, unless otherwise provided by the Flag Administration, fire protection statutory requirements as contained in this Chapter 1 are considered a matter of class and their compliance is verified by the Society for classification purposes.

1.1.2 Requirements contained in this Chapter are additional to those contained in Part C, Chapter 4, Section 2 except for item [2.2] that is to be applied in lieu of Pt C, Ch 4, Sec 2, [3.2.1] a) and Pt C, Ch 4, Sec 2, [3.2.6] a).

1.2 Documentation to be submitted

1.2.1 In addition to those listed under Pt C, Ch 4, Sec 2, Tab 1, the documents listed in the following table are to be submitted for approval.

2 Cargo area

2.1 Separation of cargo oil tanks

2.1.1 SOLAS regulation II-2/4.5.1 applies taking into account the unit's lay-out.

2.2 Restriction on boundary openings

2.2.1 SOLAS regulation II-2/4.5.2 applies taking into account the unit's lay-out.

Table 1 : Documents to be submitted

No	(1)	Document (2)
1	A	Fixed deck foam systems
2	A	Fixed fire extinguishing systems in cargo pump rooms
3	A	Arrangement of fixed inert gas systems
<p>(1) A : to be submitted for approval, in four copies</p> <p>(2) Plans are to be schematic and functional and to contain all information necessary for their correct interpretation and verification, such as:</p> <ul style="list-style-type: none"> • service pressures • capacity and head of pumps and compressors, if any • materials and dimensions of piping and associated fittings • volumes of protected spaces, for gas and foam fire-extinguishing systems • surface areas of protected zones for automatic sprinkler and pressure water-spraying, low expansion foam and powder fire-extinguishing systems • capacity, in volume and/or in mass, of vessels or bottles containing the extinguishing media or propelling gases, for gas, automatic sprinkler, foam and powder fire-extinguishing systems • type, number and location of nozzles of extinguishing media for gas, automatic sprinkler, pressure water-spraying, foam and powder fire-extinguishing systems. <p>All or part of the information may be provided, instead of on the above plans, in suitable operating manuals or in specifications of the systems.</p>		

2.3

2.3.1 Drip pans for collecting residues in cargo lines and hoses are to be provided in the area of pipe and hose connections under the manifold area. Cargo hoses and tank washing hoses are to have electrical continuity over their entire lengths including couplings and flanges (except shore connections) and are to be earthed for removal of electrostatic charges.

3 Structural fire protection

3.1

3.1.1 Exterior boundaries of superstructures and deckhouses enclosing accommodation spaces, services spaces, control stations and machinery spaces including any overhanging decks which support such spaces, are to be constructed to "A-60" standard for the whole of the portion which faces the tank area, and on the outward sides for a distance of 3 m from the end boundary facing the tank cargo area. In the case of the sides of those superstructures and deckhouses, such insulation is to be carried up to the underside of the deck of the navigation bridge, where fitted.

3.1.2 Boundaries separating cargo pump rooms and machinery spaces of category A are to meet at least the A-0 class standard.

4 Ventilation systems in hazardous spaces

4.1 Ventilation of other enclosed or semi-enclosed spaces within tank area

4.1.1 The ventilation system of these spaces is to have sufficient capacity to minimize the possibility of accumulation of flammable vapours. The number of changes of air is to be at least 20 per hour, based upon the gross volume of the space. The air ducts are to be arranged so that all of the space is effectively ventilated. Different values of air changes may be required or accepted by the Society based on the purpose of the space under consideration.

4.2 Ventilation of cargo pump rooms

4.2.1 The ventilation is to have sufficient capacity to minimize the possibility of accumulation of flammable vapours. The number of changes of air is to be at least 20 per hour, based upon the gross volume of the space. The air ducts are to be arranged so that all of the space is effectively ventilated.

4.2.2 The ventilation system capable of providing the required air changes per hour is to comply with the following:

- a) in order to avoid air stagnation zones, air exhaust ports inside the pump room are to be adequately distributed and the various landings are to consist of open gratings or perforated flats
- b) inlet ducts are generally to end at the top of the room and outlet ducts are to extend below the floor plates, with suction ports at the level of the upper edge of ordinary floors or bottom longitudinals
- c) in addition, suction ducts are to be provided with an emergency intake at approximately 2,20 m above the pump room lower grating, with a shutter capable of being opened or closed both at lower grating level and from the weather deck level, so that suction normally occurs through the lower suction ports and, in the event of the pump room flooding, through those at the top branched from the emergency intake
- d) an arrangement involving a specific ratio of areas of upper emergency and lower main ventilator openings, which can be shown to result in at least the required 20 air changes per hour through the lower inlets, can be adopted without the use of shutters. When the lower access inlets are closed then at least 15 air changes per hour are to be obtained through the upper inlets.

4.2.3 Lighting in cargo pump rooms, except emergency lighting, is to be interlocked with ventilation such that the ventilation is in operation when the lighting is switched on. Failure of the ventilation system is not to cause the lighting to go out.

5 Active fire protection

5.1 Fixed deck foam system

5.1.1 General requirements

- a) The cargo tank deck area is to be protected by a fixed deck foam system capable of delivering foam to the entire cargo tank deck area (including loading and discharge manifold area) as well as into any cargo tank the deck of which has been ruptured.
- b) The deck foam system is to be capable of simple and rapid operation.
- c) Operation of a deck foam system at its required output is to permit the simultaneous use of the minimum required number of jets of water at the required pressure from the fire main at any location.
- d) A common line for fire main and deck foam line can only be accepted if it can be demonstrated that the hose nozzles can be effectively controlled by one person when supplied from the common line at a pressure needed for operation of the monitors. Additional foam concentrate is to be provided for operation of 2 nozzles for the same period of time required for the foam system. The simultaneous use of the minimum required jets of water is to be possible on deck over the full length of the unit, in the accommodation spaces, service spaces, control stations and machinery spaces.

5.1.2 Component requirements

a) Foam solution and foam concentrate

The rate of supply of foam solution is to be not less than the greatest of the following:

- 0,6 l/min per square metre of cargo tanks deck area, where cargo tank deck area means the maximum breadth of the unit multiplied by the total longitudinal extent of the cargo tank spaces
- 6 l/min per square metre of the horizontal sectional area of the single tank having the largest such area, or
- 3 l/min per square metre of the area protected by the largest monitor, such area being entirely forward of the monitor, but not less than 1250 l/min.

b) Sufficient foam concentrate is to be supplied to ensure at least 20 min of foam generation in units fitted with an inert gas installation or 30 min of foam generation in units not fitted with an inert gas installation when using solution rates stipulated in item 1 above, whichever is the greatest. The foam expansion ratio (i.e. the ratio of the volume of foam produced to the volume of the mixture of water and foam-making concentrate supplied) is not generally to exceed 12 to 1. Where systems essentially produce low expansion foam but at an expansion ratio slightly in excess of 12 to 1 the quantity of foam solution available is to be calculated as for 12 to 1 expansion ratio systems (see Note 1). When medium expansion ratio foam (see Note 2) (between 50 to 1 and 150 to 1 expansion ratio) is employed, the application rate of the foam and the capacity of a monitor installation are to be to the satisfaction of the Society.

Note 1: Refer to the Guidelines for the performance and testing criteria and surveys of low-expansion foam concentrates for fixed fire-extinguishing systems (MSC/Circ.1312).

Note 2: Refer to the Guidelines for the performance, testing criteria and surveys of medium expansion foam concentrates for fixed fire-extinguishing systems (MSC/Circ.798).

5.1.3 Monitors and foam applicators

- a) Foam from the fixed foam system is to be supplied by means of monitors and foam applicators. At least 50 per cent of the foam solution supply rate required in the first two items of [5.1.2] a) is to be delivered from each monitor. On units of less than 4000 tonnes deadweight, the Society may not require installation of monitors but only applicators. However, in such case the capacity of each applicator is to be at least 25 per cent of the foam solution supply rate required in the first two items of [5.1.2] a).
- b) The capacity of any monitor is to be at least 3 l/minute of foam solution per square metre of deck area protected by that monitor, such area being entirely forward of the monitor. Such capacity is to be not less than 1250 l/minute.
- c) The capacity of any applicator is to be not less than 400 l/min and the applicator throw in still air conditions is to be not less than 15 m.

5.1.4 Installation requirements

a) Main control station

The main control station for the system is to be suitably located outside the cargo area, adjacent to the accommodation spaces and readily accessible and operable in the event of fire in the areas protected.

b) Monitors

The number and position of monitors are to be such as to comply with previous item [5.1.1] a).

The distance from the monitor to the farthest extremity of the protected area forward of that monitor is to be not more than 75 per cent of the monitor throw in still air conditions.

A monitor and hose connection for a foam applicator are to be situated both port and starboard at the front of the poop or accommodation spaces facing the cargo tank deck. On units of less than 4000 tonnes deadweight a hose connection for a foam applicator is to be situated both port and starboard at the front of the poop or accommodation spaces facing the cargo tank deck.

5.1.5 Applicators

- a) The number of foam applicators provided is to be not less than four. The number and disposition of foam main outlets are to be such that foam from at least two applicators can be directed on to any part of the cargo tank deck area.
- b) Applicators are to be provided to ensure flexibility of action during fire-fighting operations and to cover areas screened from the monitors.

5.1.6 Isolation valves

Valves are to be provided in the foam main, and in the fire main when this is an integral part of the deck foam system, immediately forward of any monitor position to isolate damaged sections of those mains.

5.2 Protection of cargo pump rooms

5.2.1 Each cargo pump room is to be provided with one of the following fixed fire-extinguishing systems operated from a readily accessible position outside the pump room. Cargo pump rooms are to be provided with a system suitable for machinery spaces of category A.

- a) A carbon dioxide system complying with the provisions Chapter 5 of the Fire Safety Systems Code and with the following:
- the alarms giving audible warning of the release of fire-extinguishing medium are to be safe for use in a flammable cargo vapour/air mixture; and
 - a notice is to be exhibited at the controls stating that, due to the electrostatic ignition hazard, the system is to be used only for fire extinguishing and not for inerting purposes.

- b) A high-expansion foam system complying with the provisions Chapter 6 of the Fire Safety Systems Code, provided that the foam concentrate supply is suitable for extinguishing fires involving the cargoes carried.
- c) A fixed pressure water-spraying system complying with the provisions of Chapter 7 of the Fire Safety Systems Code.

5.3 Protection of other enclosed spaces within the cargo tank deck area

5.3.1 The requirements set out in item [5.2] are applicable, at the discretion of the Society, to any other enclosed or semi-enclosed space within the cargo tank deck area.

6 Fire and gas detection

6.1 Gas detection system

6.1.1 A fixed gas detection system is to be provided for the following areas:

- hazardous areas, except in Zone 0 and areas mechanically ventilated;
- ventilation outlets from hazardous areas mechanically ventilated;
- intakes for ventilation air, including those for accommodation spaces, service spaces and control stations.

Where the atmosphere in double hull spaces cannot be reliably measured using flexible gas sampling hoses, such spaces shall be fitted with permanent gas sampling lines. The configuration of gas sampling lines shall be adapted to the design of such spaces.

6.1.2 The gas detection system is to indicate both by audible and visible alarm in the control centre the presence of an accumulation of gas corresponding to 25% and 60% of LEL.

6.1.3 In cases where concentration of H₂S is expected, equipment suitable for measuring H₂S is to be installed. Visual and audible alarms are to be activated in the main control stations at 10 ppm H₂S.

6.1.4 In cargo pump room, sampling points or detector heads shall be located in suitable positions in order that potentially dangerous leakage is readily detected. Suitable positions may be the exhaust ventilation duct and lower parts of the pump room above the floor plates.

When the gas concentration reaches a pre-set level, which shall not be higher than 10% LFL, a continuous audible and visual alarm signal shall be automatically initiated in the pump-room and to continuously manned stations to alert personnel to the potential hazard.

Sequential sampling is acceptable as long as it is dedicated for the pump room only, including exhaust ducts, and the sampling time is reasonably short.

7 Personnel protection

7.1 Firefighter's outfits

7.1.1 Two fire fighter's outfits are to be provided, in addition to those required in Pt C, Ch 4, Sec 2, [5.8.2].

8 Inert gas system

8.1 Application

8.1.1 The protection of the cargo tanks is to be achieved by a fixed inert gas system designed, constructed and tested in accordance with the requirements of Chapter 15 of the Fire Safety System Code, except that, in lieu of the above, the Society, after having given consideration to the unit's arrangement and equipment, may accept other fixed installations if they afford protection equivalent to the above.

The requirements for alternative installations are given in [8.3] below.

8.1.2 Units operating with a cargo tank cleaning procedure using crude oil washing, are to be fitted with an inert gas system complying with the requirements of Chapter 15 of the Fire Safety System Code and with fixed tank washing machines.

8.1.3 Units required to be fitted with inert gas systems are to comply with the following provisions:

- double hull spaces are to be fitted with suitable connections for the supply of inert gas
- where hull spaces are connected to a permanently fitted inert gas distribution system, means are to be provided to prevent hydrocarbon gases from the cargo tanks entering the double hull space through the system and
- where such spaces are not permanently connected to an inert gas distribution system, appropriate means are to be provided to allow connection to the inert gas main.

8.2 General requirements for inert gas systems

8.2.1 The inert gas system is to be capable of inerting, purging and gas-freeing empty cargo tanks and maintaining the atmosphere in cargo tanks with the required oxygen content.

8.2.2 Units fitted with a fixed inert gas system are to be provided with a closed ullage system.

8.3 Requirements for equivalent systems

8.3.1 -

When an installation equivalent to a fixed inert gas system is installed, it is to be:

- capable of preventing dangerous accumulations of explosive mixtures in intact cargo tanks during normal service throughout the ballast condition and necessary in-tank operations, and
- so designed as to minimise the risk of ignition from the generation of static electricity by the system itself.

APPENDIX 1

DEVICES TO PREVENT THE PASSAGE OF FLAME INTO THE CARGO TANKS

1 General

1.1 Application

1.1.1 This Appendix is intended to cover the design, testing, location and maintenance of "devices to prevent the passage of flame into cargo tanks" (hereafter called "devices") of FSO.

1.1.2 Units fitted with an inert gas system in accordance with Sec 6, [8] are to be fitted with devices which comply with this Appendix, except that the tests specified in [4.2.3] and [4.3.3] are not required. Such devices are only to be fitted at openings unless they are tested in accordance with [4.4].

Note 1: This Appendix is intended for devices protecting cargo tanks containing crude oil and petroleum products. Devices are to be tested and located in accordance with this Appendix.

1.1.3 Devices are installed to protect:

- a) openings designed to relieve pressure or vacuum caused by thermal variations (see Sec 4, [2.1.2], item a));
- b) openings designed to relieve pressure or vacuum during cargo loading, ballasting or discharging (see Sec 4, [2.1.2], item b));
- c) outlets designed for gas-freeing (see Sec 4, [3.1.1]).

1.1.4 Devices are not to be capable of being bypassed or blocked open unless they are tested in the bypassed or blocked open position in accordance with [4].

1.1.5 This Appendix does not include consideration of sources of ignition such as lightning discharges, since insufficient information is available to formulate equipment recommendations. All cargo handling, tank cleaning and ballasting operations are to be suspended on the approach of an electrical storm.

1.1.6 This Appendix is not intended to deal with the possibility of the passage of flame from one cargo tank to another on tankers with common venting systems.

1.1.7 When outlet openings of gas-freeing systems on tankers not fitted with inert gas systems are required to be protected with devices, they are to comply with this Appendix except that the tests specified in [4.2.3] and [4.3.3] are not required.

1.1.8 Certain of the tests prescribed in [4] of this Appendix are potentially hazardous, but no attempt is made in this Appendix to specify safety requirements for these tests.

1.2 Definitions

1.2.1 Premise

For the purpose of this Appendix, the definitions given in the following paragraphs are applicable.

1.2.2 Flame arrester

A flame arrester is a device to prevent the passage of flame in accordance with a specified performance standard. Its flame arresting element is based on the principle of quenching.

1.2.3 Flame screen

A flame screen is a device utilising wire mesh to prevent the passage of unconfined flames in accordance with a specified performance standard.

1.2.4 Flame speed

The flame speed is the speed at which a flame propagates along a pipe or other system.

1.2.5 Flashback

Flashback is the transmission of a flame through a device.

1.2.6 High velocity vent

A high velocity vent is a device to prevent the passage of flame consisting of a mechanical valve which adjusts the opening available for flow in accordance with the pressure at the inlet of the valve in such a way that the efflux velocity cannot be less than 30 m/s.

1.2.7 Pressure/vacuum valve

A pressure/vacuum valve is a device designed to maintain pressure and vacuum in a closed container within preset limits.

Note 1: Pressure/vacuum valves are devices to prevent the passage of flame when designed and tested in accordance with this Appendix.

1.3 Instruction manual

1.3.1 The manufacturer is to supply a copy of the instruction manual, which is to be kept on board the tanker and which is to include:

- a) installation instructions
- b) operating instructions
- c) maintenance requirements, including cleaning (see [2.3.3])
- d) a copy of the laboratory report referred to in [4.6]
- e) flow test data, including flow rates under both positive and negative pressures, operating sensitivity, flow resistance and velocity.

2 Design of the devices

2.1 Principles

2.1.1 Depending on their service and location, devices are required to protect against the propagation of:

- a) moving flames, and/or
- b) stationary flames from pre-mixed gases after ignition of gases resulting from any cause.

2.1.2 When flammable gases from outlets ignite, the following four situations may occur:

- a) at low gas velocities the flame may:
 - 1) flashback, or
 - 2) stabilise itself as if the outlet were a burner.
- b) at high gas velocities, the flame may:
 - 1) burn at a distance above the outlet, or
 - 2) be blown out.

2.1.3 In order to prevent the passage of flame into a cargo tank, devices are to be capable of performing one or more of the following functions:

- a) permitting the gas to pass through passages without flashback and without ignition of the gases on the protected side when the device is subjected to heating for a specified period;
- b) maintaining an efflux velocity in excess of the flame speed for the gas irrespective of the geometric configuration of the device and without the ignition of gases on the protected side, when the device is subjected to heating for a specified period; and
- c) preventing an influx of flame when conditions of vacuum occur within the cargo tanks.

2.2 Mechanical design

2.2.1 The casing or housing of devices is to meet similar standards of strength, heat resistance and corrosion resistance as the pipe to which it is attached.

2.2.2 The design of devices is to allow for ease of inspection and removal of internal elements for replacement, cleaning or repair.

2.2.3 All flat joints of the housing are to be machined true and are to provide an adequate metal-to-metal contact.

2.2.4 Flame arrester elements are to fit in the housing in such a way that flame cannot pass between the element and the housing.

2.2.5 Resilient seals may be installed only if their design is such that if the seals are partially or completely damaged or burned, the device is still capable of effectively preventing the passage of flame.

2.2.6 Devices are to allow for efficient drainage of moisture without impairing their efficiency to prevent the passage of flame.

2.2.7 The casing, flame arrester element and gasket materials are to be capable of withstanding the highest pressure and temperature to which the device may be exposed under both normal and specified fire test conditions.

2.2.8 End-of-line devices are to be so constructed as to direct the efflux vertically upwards.

2.2.9 Fastenings essential to the operation of the device, i.e. screws, etc., are to be protected against loosening.

2.2.10 Means are to be provided to check that any valve lifts easily without remaining in the open position.

2.2.11 Devices in which the flame arresting effect is achieved by the valve function and which are not equipped with flame arrester elements (e.g. high velocity valves) are to have a width of the contact area of the valve seat of at least 5 mm.

2.2.12 Devices are to be resistant to corrosion in accordance with [4.5.1].

2.2.13 Elements, gaskets and seals are to be of material resistant to both seawater and the cargoes carried.

2.2.14 The casing of the housing is to be capable of passing a hydrostatic pressure test, as required in [4.5.2].

2.2.15 In-line devices are to be able to withstand without damage or permanent deformation the internal pressure resulting from detonation when tested in accordance with [4.4].

2.2.16 A flame arrester element is to be designed to ensure quality control of manufacture to meet the characteristics of the prototype tested, in accordance with this Appendix.

2.3 Performance

2.3.1 Devices are to be tested in accordance with [4.5] and thereafter shown to meet the test requirements of [4.2] to [4.4], as appropriate.

Note 1: End-of-line devices which are intended for exclusive use at openings of inerted cargo tanks need not be tested against endurance burning as specified in [4.2.3].

Note 2: Where end-of-line devices are fitted with cowls, weather hoods and deflectors, etc., these attachments are to be fitted for the tests described in [4.2].

Note 3: When venting to atmosphere is not performed through an end-of-line device according to Note 2, or a detonation flame arrester according to [3.2.2], the in-line device is to be specifically tested with the inclusion of all pipes, tees, bends, cowls, weather hoods, etc., which may be fitted between the device and atmosphere. The testing is to consist of the flashback test in [4.2.2] and, if for the given installation it is possible for a stationary flame to rest on the device, the testing is also to include the endurance burning test in [4.2.3].

2.3.2 Performance characteristics such as the flow rates under both positive and negative pressure, operating sensitivity, flow resistance and velocity are to be demonstrated by appropriate tests.

2.3.3 Devices are to be designed and constructed to minimise the effect of fouling under normal operating conditions. Instructions on how to determine when cleaning is required and the method of cleaning are to be provided for each device in the manufacturer's instruction manual.

2.3.4 Devices are to be capable of operating in freezing conditions and if any device is provided with heating arrangements so that its surface temperature exceeds 85°C, then it is to be tested at the highest operating temperature.

2.3.5 Devices based upon maintaining a minimum velocity are to be capable of opening in such a way that a velocity of 30 m/s is immediately initiated, maintaining an efflux velocity of at least 30 m/s at all flow rates and, when the gas flow is interrupted, closing in such a way that this minimum velocity is maintained until the valve is fully closed.

2.3.6 In the case of high velocity vents, the possibility of inadvertent detrimental hammering leading to damage and/or failure is to be considered, with a view to eliminating it.

Note 1: Hammering is intended to mean a rapid full stroke opening/closing, not foreseen by the manufacturer during normal operations.

2.4 Flame screens

2.4.1 Flame screens are to be:

- a) designed in such a manner that they cannot be inserted improperly in the opening
- b) securely fitted in openings so that flames cannot circumvent the screen

- c) able to meet the requirements of this Appendix. For flame screens fitted at vacuum inlets through which vapours cannot be vented, the test specified in [4.2.3] need not be complied with.
- d) protected against mechanical damage.

2.5 Marking of devices

2.5.1 Each device is to be permanently marked, or have a permanently fixed tag made of stainless steel or other corrosion-resistant material, to indicate:

- a) the manufacturer's name or trade mark
- b) the style, type, model or other manufacturer's designation for the device
- c) the size of the outlet for which the device is approved
- d) the approved location for installation, including maximum or minimum length of pipe, if any, between the device and the atmosphere
- e) the direction of flow through the device
- f) the test laboratory and report number, and
- g) compliance with the requirements of this Appendix.

3 Sizing, location and installation of devices

3.1 Sizing of devices

3.1.1 To determine the size of devices to avoid inadmissible pressure or vacuum in cargo tanks during loading or discharging, calculations of pressure losses are to be carried out.

The following parameters are to be taken into account:

- a) loading/discharge rates
- b) gas evolution
- c) pressure loss through devices, taking into account the resistance coefficient
- d) pressure loss in the vent piping system
- e) pressure at which the vent opens if a high velocity valve is used
- f) density of the saturated vapour/air mixture
- g) possible fouling of a flame arrester; 70% of its rated performance is to be used in the pressure drop calculation of the installation.

3.2 Location and installation of devices

3.2.1 General

- a) Devices are to be located at the vent outlets to atmosphere unless tested and approved for in-line installation.
- b) Devices for in-line installation may not be fitted at the outlets to atmosphere unless they have also been tested and approved for that position.

3.2.2 Detonation flame arresters

Where detonation flame arresters are installed as in-line devices venting to atmosphere, they are to be located at a sufficient distance from the open end of the pipeline so as to preclude the possibility of a stationary flame resting on the arrester.

3.2.3 Access to the devices

Means are to be provided to enable personnel to reach devices situated more than 2 m above deck to facilitate maintenance, repair and inspection.

4 Type test procedures

4.1 Principles

4.1.1 Tests are to be conducted by a laboratory acceptable to the Society.

4.1.2 Each size of each model is to be submitted for type testing. However, for flame arresters, testing may be limited to the smallest and the largest sizes and one additional size in between to be chosen by the Society. Devices are to have the same dimensions and most unfavourable clearances expected in the production model. If a test device is modified during the test program, the testing is to be restarted.

4.1.3 Tests described in this Article using gasoline vapours (a non-leaded petroleum distillate consisting essentially of aliphatic hydrocarbon compounds with a boiling range approximating 65°C - 75°C), technical hexane vapours or technical propane, as appropriate, are suitable for all devices protecting tanks containing a flammable atmosphere of the cargoes referred to in [1.1.1]. This does not preclude the use of gasoline vapours or technical hexane vapours for all tests referred to in this Article.

4.1.4 After the relevant tests, the device is not to show mechanical damage that affects its original performance.

4.1.5 Before the tests the following equipment, as appropriate, is to be properly calibrated:

- a) gas concentration meters
- b) thermometers
- c) flow meters
- d) pressure meters, and
- e) time recording devices.

4.1.6 The following characteristics are to be recorded, as appropriate, throughout the tests:

- a) concentration of fuel in the gas mixture
- b) temperature of the test gas mixture at inflow of the device, and
- c) flow rates of the test gas mixtures when applicable.

4.1.7 Flame passage is to be observed by recording, e.g. temperature, pressure, or light emission, by suitable sensors on the protected side of the device; alternatively, flame passage may be recorded on video tape.

4.2 Test procedure for flame arresters located at openings to the atmosphere

4.2.1 Test rig

The test rig is to consist of an apparatus producing an explosive mixture, a small tank with a diaphragm, a flanged prototype of the flame arrester, a plastic bag and a firing source in three positions (see Fig 1). Other test rigs may be used, provided the tests referred to in this Article are carried out to the satisfaction of the Society.

Figure 1 : Test rig for flashback test

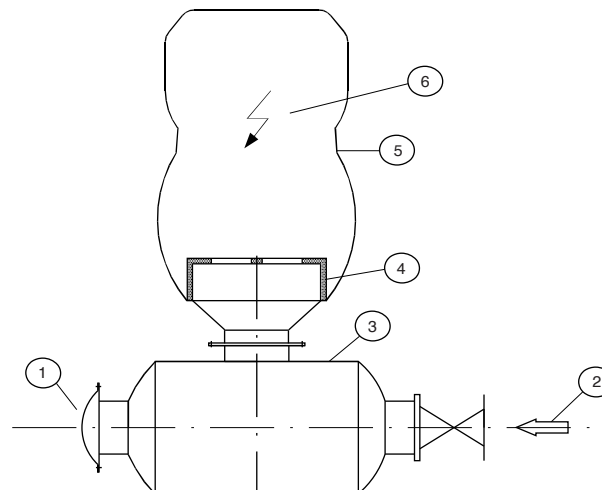

- (1): Plastic bursting diaphragm
- (2): Explosive mixture inlet
- (3): Tank
- (4): Flame arresting device
- (5): Plastic bag
- (6): Ignition source

Note 1: The dimensions of the plastic bag are dependent on those of the flame arrester, but for flame arresters normally used on tankers the plastic bag may have a circumference of 2 m, a length of 2,5 m and a wall thickness of 0,05 mm.

Note 2: In order to avoid remnants of the plastic bag from falling back on to the device being tested after ignition of the fuel/air mixture, it may be useful to mount a coarse wire frame across the device within the plastic bag. The frame is to be so constructed as not to interfere with the test result.

4.2.2 Flashback test

A flashback test is to be carried out as follows:

- The tank, flame arrester assembly and the plastic bag (see [4.2.1]) enveloping the prototype flame arrester are to be filled so that this volume contains the most easily ignitable propane/air mixture (see IEC Publication 79/1).
- If a flashback occurs, the tank diaphragm will burst and this will be audible and visible to the operator by the emission of a flame. Flame, heat and pressure sensors may be used as an alternative to a bursting diaphragm.

The concentration of the mixture is to be verified by appropriate testing of the gas composition in the plastic bag. Where devices referred to in [2.3.1], Note 3 are tested, the plastic bag is to be fitted at the outlet to atmosphere. Three ignition sources are to be installed along the axis of the bag, one close to the flame arrester, another as far away as possible therefrom, and the third at the mid-point between these two. These three sources are to be fired in succession, twice in each of the three positions. The temperature of the test gas is to be within the range of 15°C to 40°C.

Figure 2 : Schematic Plan of the Test Plant for High Velocity Valves (endurance burning test only)

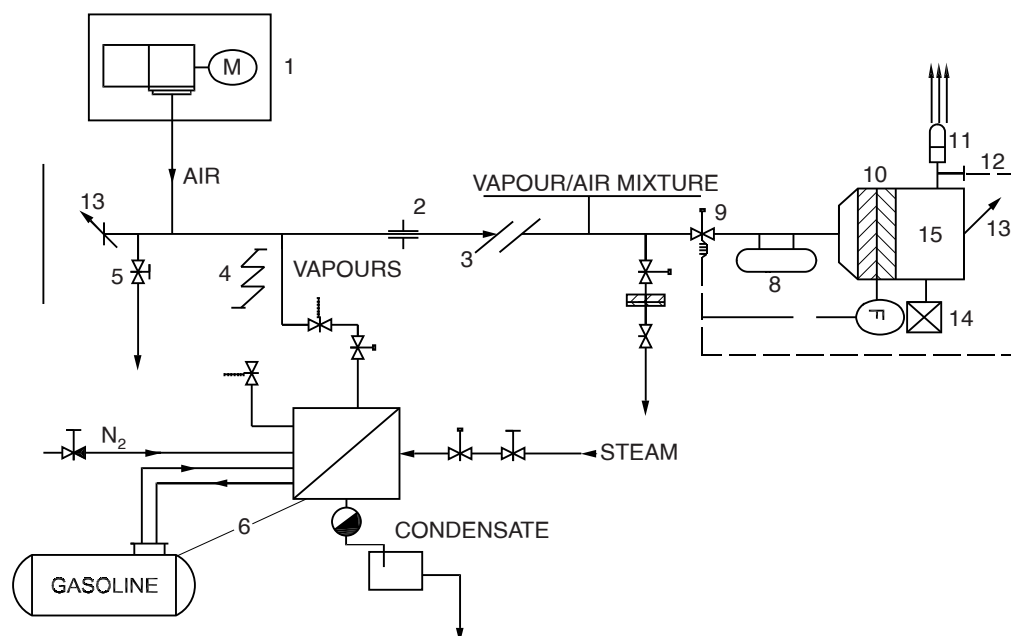

- (1): Fan with variable speed
- (2): Volume rate indicator
- (3): Pipe (diameter=500 mm, length=30 m)
- (4): Heated vapour pipe
- (5): Air bypass
- (6): Evaporator and gasoline storage tank
- (7): Vapour/air mixture bypass
- (8): Extinguishing agents
- (9): Automatic control and quick action stop valve
- (10): Explosion arresting crimped ribbon with temperature sensors for the safety of the test rig
- (11): High velocity valve to be tested
- (12): Flame detector
- (13): Bursting diaphragm
- (14): Concentration indicator
- (15): Tank

4.2.3 Endurance burning test

An endurance burning test is to be carried out, in addition to the flashback test, for flame arresters at outlets where flows of explosive vapour are foreseeable:

- The test rig as referred to in [4.2.1] may be used, without the plastic bag. The flame arrester is to be so installed that the mixture emission is vertical. In this position the mixture is to be ignited. Where devices referred to in [2.3.1], Note 3, are tested, the flame arrester is to be so installed as to reflect its final orientation.
- Endurance burning is to be achieved by using the most easily ignitable gasoline vapour/air mixture or the most easily ignitable technical hexane vapour/air mixture with the aid of a continuously operated pilot flame or a continuously operated spark igniter at the outlet. The test gas is to be introduced upstream of the tank shown in Fig 1. Maintaining the concentration of the mixture as specified above, by varying the flow rate, the flame arrester is to be heated until the highest obtainable temperature on the cargo tank side of the arrester is reached. Temperatures are to be measured, for example, at the protected side of the flame quenching matrix of the arrester (or at the seat of the valve in the case of testing high velocity vents according to [4.3]). The highest

obtainable temperature may be considered to have been reached when the rate of rise of temperature does not exceed 0,5°C per minute over a ten-minute period. This temperature is to be maintained for a period of ten minutes, after which the flow is to be stopped and the conditions observed. The temperature of the test gas is to be within the range of 15°C to 40°C.

If no temperature rise occurs at all, the arrester is to be inspected for a more adequate position of the temperature sensor, taking account of the visually registered position of the stabilised flame during the first test sequence. Positions which require the drilling of small holes into fixed parts of the arrester are to be taken into account. If all this is not successful, the temperature sensor is to be affixed at the unprotected side of the arrester in a position near to the stabilised flame.

If difficulties arise in establishing stationary temperature conditions (at elevated temperatures), the following criterion is to apply: using the flow rate which produced the maximum temperature during the foregoing test sequence, endurance burning is to be continued for a period of two hours from the time the above-mentioned flow rate has been established. After that period the flow is to be stopped and the conditions observed. Flashback is not to occur during this test.

Figure 3 : Test Rig for High Velocity Vents

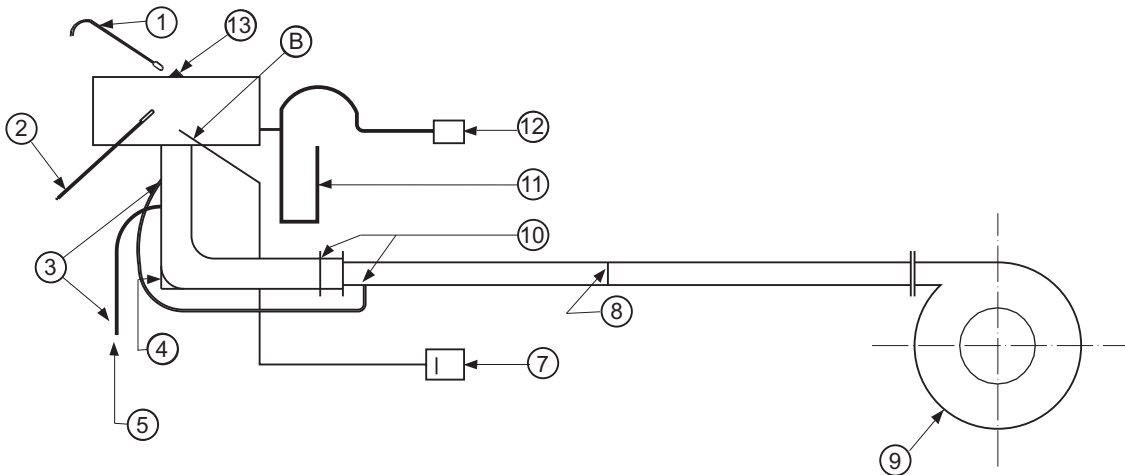

- (1): Primary igniter
- (2): Secondary igniter
- (3): Cocks
- (4): Explosion door
- (5): Gas supply
- (6): Flashback detector
- (7): Chart recorder
- (8): Flow meter
- (9): Fan
- (10): Spade blank and bypass line for low rates
- (11): Pressure gauge
- (12): Gas analyser
- (13): High velocity vent to be tested

4.2.4 Pressure/vacuum valve integrated to a flame arresting device

When a pressure/vacuum valve is integrated to a flame arresting device, the flashback test is to be performed with the pressure/ vacuum valve blocked open. If there are no additional flame quenching elements integrated in a pressure valve, this valve is to be considered and tested as a high velocity vent valve according to [4.3].

4.3 Test procedures for high velocity vents

4.3.1 Test rig

The test rig is to be capable of producing the required volume flow rate. In Fig 2 and Fig 3 drawings of suitable test rigs are shown. Other test rigs may be used provided the tests are performed to the satisfaction of the Society.

4.3.2 Flow condition test

A flow condition test is to be carried out with high velocity vents using compressed air or gas at agreed flow rates. The following are to be recorded:

- the flow rate; where air or a gas other than vapours of cargoes with which the vent is to be used is employed in the test, the flow rates achieved are to be corrected to reflect the vapour density of such cargoes
- the pressure before the vent opens; the pressure in the test tank on which the device is located is not to rise at a rate greater than 0,01 MPa/min
- the pressure at which the vent opens
- the pressure at which the vent closes
- the efflux velocity at the outlet which is not to be less than 30 m/s at any time when the valve is open.

4.3.3 Fire safety tests

The following fire safety tests are to be conducted while adhering to [2.3.6] using a mixture of gasoline vapour and air or technical hexane vapour and air, which produces the most easily ignitable mixture at the point of ignition. This mixture is to be ignited with the aid of a permanent pilot flame or a spark igniter at the outlet.

- Flashback tests in which propane may be used instead of gasoline or hexane are to be carried out with the vent in the upright position and then inclined at 10° from the vertical. For some vent designs further tests with the vent inclined in more than one direction may be necessary. In each of these tests the flow is to be reduced until the vent closes and the flame is extinguished, and each is to be carried out at least 50 times. The vacuum side of combined valves is to be tested in accordance with [4.2.2] with the vacuum valve maintained in the open position for the duration of this test, in order to verify the efficiency of the device which is to be fitted.
- An endurance burning test, as described in [4.2.3], is to be carried out. Following this test, the main flame is to be extinguished and then, with the pilot flame burning or the spark igniter discharging, small quantities of the most easily ignitable mixture are to be allowed to escape for a period of ten minutes maintaining a pres-

sure below the valve of 90% of the valve opening setting, during which time flashback is not to occur. For the purpose of this test the soft seals or seats are to be removed.

4.4 Test rig and test procedures for detonation flame arresters located in-line

4.4.1 A flame arrester is to be installed at one end of a pipe of suitable length and of the same diameter as the flange of the flame arrester. On the opposed flange a pipe of a length corresponding to 10 pipe diameters is to be affixed and closed by a plastic bag or diaphragm. The pipe is to be filled with the most easily ignitable mixture of propane and air, which is then to be ignited. The velocity of the flame near the flame arrester is to be measured and is to have the same value as that for stable detonations.

Note 1: The dimensions of the plastic bag are to be at least 4 m circumference, 4 m length and a material wall thickness of 0,05 mm.

4.4.2 Three detonation tests are to be conducted, no flashback is to occur through the device and no part of the flame arrester is to be damaged or show permanent deformation.

4.4.3 Other test rigs may be used provided the tests are carried out to the satisfaction of the Society. A drawing of the test rig is shown in Fig 4.

4.5 Operational test procedure

4.5.1 Corrosion test

A corrosion test is to be carried out. In this test a complete device, including a section of the pipe to which it is fitted, is to be exposed to a 5% sodium chloride solution spray at a temperature of 25°C for a period of 240 hours, and allowed to dry for 48 hours. An equivalent test may be conducted to the satisfaction of the Society. Following this test, all movable parts are to operate properly and there are to be no corrosion deposits which cannot be washed off.

4.5.2 Hydraulic pressure test

A hydraulic pressure test is to be carried out in the casing or housing of a sample device, in accordance with [2.2.15].

4.6 Laboratory report

4.6.1 The laboratory report is to include:

- detailed drawings of the device
- types of tests conducted; where in-line devices are tested, this information is to include the maximum pressures and velocities observed in the test
- specific advice on approved attachments
- types of cargo for which the device is approved
- drawings of the test rig
- in the case of high velocity vents, the pressures at which the device opens and closes and the efflux velocity, and
- all the information marked on the device in [2.5].

Figure 4 : Test Rig for Arresters Located In-Line

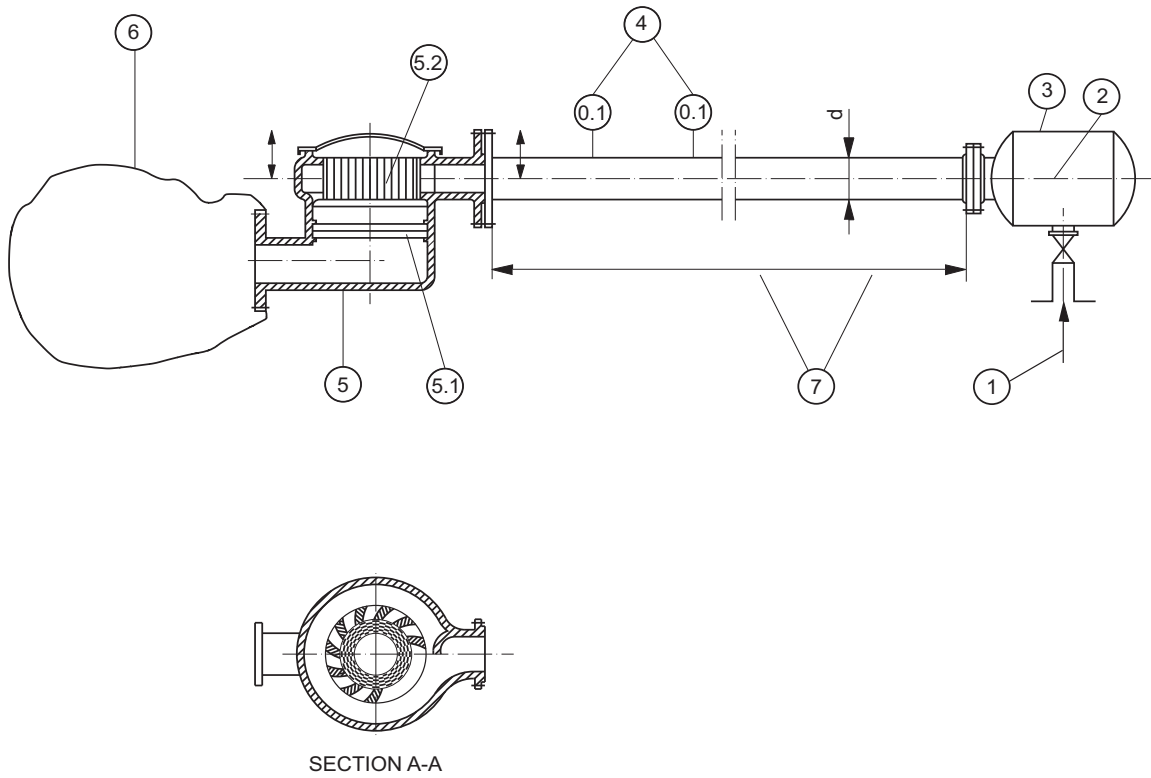

- (1): Explosive mixture inlet
- (2): Ignition source; ignition within non-streaming mixture
- (3): Tank
- (4): Measuring system for flame speed of a stable detonation
- (5): Flame arrester located in-line; (5.1): Flame arrester element; (5.2): Shock wave absorber
- (6): Plastic bag
- (7): $l/d = 100$

APPENDIX 2

DESIGN OF CRUDE OIL WASHING SYSTEMS

1 General

1.1 Application

1.1.1 This Appendix applies to FSO provided with crude oil washing system for cargo tank cleaning.

2 Design and installation

2.1 Piping

2.1.1 The crude oil washing pipes and all valves incorporated in the supply piping system are to be of steel or other equivalent material, of adequate strength having regard to the pressure to which they may be subjected, and properly jointed and supported.

Note 1: Grey cast iron may be permitted in the supply system for crude oil washing systems when complying with nationally approved standards.

The crude oil washing system is to consist of permanent pipework and is to be independent of the fire mains and of any system other than for tank washing except that sections of the unit's cargo system may be incorporated into the crude oil washing system provided that they meet the requirements applicable to crude oil pipework.

2.1.2 Provisions are to be made to prevent overpressure in the tank washing supply piping. Any relief device fitted to prevent overpressure is to discharge into the suction side of the supply pump. Alternative methods to the satisfaction of the Society may be accepted provided an equivalent degree of safety and environmental protection is provided.

Note 1: Where the system is served only by centrifugal pumps so designed that the pressure derived cannot exceed that for which the piping is designed, a temperature sensing device located in the pump casing is required to stop the pump in the case of overheating.

2.1.3 Where hydrant valves are fitted for water washing purposes on tank washing lines, all such valves are to be of adequate strength and provisions are to be made for such connections to be blanked off by blank flanges when washing lines may contain crude oil. Alternatively, hydrant valves are to be isolated from the crude oil washing system by spade blanks.

2.1.4 All connections for pressure gauges or other instrumentation are to be provided with isolating valves adjacent to the lines unless the fitting is of the sealed type.

2.1.5 No part of the crude oil washing system is to enter machinery spaces. Where the tank washing system is fitted with a steam heater for use when water washing, the heater

is to be located outside machinery spaces and effectively isolated during crude oil washing by double shut-off valves or by clearly identifiable blanks.

2.1.6 Where combined crude oil-water washing supply piping is provided, the piping is to be so designed that it can be drained so far as practicable of crude oil, before water washing is commenced, into designated spaces. These spaces may be the slop tank or other cargo spaces.

2.1.7 The crude oil washing supply piping is to be anchored (firmly attached) to the unit's structure at appropriate locations, and means are to be provided to permit freedom of movement elsewhere to accommodate thermal expansion and flexing of the unit. The anchoring is to be such that any hydraulic shock can be absorbed without undue movement of the supply piping. The anchors are normally to be situated at the ends furthest from the entry of the crude oil supply to the supply piping. If tank washing machines are used to anchor the ends of branch pipes then special arrangements are necessary to anchor these sections when the machines are removed for any reason.

2.2 Tank washing machines

2.2.1 Tank washing machines for crude oil washing are to be permanently mounted and of a design acceptable to the Society. Where a machine is positioned well below the deck level to cater for protuberances in the tank, consideration may need to be given to additional support for the machine and its supply piping.

2.2.2 Each machine is to be capable of being isolated by means of stop valves in the supply line. If a deck mounted tank washing machine is removed for any reason, provision is to be made to blank off the oil supply line to the machine for the period the machine is removed. Similarly, provision is to be made to close the tank opening with a plate or equivalent means.

2.3 Pumps

2.3.1 Pumps supplying crude oil to tank cleaning machines are to be either the cargo pumps or pumps specifically provided for the purpose.

2.4 Ballast lines

2.4.1 Where a separate ballast water system for ballasting cargo tanks is not provided, the arrangement is to be such that the cargo pump, manifolds and pipes used for ballasting can be safely and effectively drained of oil before ballasting.

3 Testing

3.1 Piping

3.1.1 The crude oil washing piping system is to be tested at one and half time the design pressure after it has been installed on the unit.

SECTION 1	GENERAL
SECTION 2	UNIT ARRANGEMENT
SECTION 3	HULL AND STABILITY
SECTION 4	MACHINERY AND SYSTEMS IN CARGO AREA
SECTION 5	ELECTRICAL INSTALLATIONS
SECTION 6	SAFETY SYSTEMS
SECTION 7	FIRE PROTECTION, DETECTION AND EXTINCTION
APPENDIX 1	DEVICES TO PREVENT THE PASSAGE OF FLAME INTO THE CARGO TANKS
APPENDIX 2	DESIGN OF CRUDE OIL WASHING SYSTEMS

SECTION 1

GENERAL

1 General

1.1 Application

1.1.1 Units complying with the requirements of this Chapter are eligible for the assignment of the service notation **FPSO**, as defined in Pt A, Ch 1, Sec 2, [4.3.1].

1.1.2 Units dealt with in this Chapter are to comply with the requirements stipulated in Part A, Part B, Part C and Part D, as applicable and with the requirements of this Chapter, which are specific to floating units intended for the production, storage and off-loading of liquid hydrocarbons.

1.2 Summary table

1.2.1 Tab 1 indicates, for easy reference, the Sections of this Chapter dealing with requirements applicable to units having the notation **FPSO**.

Table 1

Main subject	Reference
Ship arrangement	Sec 2
Hull and stability	Sec 3
Machinery	Sec 4
Electrical installations	Sec 5
Automation	(1)
Fire protection, detection and extinction	Sec 6
(1) No specific requirements for FPSO are given in this Chapter.	

SECTION 2

UNIT ARRANGEMENT

1 General arrangement design

1.1 General

1.1.1 Cargo segregation

Unless expressly provided otherwise, tanks containing cargo or cargo residues are to be segregated from accommodation, service and machinery spaces, drinking water and stores for human consumption by means of a cofferdam of width not less than 760 mm, or any other similar compartment.

Where accommodation and service compartments are arranged immediately above the compartments containing flammable liquids, the cofferdam may be omitted only where the deck is not provided with access openings and is coated with a layer of material recognised as suitable by the Society. The cofferdam may also be omitted where such compartments are adjacent to a passageway, subject to the following conditions:

- the thicknesses of common boundary plates of adjacent tanks are increased, with respect to those obtained from the applicable requirements in Part B and Sec 3, by 2 mm in the case of tanks carrying fresh water or boiler feed water, and by 1 mm in all other cases
- the sum of the throats of the weld fillets at the edges of such plates is not less than the thickness of the plates themselves
- the hydrostatic test is carried out with a head increased by 1 m with respect to that required in Pt B, Ch 12, Sec 3 of the Rules for the Classification of Ships.

1.1.2 Deck spills

Means are to be provided to keep deck spills away from the accommodation and service areas. This may be accomplished by providing a permanent continuous coaming of a suitable height extending from side to side.

Where gutter bars are installed on the weather decks in way of cargo manifolds and are extended aft as far as the aft bulkhead of superstructures for the purpose of containing cargo spills on deck during loading and discharge operations, the free surface effects caused by containment of a cargo spill during liquid transfer operations or of boarding seas while underway are to be considered with respect to the vessel's available margin of positive initial stability (GM_0).

On units without deck camber, or where the height of the installed gutter bars exceeds the camber, and for units having cargo tanks exceeding 60% of the unit's maximum beam amidships regardless of gutter bar height, gutter bars may not be accepted without an assessment of the initial stability (GM_0) for compliance with the relevant intact stability requirements taking into account the free surface effect caused by liquids contained by the gutter bars.

2 Access arrangement

2.1 General

2.1.1 As far as practicable, permanent or movable means of access stored on board are to be provided to ensure proper survey and maintenance of cargo tanks and ballast compartments.

2.1.2 Means of access to side and centre tanks may not be provided in the same transverse section.

2.2 Access to pipe tunnel and opening arrangement

2.2.1 Access to the pipe tunnel in the double bottom

The pipe tunnel in the double bottom is to comply with the following requirements:

- it may not communicate with the engine room
- provision is to be made for at least two exits to the open deck arranged at a maximum distance from each other. One of these exits fitted with a watertight closure may lead to the cargo pump room.

2.2.2 Doors between pipe tunnel and main pump room

Where there is a permanent access from a pipe tunnel to the main pump room, a watertight door is to be fitted complying with the requirements in Pt B, Ch 2, Sec 1, [2.2.1] for watertight doors open at sea and located below the free-board deck. In addition the following is to be complied with:

- in addition to bridge operation, the watertight door is to be capable of being manually closed from outside the main pump room entrance
- the watertight door is to be kept closed during normal operations of the unit except when access to the pipe tunnel is required. A notice is to be affixed to the door to the effect that it may not be left open.

2.3 Access to compartments in the cargo area

2.3.1 General

Access to cofferdams, ballast tanks, cargo tanks and other compartments in the cargo area is to be direct from the open deck and such as to ensure their complete inspection. Access to double bottom compartments may be through a cargo pump room, pump room, deep cofferdam, pipe tunnel or similar compartments, subject to consideration of ventilation aspects.

2.3.2 Access to the fore peak tank

The access to the fore peak tank is to be direct from the open deck.

Alternatively, indirect access from the open deck to the fore peak tank through an enclosed space may be accepted provided that:

- a) if the enclosed space is separated from the cargo tanks by cofferdams, the access is through a gas-tight bolted manhole located in the enclosed space and a warning sign is provided at the manhole stating that the fore peak tank may only be opened after:
 - it has been proven to be gas-free; or
 - any electrical equipment which is not electrically certified safe in the enclosed space is isolated
- b) if the enclosed space has a common boundary with the cargo tanks and is therefore hazardous, the enclosed space can be well ventilated.

2.3.3 Access through horizontal openings

For access through horizontal openings the dimensions are to be sufficient to allow a person wearing a self-contained, air-breathing apparatus and protective equipment to ascend or descend any ladder without obstruction and also to pro-

vide a clear opening to facilitate the hoisting of an injured person from the bottom of the compartment. The minimum clear opening is to be not less than 600 mm by 600 mm.

2.3.4 Access through vertical openings

For access through vertical openings the minimum clear opening is to be not less than 600 mm by 800 mm at a height of not more than 600 mm from the bottom shell plating unless gratings or other footholds are provided.

2.4 Access to the bow

2.4.1 FPSO units are to be provided either with a gangway between the superstructure or deckhouse aft and the fore-castle, or with equivalent arrangements in accordance with the International Load Line Convention 1966, as amended.

2.4.2 FPSO units are to be provided with the means to enable the crew to gain safe access to the bow even in severe weather conditions. Such means are to be accepted by the Society.

Note 1: The Society considers means in compliance with the Guidelines adopted by the Maritime Safety Committee of IMO with Resolution MSC.62(67) on 5/12/1996 as being acceptable.

SECTION 3

HULL AND STABILITY

Symbols

- R_y : Minimum yield stress, in N/mm², of the material, to be taken equal to 235/k N/mm², unless otherwise specified
- k : Material factor for steel, defined in Pt B, Ch 4, Sec 1, [2.3] of the Rules for the Classification of Ships
- E : Young's modulus, in N/mm², to be taken equal to:
- $E = 2,06 \cdot 10^5$ N/mm² for steels in general
 - $E = 1,95 \cdot 10^5$ N/mm² for stainless steels.

1 General

1.1

1.1.1 This Section applies in addition to the requirements set out in Part B.

2 Intact stability

2.1 General requirements

2.1.1 In each loading condition the following is to be satisfied:

- a) the initial metacentric height, calculated by taking into account the influence of the free surfaces, is to be not less than 0,15 m
- b) the diagrams of the stability arms are to confirm the following requisites:
 - 1) the arm of maximum stability Gz_{max} is to correspond to a transverse heeling angle preferably greater than 30° but in any case not less than 25°;
 - 2) the arm of stability GZ is to be not less than 0,20 m with a transverse heeling angle θ not less than 30°;
 - 3) the area below the stability diagram is to be not less than 0,055 m·rad for heeling angles θ from 0° to 30° and not less than 0,09 m·rad for heeling angles θ from 0° to 40° or to θ_i if the latter is less than 40°.

The heeling angle θ_i is that which corresponds to the intake of water and therefore defines where the stability curve is to be considered broken.

In addition to the above, the area below the stability diagram is to be not less than 0,030 m·rad, for heeling angles from 30° to 40° or from 30° to θ_i , if θ_i is less than 40°

- c) the provisions of the following paragraphs are to be checked in relation to the action of the wind.

2.2 Liquid transfer operation

2.2.1 Units with certain internal subdivision may be subjected to lolling during liquid transfer operations such as loading, unloading or ballasting. In order to prevent the effect of lolling, the unit's design is to be such that the following criteria are complied with:

- a) the intact stability criteria reported in b) is to be complied with for the worst possible condition of loading and ballasting as defined in c), consistent with good operational practice, including the intermediate stages of liquid transfer operations. Under all conditions the ballast tanks are to be assumed slack;
- b) the initial metacentric height GMo , in m, corrected for free surface measured at 0°heel, is to be not less than 0,15. For the purpose of calculating GMo , liquid surface corrections are to be based on the appropriate upright free surface inertia moment;
- c) the unit is to be loaded with:
 - all cargo tanks filled to a level corresponding to the maximum combined total of vertical moment of volume plus free surface inertia moment at 0°heel, for each individual tank
 - cargo density corresponding to the available cargo deadweight at the displacement at which transverse KM reaches a minimum value
 - full consumable
 - 1% of the total water ballast capacity. The maximum free surface moment is to be assumed in all ballast tanks.

2.3 Weather criterion

2.3.1 The curves are to be traced of the righting and heeling moments due to the transverse wind similar to those shown in Fig 1, together with the relevant calculations, taking into account the maximum cargo on the deck and the equipment placed in the most unfavourable position.

The effect of the free surfaces in the tanks is to be taken into account.

2.3.2 If there are structural fittings which can be dismantled and stowed, further curves of the heeling moment due to the wind may be requested and the relevant documentation is to clearly indicate the position of these fittings.

2.3.3 When calculating the righting moment, any possible negative effects due to the presence of the mooring system are to be taken into account.

2.3.4 As regards the calculation of the forces and heeling moment due to the wind, reference is made to the relevant provisions of Ch 4, Sec 3, [3.1].

In particular, for the wind speed, the characteristic value of the site corresponding to a recurring period of 100 years or the speed of 51,5 m/s (100 knots) is to be assumed, whichever is the greater.

For sites situated in protected zones, the Society reserves the right to accept a wind speed less than 51,5 m/s.

2.3.5 The stability of a unit is to satisfy the criteria stated under the following items (a) and (b) (see also Fig 1):

- a) The ratio of the area under the righting moment curve to that under the heeling moment curve up to the angle in way of the second intercept or up to the downflooding angle θ_f , whichever is the lesser, is to be not less than 1,4.
- b) The righting moment curve is to be positive over the entire range of angles up to the angle in way of the second intercept.

2.3.6 Each unit should be capable of attaining a severe storm condition in a period of time consistent with the meteorological conditions. The procedures recommended and the approximate length of time required, considering both operating conditions and transit conditions, should be contained in the Operating Manual.

It should be possible to achieve the severe storm condition without the removal or relocation of solid consumables or other variable load. However, the Society may permit loading a unit past the point at which solid consumables would have to be removed or relocated to attain the severe storm condition under the following conditions, provided the allowable KG requirement is not exceeded:

- a) in a geographic location where weather conditions annually or seasonally do not become sufficiently severe to require a unit to go to severe storm conditions, or
- b) where a unit is required to support extra deckload for a short period of time that falls well within a period for which the weather forecast is favourable.

The geographic locations, weather conditions and loading conditions in which this is permitted should be identified in the Operating Manual.

2.4 Alternative stability criteria

2.4.1 Alternative stability criteria may be considered by the Society provided an equivalent level of safety is maintained and it is demonstrated that they afford adequate positive initial stability.

3 Closing appliances

3.1 General requirements

3.1.1 Closing appliances are to comply with the applicable requirements of the International Convention on Load Line in force.

4 Watertight integrity

4.1

4.1.1 The number of openings in the watertight bulkheads is to be kept to a minimum compatible with the design and proper working of the unit.

4.1.2 Where it is necessary to penetrate the watertight bulkheads for access or piping, ventilation, electrical cables etc., arrangements are to be made to maintain the watertight integrity of the enclosed compartments.

4.1.3 When the watertight boundaries are provided with valves to maintain watertight integrity, it is to be possible to operate these valves from a pump room or other normally manned space, an open deck or a deck situated above the bulkhead deck.

4.1.4 Valve position indicators are to be provided in the remote control room.

5 Freeboard

5.1

5.1.1 Classification of the unit presupposes that all the applicable requirements and provisions contained in the International Convention on Load Line in force are complied with.

Figure 1 : Righting moment and heeling moment curves

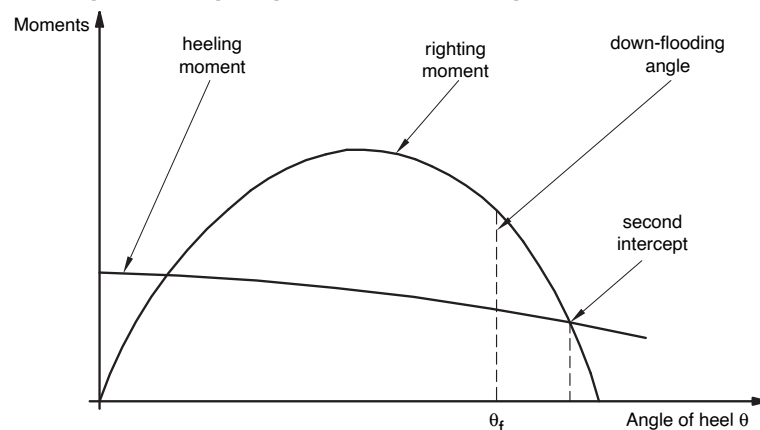

6 Structure design principles

6.1 Framing arrangement

6.1.1 In general, within the cargo tank region, the bottom, the inner bottom and the deck are to be longitudinally framed.

Different framing arrangements are to be considered by the Society on a case-by-case basis, provided that they are supported by direct calculations.

6.2 Bulkhead structural arrangement

6.2.1 General

Transverse bulkheads may be either plane or corrugated.

6.2.2 Corrugated bulkheads

For units of less than 120 m in length, vertically corrugated transverse or longitudinal bulkheads may be connected to the double bottom and deck plating.

For units equal to or greater than 120 m in length, a lower and an upper stool are generally to be fitted. Different arrangements may be considered by the Society on a case-by-case basis, provided that they are supported by direct calculations carried out according to Pt B, Ch 7, Sec 3 of the Rules for the Classification of Ships. These calculations are to investigate, in particular, the zones of connection of the bulkhead with inner bottom and deck plating and are to be submitted to the Society for review.

7 Design loads

7.1 Hull girder loads

7.1.1 Still water loads

In addition to the requirements in Pt B, Ch 5, Sec 2, [2.1.2], still water loads are to be calculated for the following loading conditions, subdivided on-site operations and transit conditions and, where applicable, into departure and arrival conditions as appropriate:

- homogeneous loading conditions (excluding tanks intended exclusively for segregated ballast tanks) at maximum draft
- partial loading conditions
- any specified non-homogeneous loading condition
- light and heavy ballast conditions
- conditions relating to tank cleaning or other operations where, at the Society's discretion, these differ significantly from the ballast conditions.

7.2 Local loads

7.2.1 Cargo mass density

In the absence of more precise values, a cargo mass density of 0,9 t/m³ is to be considered for calculating the internal pressures and forces in cargo tanks according to Pt B, Ch 5, Sec 6.

8 Hull scantlings

8.1 Plating

8.1.1 Minimum net thicknesses

The net thickness of the strength deck and bulkhead plating within or bounding the longitudinal extension of the cargo area is to be not less than the values given in Tab 1.

8.2 Ordinary stiffeners

8.2.1 Minimum net thicknesses

The net thickness of the web of ordinary stiffeners is to be not less than the value obtained, in mm, from the following formulae:

$$t_{\text{MIN}} = 0,75 L^{1/3} k^{1/6} + 4,5 s \quad \text{for } L < 275 \text{ m}$$

$$t_{\text{MIN}} = 1,5 k^{1/2} + 7,0 + s \quad \text{for } L \geq 275 \text{ m}$$

where s is the spacing, in m, of ordinary stiffeners.

8.3 Primary supporting members

8.3.1 Minimum net thicknesses

The net thickness of plating which forms the webs of primary supporting members is to be not less than the value obtained, in mm, from the following formula:

$$t_{\text{MIN}} = 1,45 L^{1/3} k^{1/6}$$

8.3.2 Loading conditions for the analyses of primary supporting members

The still water and wave loads are to be calculated for the most severe loading conditions as given in the loading manual, with a view to maximising the stresses in the longitudinal structure and primary supporting members.

Where the loading manual is not available, the loading conditions to be considered in the analysis of primary supporting members in cargo and ballast tanks are those shown in:

- Fig 1 for units less than 200 m in length
- Fig 2 and Fig 3 for units equal to or greater than 200 m in length.

Table 1 : Minimum net thickness of the strength deck and bulkhead plating

Plating	Minimum net thickness, in mm	
Strength deck	$(5,5 + 0,02 L) k^{1/2}$	for L < 200
	$(8 + 0,0085 L) k^{1/2}$	for L ≥ 200
Tank bulkhead	$L^{1/3} k^{1/6} + 4,5 s$	for L < 275
	$1,5 k^{1/2} + 8,2 + s$	for L ≥ 275
Watertight bulkhead	$0,85 L^{1/3} k^{1/6} + 4,5 s$	for L < 275
	$1,5 k^{1/2} + 7,5 + s$	for L ≥ 275
Wash bulkhead	$0,8 + 0,013 L k^{1/2} + 4,5 s$	for L < 275
	$3,0 k^{1/2} + 4,5 + s$	for L ≥ 275
Note 1: s : Length, in m, of the shorter side of the plate panel.		

Figure 2 : Loading conditions for units less than 200 m in length

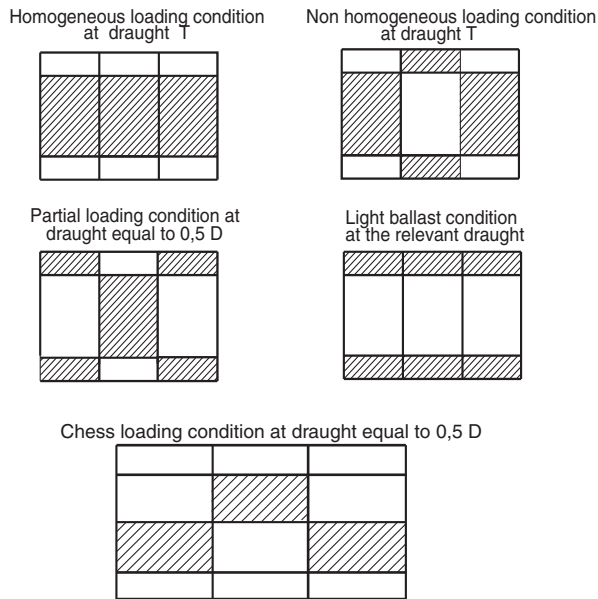

8.3.3 Strength check of floors of cargo tank structure with hopper tank analysed through a three dimensional beam model

Where the cargo tank structure with hopper tank is analysed through a three dimensional beam model, to be carried out according to Pt B, Ch 7, App 1 of the Rules for the Classification of Ships, the net shear sectional area of floors within $0,1 \ell$ from the floor ends (see Fig 4 for the definition of ℓ) is to be not less than the value obtained, in cm^2 , from the following formula:

$$A_{sh} = 2 \frac{Q}{\gamma_R \gamma_m R_y}$$

where:

Q : Shear force, in kN, in the floors at the ends of ℓ , obtained from the structural analysis

γ_R : Resistance partial safety factor:

$$\gamma_R = 1,2$$

γ_m : Material partial safety factor:

$$\gamma_m = 1,02$$

Figure 3 : Loading conditions for units equal to or greater than 200 m in length

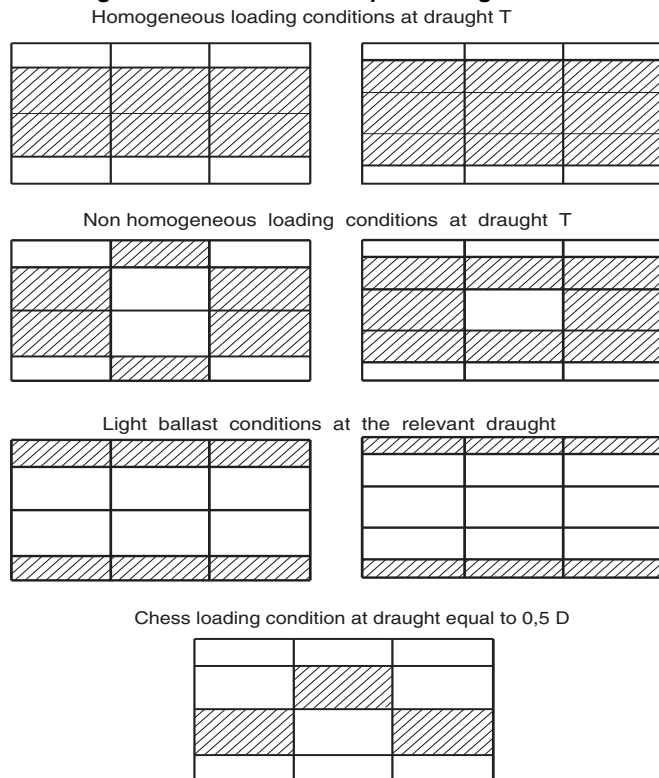
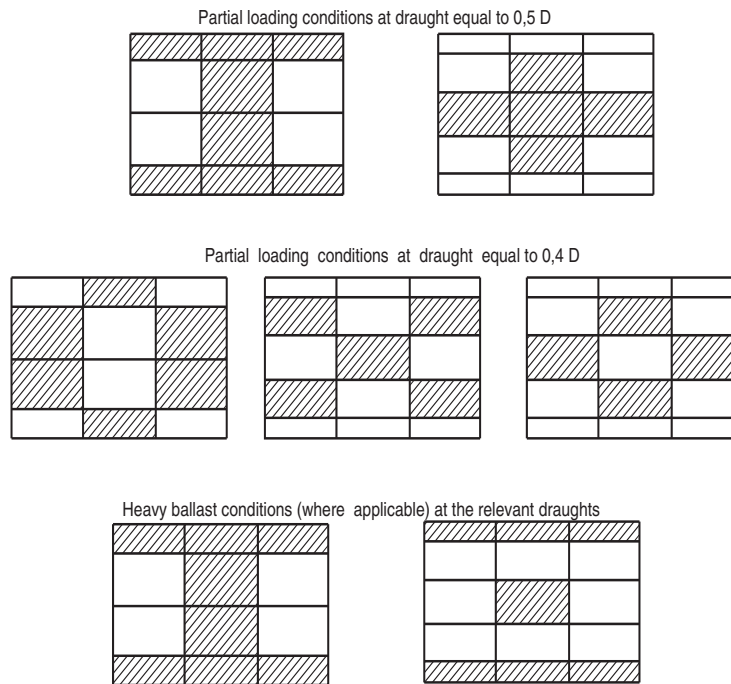

Figure 4 : Loading conditions for units equal to or greater than 200 m in length



8.3.4 Strength checks of cross-ties analysed through a three dimensional beam model

a) Cross-ties analysed through three dimensional beam model analyses according to Pt B, Ch 7, Sec 3 of the Rules for the Classification of Ships are to be considered, in the most general case, as being subjected to axial forces and bending moments around the neutral axis perpendicular to the cross-tie web. This axis is identified as the y axis, while the x axis is that in the web plane (see Figures in Tab 2).

The axial force may be either tensile or compression. Depending on this, two types of checks are to be carried out, according to b) or c), respectively.

b) Strength check of cross-ties subjected to axial tensile forces and bending moments.

The net scantlings of cross-ties are to comply with the following formula:

$$10 \frac{F_T}{A_{ct}} + 10^3 \frac{M}{W_{yy}} \leq \frac{R_y}{\gamma_R \gamma_m}$$

where:

- F_T : Axial tensile force, in kN, in the cross-ties, obtained from the structural analysis
- A_{ct} : Net sectional area, in cm^2 , of the cross-tie
- M : Max ($|M_1|$, $|M_2|$)
- M_1, M_2 : Algebraic bending moments, in kN.m, around the y axis at the ends of the cross-tie, obtained from the structural analysis
- w_{yy} : Net section modulus, in cm^3 , of the cross-tie about the y axis
- γ_R : Resistance partial safety factor:
 $\gamma_R = 1,02$

γ_m : Material partial safety factor:
 $\gamma_m = 1,02$

c) Strength check of cross-ties subjected to axial compressive forces and bending moments.

The net scantlings of cross-ties are to comply with the following formulae:

$$10 F_C \left(\frac{1}{A_{ct}} + \frac{\Phi e}{w_{xx}} \right) \leq \frac{R_y}{\gamma_R \gamma_m}$$

$$10 \frac{F_C}{A_{ct}} + 10^3 \frac{M_{max}}{w_{yy}} \leq \frac{R_y}{\gamma_R \gamma_m}$$

where:

- F_C : Axial compressive force, in kN, in the cross-ties, obtained from the structural analysis
- A_{ct} : Net cross-sectional area, in cm^2 , of the cross-tie

$$\Phi = \frac{1}{1 - \frac{F_C}{F_{EX}}}$$

F_{EX} : Euler load, in kN, for buckling around the x axis:

$$F_{EX} = \frac{\pi^2 E I_{xx}}{10^5 \ell^2}$$

- I_{xx} : Net moment of inertia, in cm^4 , of the cross-tie about the x axis
- ℓ : Span, in m, of the cross-tie
- e : Distance, in cm, from the centre of gravity to the web of the cross-tie, specified in Tab 2 for various types of profiles
- w_{ww} : Net section modulus, in cm^3 , of the cross-tie about the x axis

M_{\max} : Max ($|M_0|$, $|M_1|$, $|M_2|$)

$$M_0 = \frac{\sqrt{1+t^2}(M_1+M_2)}{2 \cos(u)}$$

$$t = \frac{1}{\tan(u)} \left(\frac{M_2 - M_1}{M_2 + M_1} \right)$$

$$u = \frac{\pi}{2} \sqrt{\frac{F_C}{F_{EY}}}$$

F_{EY} : Euler load, in kN, for buckling around the y axis:

$$F_{EY} = \frac{\pi^2 EI_{yy}}{10^5 \ell^2}$$

I_{yy} : Net moment of inertia, in cm^4 , of the cross-tie about the y axis

M_1, M_2 : Algebraic bending moments, in kN.m , around the y axis at the ends of the cross-tie, obtained from the structural analysis

w_{yy} : Net section modulus, in cm^3 , of the cross-tie about the y axis

γ_R : Resistance partial safety factor:

$$\gamma_R = 1,02$$

γ_m : Material partial safety factor:

$$\gamma_m = 1,02$$

Figure 5 : End area of floors

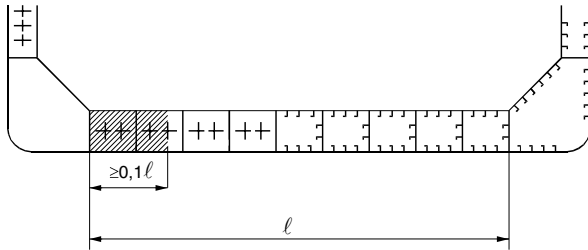

8.3.5 Strength checks of cross-ties analysed through a three dimensional finite element model

- a) In addition to the requirements in Pt B, Ch 7, Sec 3, [4] and Pt B, Ch 7, Sec 3, [6] of the Rules for the Classification of Ships, the net scantlings of cross-ties subjected to compression axial stresses are to comply with the following formula:

$$|\sigma| \leq \frac{\sigma_c}{\gamma_R \gamma_m}$$

where:

σ : Compressive stress, in N/mm^2 , obtained from a three dimensional finite element analysis, based on fine mesh modelling, according to Pt B, Ch 7, Sec 3 and Pt B, Ch 7, App 1 of the Rules for the Classification of Ships

σ_c : Critical stress, in N/mm^2 , defined in b)

γ_R : Resistance partial safety factor:

$$\gamma_R = 1,02$$

γ_m : Material partial safety factor:

$$\gamma_m = 1,02$$

- b) The critical buckling stress of cross-ties is to be obtained, in N/mm^2 , from the following formulae:

$$\sigma_c = \sigma_E \quad \text{for } \sigma_E \leq \frac{R_y}{2}$$

$$\sigma_c = R_y \left(1 - \frac{R_y}{4\sigma_E} \right) \quad \text{for } \sigma_E > \frac{R_y}{2}$$

where:

$$\sigma_E = \min(\sigma_{E1}, \sigma_{E2}),$$

σ_{E1} : Euler flexural buckling stress, to be obtained, in N/mm^2 , from the following formula:

$$\sigma_{E1} = \frac{\pi^2 EI}{10^4 A_{ct} \ell^2}$$

I : Min (I_{xx} , I_{yy})

I_{xx} : Net moment of inertia, in cm^4 , of the cross-tie about the x axis defined in Ch 1, Sec 3, [8.3.4] a)

I_{yy} : Net moment of inertia, in cm^4 , of the cross-tie about the y axis defined in Ch 1, Sec 3, [8.3.4] a)

A_{ct} : Net cross-sectional area, in cm^2 , of the cross-tie

ℓ : Span, in m, of the cross-tie

σ_{E2} : Euler torsional buckling stress, to be obtained, in N/mm^2 , from the following formula:

$$\sigma_{E2} = \frac{\pi^2 EI_w}{10^4 I_o \ell^2} + 0,41 E \frac{J}{I_o}$$

I_w : Net sectorial moment of inertia, in cm^4 , of the cross-tie, specified in Tab 2 for various types of profiles

I_o : Net polar moment of inertia, in cm^4 , of the cross-tie

$$I_o = I_{xx} + I_{yy} + A_{ct}(y_o + e)^2$$

y_o : Distance, in cm, from the centre of torsion to the web of the cross-tie, specified in Tab 2 for various types of profiles

e : Distance, in cm, from the centre of gravity to the web of the cross-tie, specified in Tab 2 for various types of profiles,

J : St. Venant's net moment of inertia, in cm^4 , of the cross-tie, specified in Tab 2 for various types of profiles.

8.4 Strength check with respect to stresses due to the temperature gradient

8.4.1 Direct calculations of stresses induced in the hull structures by the temperature gradient are to be performed for units intended to carry cargoes at temperatures exceeding 75°C . In these calculations, the water temperature is to be assumed equal to 0°C .

The calculations are to be submitted to the Society for review.

8.4.2 The stresses induced in the hull structures by the temperature gradient are to comply with the checking criteria in Pt B, Ch 7, Sec 3, [4.3] of the Rules for the Classification of Ships.

9 Other structures

9.1 Opening arrangement

9.1.1 Tanks covers

Covers fitted on all cargo tank openings are to be of sturdy construction, and to ensure tightness for hydrocarbon and water.

Aluminium is not permitted for the construction of tank covers. The use of reinforced fibreglass covers is to be specially examined by the Society.

Table 2 : Calculation of cross-tie geometric properties

Cross-tie profile	e	y_0	J	I_w
<p>T symmetrical</p>	0	0	$\frac{1}{3}(2b_f t_f^3 + h_w t_w^3)$	$\frac{t_f h_w^2 b_f^3}{24}$

Cross-tie profile	e	y ₀	J	I _w
<p>T non-symmetrical</p>	0	0	$\frac{1}{3} (b_{1f} + b_{2f})t_f^3 + h_w t_w^3 $	$\frac{t_f h_w^3 b_{1f}^3 b_{2f}^3}{12 (b_{1f}^3 + b_{2f}^3)}$
<p>Non-symmetrical</p>	$\frac{b^2 t_f}{h t_w + 2 b t_f}$	$\frac{3 b^2 t_f}{6 b_f t_f + h_w t_w}$	$\frac{1}{3} (2 b_f t_f^3 + h_w t_w^3)$	$\frac{t_f b_f^3 h^2 3 b_f t_f + 2 h_w t_w}{12 6 b_f t_f + h_w t_w}$

10 Construction and testing

10.1 Welding and weld connections

10.1.1 The welding factors for some hull structural connections are specified in Tab 3. These welding factors are to

be used, in lieu of the corresponding factors specified in Pt B, Ch 13, Sec 1, Tab 2, to calculate the throat thickness of fillet weld T connections according to Pt B, Ch 13, Sec 1, [2.3]. For the connections of Tab 3, continuous fillet welding is to be adopted.

Table 3 : Welding factor w_F

Hull area	Connection		Welding factor w _F
	of	to	
Double bottom in way of cargo tanks	girders	bottom and inner bottom plating	0,35
		floors (interrupted girders)	0,35
	floors	bottom and inner bottom plating	0,35
		inner bottom in way of bulkheads or their lower stools	0,45
		girders (interrupted floors)	0,35
Bulkheads (1)	ordinary stiffeners	bulkhead plating	0,35

(1) Not required to be applied to units with the additional service feature **flashpoint > 60°C**.

SECTION 4

MACHINERY AND SYSTEMS IN CARGO AREA

1 General

1.1 Application

1.1.1 The requirements of this section apply to the venting system, purging and/or gas-freeing system, level gauging systems, protection against overload system, washing systems and heating system of cargo tanks as well as to bilge

and ballast systems, to air, sounding pipes and scuppers in cargo area.

The requirements for cargo handling systems and production, process and supports systems are given in Part C, Chapter 5 and Part C, Chapter 6.

1.2 Documentation to be submitted

1.2.1 Tab 1 lists the plans, information, analysis, etc. which are to be submitted in addition to the information required in the other Parts of the Rules.

Table 1 : Documents to be submitted

No	(1)	Documents (2)
1	A	Diagram of the oil cargo tank venting system with: <ul style="list-style-type: none"> • indication of the outlet position • details of the pressure/vacuum valves and flame arrestors • details of the draining arrangements, if any
2	A	Diagram of the oil cargo tank level gauging system with overfill safety arrangements
3	A	Diagram of the oil cargo tank heating system
4	A	Oil cargo tank cleaning system
5	A	Gas freeing system of cargo tanks
6	A	Diagram of bilge system in cargo area
7	A	Diagram of ballast systems in cargo area
8	A	Diagram of air, sounding and scuppers in cargo area
(1) A = to be submitted for approval in four copies		
(2) Diagrams are also to include, where applicable, the (local and remote) control and monitoring systems and automation systems		

1.2.2 The information listed in Tab 2 is also to be submitted.

Table 2 : Informations to be submitted

No	(1)	Documents (1)
1	A	Material, external diameter and wall thickness of the pipes
2	A	Type of the connections between pipe lengths, including details of the weldings, where provided
3	A	Material, type and size of the accessories
4	A	For plastic pipes: <ul style="list-style-type: none"> • the chemical composition • the physical and mechanical characteristics in function of temperature • the characteristics of inflammability and fire resistance • the resistance to the products intended to be conveyed
(1) A = to be submitted for approval in four copies		

2 Cargo tank venting systems

2.1 Principle

2.1.1 Cargo tanks are to be provided with venting systems entirely distinct from the air pipes of the other compartments of the unit. The arrangements and position of openings in the cargo tank deck from which emission of flammable vapours can occur are to be such as to minimise the possibility of flammable vapours being admitted to enclosed spaces containing a source of ignition, or collecting in the vicinity of deck machinery and equipment which may constitute an ignition hazard.

2.1.2 Design of venting arrangements

The venting arrangements are to be so designed and operated as to ensure that neither pressure nor vacuum in cargo tanks exceeds design parameters and be such as to provide for:

- the flow of the small volumes of vapour, air or inert gas mixtures caused by thermal variations in an cargo tank in all cases through pressure/vacuum valves, and
- the passage of large volumes of vapour, air or inert gas mixtures during oil loading and ballasting, or during discharging,
- a secondary means of allowing full flow relief of vapour, air or inert gas mixtures to prevent overpressure or under pressure in the event of failure of the arrangements in b).

Alternatively, pressure sensors may be fitted in each tank protected by the arrangement required in b), with a monitoring system in the unit's oil handling control room or the position from which oil handling operations are normally carried out. Such monitoring equipment is also to provide an alarm facility which is activated by detection of overpressure or under pressure conditions within a tank.

2.1.3 Combination of venting arrangements

- The venting arrangements in each cargo tank may be independent or combined with other cargo tanks and may be incorporated into the inert gas piping.
- Where the arrangements are combined with other cargo tanks, either stop valves or other acceptable means are to be provided to isolate each cargo tank. Where stop valves are fitted, they are to be provided with locking arrangements which are to be under the control of the responsible unit's officer. There is to be a clear visual indication of the operational status of the valves or other acceptable means. Where tanks have been isolated, it is to be ensured that relevant isolating valves are opened before oil loading or ballasting or discharging of those tanks is commenced. Any isolation must continue to permit the flow caused by thermal variations in an cargo tank in accordance with [2.1.2] a).
- If oil loading and ballasting or discharging of an cargo tank or cargo tank group is intended, which is isolated from a common venting system, that cargo tank or cargo tank group is to be fitted with a means for overpressure or under pressure protection as required in [2.1.2] c).

2.1.4 Arrangement of vent lines

The venting arrangements are to be connected to the top of each cargo tank and are to be self-draining to the cargo tanks under all normal conditions of trim and list of the unit.

Where it may not be possible to provide self-draining lines, permanent arrangements are to be provided to drain the vent lines to an cargo tank.

Plugs or equivalent means are to be provided on the lines after the safety relief valves.

2.1.5 Openings for pressure release

Openings for pressure release required by [2.1.2] a) are to:

- have as great a height as is practicable above the cargo tank deck to obtain maximum dispersal of flammable vapours but in no case less than 2 m above the cargo tank deck,
- be arranged at the furthest distance practicable but not less than 5 m from the nearest air intakes and openings to enclosed spaces containing a source of ignition and from deck machinery and equipment which may constitute an ignition hazard. Anchor windlass and chain locker openings constitute an ignition hazard.

2.1.6 Pressure/vacuum valves

- One or more pressure/vacuum-breaking devices are to be provided to prevent the cargo tanks from being subject to:
 - a positive pressure, in excess of the test pressure of the cargo tank, if the oil were to be loaded at the maximum rated capacity and all other outlets were left shut; and
 - a negative pressure in excess of 700 mm water gauge if oil were to be discharged at the maximum rated capacity of the oil pumps and the inert gas blowers were to fail.

Such devices are to be installed on the inert gas main unless they are installed in the venting system required by [2] or on individual cargo tanks.
- Pressure/vacuum valves are to be set at a positive pressure not exceeding 0,021 MPa and at a negative pressure not exceeding 0,007 MPa. Higher setting values not exceeding 0,07 MPa may be accepted in positive pressure if the scantlings of the tanks are appropriate.
- Pressure/vacuum valves required by [2.1.2] a) may be provided with a bypass when they are located in a vent main or masthead riser. Where such an arrangement is provided, there are to be suitable indicators to show whether the bypass is open or closed.
- Pressure/vacuum valves are to be of a type approved by the Society in accordance with App 1.
- Pressure/vacuum valves are to be readily accessible.
- Pressure/vacuum valves are to be provided with a manual opening device so that valves can be locked on open position. Locking means on closed position are not permitted.

2.1.7 Vent outlets

Vent outlets for cargo loading, discharging and ballasting required by [2.1.2] b) are to:

- a) permit:
- 1) the free flow of vapour mixtures, or
 - 2) the throttling of the discharge of the vapour mixtures to achieve a velocity of not less than 30 m/s,
- b) Pressure/vacuum valves are to be set at a positive pressure not exceeding 0,021 MPa and at a negative pressure not exceeding 0,007 MPa. Higher setting values not exceeding 0,07 MPa may be accepted in positive pressure if the scantlings of the tanks are appropriate.
- c) where the method is by free flow of vapour mixtures, be such that the outlet is not less than 6 m above the cargo tank deck or fore and aft gangway if situated within 4 m of the gangway and located not less than 10 m measured horizontally from the nearest air intakes and openings to enclosed spaces containing a source of ignition and from deck machinery which may include anchor windlass and chain locker openings, and equipment which may constitute an ignition hazard,
- d) where the method is by high velocity discharge, be located at a height not less than 2 m above the cargo tank deck and not less than 10 m measured horizontally from the nearest air intakes and openings to enclosed spaces containing a source of ignition and from deck machinery which may include anchor windlass and chain locker openings, and equipment which may constitute an ignition hazard. These outlets are to be provided with high velocity devices of a type approved by the Society,
- e) be designed on the basis of the maximum designed loading rate multiplied by a factor of at least 1,25 to take account of gas evolution, in order to prevent the pressure in any oil tank from exceeding the design pressure.

The Master is to be provided with information regarding the maximum permissible loading rate for each cargo tank and in the case of combined venting systems, for each group of cargo tanks,

- f) the arrangements for the venting of vapours displaced from the cargo tanks during loading and ballasting are to comply with [2] and are to consist of either one or more mast risers, or a number of high-velocity vents. The inert gas supply main may be used for such venting.

2.1.8 High velocity valves

- a) High velocity valves are to be readily accessible.
- b) High velocity valves not required to be fitted with flame arresters (see [2.1.9]) are not to be capable of being locked on open position.

2.1.9 Prevention of the passage of flame into the tanks

- a) The venting system is to be provided with devices to prevent the passage of flame into the cargo tanks. The design, testing and locating of these devices are to comply with App 1.

Ullage openings are not to be used for pressure equalisation.

They are to be provided with self-closing and tightly sealing covers. Flame arresters and screens are not permitted in these openings.

- b) A flame arresting device integral to the venting system may be accepted.
- c) Flame screens and flame arresters are to be designed for easy overhauling and cleaning.

2.1.10 Prevention of liquid rising in the venting system

- a) Provisions are to be made to prevent liquid rising in the venting system; refer to article [5].
- b) Cargo tanks gas venting systems are not to be used for overflow purposes.
- c) Spill valves are not considered equivalent to an overflow system.

3 Cargo tank purging and/or gas-freeing

3.1 General

3.1.1 Arrangements are to be made for purging and/or gas freeing of cargo tanks. The arrangements are to be such as to minimise the hazards due to the dispersal of flammable vapours in the atmosphere and to flammable mixtures in a cargo tank.

In the case of fans installed in safe spaces, two non return devices are to be fitted to avoid return of oil vapours to safe spaces when the ventilation system is shut down. These non-return devices are to operate in all normal conditions of unit trim and list.

Discharge outlets are to be located at least 10 m measured horizontally from the nearest air intake and openings to enclosed spaces with a source of ignition and from deck machinery equipment which may constitute an ignition hazard.

The cargo tanks are first to be purged in accordance with the provisions of Sec 7, [8] until the concentration of hydrocarbon vapours in the oil tanks has been reduced to less than 2% by volume. Thereafter, gas-freeing may take place at the cargo tank deck level.

4 Cargo tank level gauging systems

4.1 General

4.1.1 Each cargo or slop tank is to be fitted with a level gauging system indicating the liquid level along the entire height of the tank.

Gauging devices and their remote reading systems are to be type approved.

The gauging devices are to be of the closed type.

A "closed type gauging device" means a device which is separated from the tank atmosphere and keeps tank contents from being released. It may:

- penetrate the tank, such as float-type systems, electric probe, magnetic probe or protected sight glass,
- not penetrate the tank, such as ultrasonic or radar devices.

Use of indirect gauging devices will be given special consideration.

An "indirect gauging device" means a device which determines the level of liquid, for instance by means of weighing or pipe flow meter .

5 Protection against tank overload

5.1 General

5.1.1 The following requirements are to be complied with:

- a) Provisions are to be made to guard against liquid rising in the venting system of cargo or slop tanks to a height which would exceed the design head of the tanks. This is to be accomplished by high level alarms or overflow control systems or other equivalent means, together with gauging devices and cargo tank filling procedures.
- b) Sufficient ullage is to be left at the end of tank filling to permit free expansion of liquid during carriage.
- c) High level alarms, overflow control systems and other means referred to in a) are to be independent of the gauging systems referred to in [4].

5.1.2 High level alarms

- a) High level alarms are to be type approved.
- b) High level alarms are to give an audible and visual signal at the control station, where provided.

5.1.3 Other protection systems

- a) Where the tank level gauging systems, oil and ballast pump control systems and valve control systems are centralised in a single location, the provisions of [5.1.1] may be complied with by the fitting of a level gauge for the indication of the end of loading, in addition to that required for each tank in [4]. The readings of both gauges for each tank are to be as near as possible to each other and so arranged that any discrepancy between them can be easily detected.
- b) Where a tank can be filled only from other tanks, the provisions of [5.1.1] are considered as complied with.

6 Tank washing systems

6.1 General

6.1.1 Adequate means are to be provided for cleaning the cargo tanks.

Crude oil washing systems are to comply with the provisions of App 2 which are related to safety only.

6.1.2 Washing machines

Washing machines are to be made of steel or other electricity conducting materials with a limited propensity to produce sparks on contact.

6.1.3 Washing pipes

- a) Washing pipes are to be built, fitted, inspected and tested in accordance with the applicable requirements of Pt C, Ch 1, Sec 10 of the Rules for the Classification of Ships, depending on the kind of washing fluid, water or crude oil.
- b) Crude oil washing pipes are also to satisfy the requirements of Pt C, Ch 5, Sec 2.

6.1.4 Use of crude oil washing machines for water washing operations

Crude oil washing machines may be connected to water washing pipes, provided that isolating arrangements, such as a valve and a detachable pipe section, are fitted to isolate water pipes.

6.1.5 Installation of washing systems

- a) Tank cleaning openings are not to be arranged in enclosed spaces.
- b) The complete installation is to be permanently earthed to the hull.

7 Heating systems intended for cargo tanks and other users in cargo area

7.1 General

7.1.1 The following general requirements apply:

- a) Heating systems intended for cargo are to comply with the relevant requirements of Pt C, Ch 1, Sec 10 of the Rules for the Classification of Ships
- b) The steam and heating media temperature within the cargo area is not to exceed 220° C.
- c) Blind flanges or similar devices are to be provided on the heating circuits fitted to tanks containing cargoes which are not to be heated.
- d) Heating systems are to be so designed that the pressure maintained in the heating circuits is higher than that exerted by the cargo oil. This need not be applied to heating circuits which are not in service provided they are drained and blanked-off.
- e) Isolating valves are to be provided at the inlet and outlet connections of the tank heating circuits. Arrangements are to be made to allow manual adjustment of the flow.
- f) Heating pipes and coils inside tanks are to be built of a material suitable for the heated fluid. They are to have welded connections only.

7.1.2 Steam heating

To reduce the risk of liquid or vapour cargo returns inside the engine or boiler rooms, steam heating systems of cargo tanks are to satisfy either of the following provisions:

- a) they are to be independent of other unit services, except cargo heating or cooling systems, and are not to enter machinery spaces, or
- b) they are to be provided with an observation tank on the water return system located within the cargo area. However, this tank may be placed inside the engine room in a well-ventilated position remote from boilers and other sources of ignition. Its air pipe is to be led to the open and fitted with a flame arrester.

7.1.3 Hot water heating

Hot water systems serving cargo tanks are to be independent of other systems. They are not to enter machinery spaces unless the expansion tank is fitted with:

- a) means for detection of flammable vapours
- b) a vent pipe led to the open and provided with a flame arrester.

7.1.4 Thermal oil heating

Thermal oil heating systems serving cargo tanks are to be arranged by means of a separate secondary system, located completely within the cargo area. However, a single circuit system may be accepted provided that:

- a) the system is so arranged as to ensure a positive pressure in the coil of at least 3 m water column above the static head of the cargo when the circulating pump is not in operation
- b) means are provided in the expansion tank for detection of flammable cargo vapours. Portable equipment may be accepted
- c) valves for the individual heating coils are provided with a locking arrangement to ensure that the coils are under static pressure at all times.

8 Bilge system in cargo area

8.1 General

8.1.1 The requirements of this Article apply to bilge systems in cargo area. In addition the applicable requirements for piping systems in Pt C, Ch 1, Sec 10 of the Rules for the Classification of Ships are to be applied.

Bilge systems serving spaces located within the cargo area:

- are to be independent from any piping system serving spaces located outside the cargo area
- are not to lead outside the cargo area.

8.2 Drainage of cofferdams and void spaces located within cargo area

8.2.1 Cofferdams and void spaces located within the cargo area and not intended to be filled with water ballast are to be fitted with suitable means of drainage.

8.3 Drainage of cofferdams located at the fore and aft ends of cargo tanks

8.3.1

- a) When they are not intended to be filled with water ballast, cofferdams located at the fore and aft ends of the cargo tanks are to be fitted with drainage arrangements.
- b) Aft cofferdams adjacent to the cargo pump room may be drained by a cargo pump in accordance with the provisions of [8.4.1] b) and c), or by bilge ejectors.
- c) Cofferdams located at the fore end of the cargo tanks are to be drained by one or more power pumps fitted in a suitable space forward of cargo tanks or by bilge ejectors.
- d) Drainage of the after cofferdam from the engine room bilge system is not permitted.

8.4 Drainage of pump rooms

8.4.1

- a) Arrangements are to be provided to drain the pump rooms by means of power pumps or bilge ejectors.
- b) Cargo pumps or stripping pumps may be used for draining cargo pump rooms provided that:
 - a screw-down non-return valve is fitted on the bilge suction, and
 - a remote control valve is fitted between the pump suction and the bilge distribution box.
- c) Bilge pipe internal diameter is not to be less than 50 mm.
- d) The bilge system of cargo pump rooms is to be capable of being controlled from outside.
- e) High liquid level in the bilges is to activate an audible and visual alarm in the cargo control room and on the navigation bridge.

8.5 Drainage of tunnels and pump rooms other than cargo pump rooms

8.5.1 Arrangements are to be provided to drain tunnels and pump rooms other than cargo pump rooms. Cargo pumps may be used for this service under the provisions of [8.4.1] b).

Bilge suction pipes to tunnel wells are not to be less than 65 mm in diameter.

9 Ballast system in cargo area

9.1 General

9.1.1 The requirements of this Article apply to ballast systems in cargo area. In addition the applicable requirements for piping systems in Pt C, Ch 1, Sec 10 of the Rules for the Classification of Ships apply.

Unless otherwise specified ballast systems serving spaces located within the cargo area:

- are to be independent from any piping system serving spaces located outside the cargo area;
- are not to lead outside the cargo area;
- are to be completely separated from the cargo oil and fuel oil systems.

9.2 Pumping arrangement for ballast tanks within cargo area

9.2.1 Ballast tanks located within the cargo area are to be served by two different means. At least one of these means is to be a pump or an eductor used exclusively for dealing with ballast.

Ballast pumps are to be located in the cargo pump room, or a similar space within the cargo area not containing any source of ignition.

Where installed in the cargo pump room the relevant prime movers are to be located outside the cargo pump room, except in the following cases:

- steam driven machine supplied with steam having a temperature not exceeding 220 °C
- hydraulic motors
- electric motors of certified type.

Where ballast pumps are driven by a machine which is located in a non hazardous area outside the cargo pump room, the following arrangements are to be made:

- drive shafts are to be fitted with flexible couplings or other means suitable to compensate for any misalignment
- the shaft bulkhead or deck penetration is to be fitted with a gas-tight gland of a type approved by the Society.

The gland is to be efficiently lubricated from outside the oil handling pump room and so designed as to prevent overheating. The seal parts of the gland are to be of material that cannot initiate sparks.

- temperature sensing devices are to be fitted for bulkhead shaft gland bearings and pump casing.

9.3 Emergency discharge of ballast

9.3.1 Provisions may be made for emergency discharge of the ballast by means of a connection to a cargo pump through a detachable spool piece provided that:

- non-return valves are fitted on the ballast connections to prevent the passage of oil to the ballast tank, and
- shut-off valves are fitted to shut off the cargo and ballast lines before the spool piece is removed.

The detachable spool piece is to be placed in a conspicuous position in the pump room and a permanent warning notice restricting its use is to be displayed in a conspicuous position adjacent to it.

9.4 Ballast water in cargo tanks

9.4.1

- Provisions are to be made for filling cargo tanks with sea water, where permitted
- The sea water inlets and overboard discharges serving cargo tanks for the purpose of a) are not to have any connection with the ballast system of ballast tanks.
- Cargo pumps may be used for pumping ballast water to or from the cargo tanks, provided two shut-off valves are fitted to isolate the cargo piping system from the sea inlets and overboard discharges.
- Ballast pumps serving ballast tanks may be used for filling the cargo tanks with sea water provided that the connection is made on the top of the tanks and consists of a detachable spool piece and a screw-down non-return valve to avoid siphon effects.

9.5 Pumping arrangement for cofferdams located at the fore and aft ends of the cargo tanks

9.5.1 Where they are intended to be filled with water ballast, the cofferdams located at the fore and aft ends of the cargo tanks may be emptied by a ballast pump located inside the machinery compartment or a forward space, whichever is the case, provided that:

- the suction is directly connected to the pump and not to a piping system serving machinery spaces
- the delivery is directly connected to the unit side.

9.6 Ballast systems for fore peak

9.6.1 The fore peak tank can be ballasted with the system serving ballast tanks within the cargo area, provided:

- the fore peak tank is considered hazardous
- the vent pipe openings are located on open deck 3 m away from sources of ignition
- means are provided, on the open deck, to allow measurement of flammable gas concentrations within the fore peak tank by a suitable portable instrument
- the sounding arrangement to the fore peak tank is direct from open deck.

9.7 Ballast pipes passing through tanks

9.7.1

- a) Ballast piping is not to pass through cargo tanks except in the case of short lengths of piping complying with the following:
- they are to have welded or heavy flanged joints the number of which is kept to a minimum
 - they are to be of extra-reinforced wall thickness as per Pt C, Ch 1, Sec 10, Tab 5 of the Rules for the Classification of Ships
 - they are to be adequately supported and protected against mechanical damage.
- b) sliding type couplings are not to be used for expansion purposes where ballast lines pass through cargo tanks. Expansion bends only are permitted.

10 Air and sounding pipes of spaces other than cargo tanks in cargo area

10.1 General

10.1.1 The air and sounding pipes fitted to the following spaces:

- cofferdams located at the fore and aft ends of the cargo tanks
- tanks and cofferdams located within the cargo area and not intended for cargo are to be led to the open.

10.2 Air pipes

10.2.1 The air pipes referred to in [10.1.1] are to be arranged as per Pt C, Ch 1, Sec 10, [9] of the Rules for the Classification of Ships and are to be fitted with easily removable flame screens at their outlets.

10.3 Passage through cargo tanks

10.3.1 The air and sounding pipes referred to in [10.1.1] are not to pass through cargo tanks except in the following cases:

- short lengths of piping serving ballast tanks
- lines serving double bottom tanks located within the cargo area

provided that the following provisions are complied with:

- they are to have welded or heavy flanged joints the number of which is kept to a minimum
- they are to be of extra-reinforced wall thickness as per Pt C, Ch 1, Sec 10, Tab 5 of the Rules for the Classification of Ships
- they are to be adequately supported.

11 Scupper pipes in cargo area

11.1

11.1.1 Scupper pipes are not to pass through cargo tanks except, where this is impracticable, in the case of short lengths of piping complying with the following provisions:

- they are of steel
- they have welded or heavy flanged joints the number of which is kept to a minimum
- they are of substantial wall thickness as per Pt C, Ch 1, Sec 10, Tab 23, column 1 of the Rules for the Classification of Ships.

12 Certification, inspection and testing

12.1 Application

12.1.1 The provisions of this Article are related to the venting system, purging and/or gas-freeing system, level gauging systems, protection against overload system, washing systems and heating system of cargo tanks as well as to bilge and ballast systems, air pipes, sounding pipes and scuppers in cargo area.

They supplement those given in Pt C, Ch 5, Sec 2, [7] for oil handling piping systems and Pt C, Ch 6, Sec 2, [11] for production and process systems.

12.2 Workshop tests

12.2.1 Tests for materials

Where required in Tab 3, materials used for pipes, valves and fittings are to be subjected to the tests specified in Pt C, Ch 1, Sec 10, [21.3.2] of the Rules for the Classification of Ships.

12.2.2 Inspection of welded joints

Where required in Tab 3 welded joints are to be subjected to the examinations specified in Pt C, Ch 1, Sec 10, [3.6] of the Rules for the Classification of Ships.

12.2.3 Hydrostatic testing

- a) Where required in Tab 3, pipes, valves and fittings are to be submitted to hydrostatic tests in accordance with the relevant provisions of Pt C, Ch 1, Sec 10, [21.4] of the Rules for the Classification of Ships.
- b) Expansion joints are to be submitted to hydrostatic tests in accordance with the relevant provisions of Pt C, Ch 1, Sec 10, [21.4] of the Rules for the Classification of Ships.

12.2.4 Tightness tests

Tightness of the following devices is to be checked:

- cargo tank P/V and high velocity valves.

Note 1: These tests may be carried out in the workshops or on board.

12.2.5 Check of the safety valves setting

The setting pressure of the pressure/vacuum valves is to be checked in particular with regard to [2.1.6].

12.2.6 Summarising table

Inspections and tests required for venting system, purging and/or gas-freeing system, level gauging system, protection against overload system, washing system and heating system of cargo tanks as well as for bilge and ballast systems and for air, sounding and scuppers in cargo area are summarised in Tab 3.

12.3 Shipboard tests

12.3.1 Pressure test

- After installation on board, the piping systems are to be checked for leakage under operational conditions.
- Heating oils in cargo tanks are to be tested to not less than 1,5 times the design pressure but in no case less than 0,4 MPa
- The piping system used in crude oil washing systems is to be submitted to hydrostatic tests in accordance with App 2, [3.1.1].

12.3.2 Functional tests

The overall performance of the venting system, purging and/or gas-freeing system, level gauging system, protection against overload system, washing system and heating system of cargo tanks as well as bilge and ballast systems are to be verified for compliance with the design parameters during the initial unit operations. Records of the performance of the components and equipment essential to verify the design parameters are to be maintained and be available to the Society.

Table 3 : Inspection and testing at works

No	Item	Test of materials		Inspections and tests for the products			References
		Y/N (1)	Type of material certificate (2)	during Manufacturing (1)	after completion (1) (3)	Type of product certificate (2)	
1	Cargo tank P/V and high velocity valves	Y	C	Y	Y	C	[12.2.1] [12.2.2] (4) [12.2.3] [12.2.4] [12.2.5]
2	flame arresters	N		N	Y	C	(3)

(1) Y = required, N = not required.
(2) C = class certificate
(3) includes the checking of the rule characteristics according to the approved drawings.
(4) Only in the case if welded construction

SECTION 5

ELECTRICAL INSTALLATIONS

1 General

1.1 Application

1.1.1 The requirements in this Section apply to FPSO units in addition to those contained in Part C, Chapter 2.

1.2 Documentation to be submitted

1.2.1 In addition to the documentation requested in Pt C, Ch 2, Sec 1, Tab 1 of the Rules for the Classification of Ships, the following are to be submitted for approval:

- a) plan of hazardous areas
- b) document giving details of types of cables and safety characteristics of the equipment installed in hazardous areas
- c) diagrams of tank level indicator systems, high level alarm systems and overflow control systems where requested.
- d) diagram of emergency shutdown circuits
- e) cause and effect diagram.

1.3 Definitions

1.3.1 Source of release: point or location from which a flammable gas, vapour, or liquid may be released into the atmosphere in such a way that an explosive gas atmosphere could be formed.

1.3.2 Grades of release: there are three basic grades of release, as listed below in order of decreasing frequency and likelihood of the explosive gas atmosphere being present:

- a) continuous grade;
- b) primary grade;
- c) secondary grade.

A source of release may give rise to any one of these grades of release, or to a combination of more than one.

1.3.3 Continuous grade of release: release which is continuous or is expected to occur frequently or for long periods.

1.3.4 Primary grade of release: release which can be expected to occur periodically or occasionally during normal operation.

1.3.5 Secondary grade of release: release which is not expected to occur in normal operation and, if it does occur, is likely to do so only infrequently and for short periods.

1.3.6 Release rate: quantity of flammable gas or vapour emitted per unit time from the source of release.

1.4 Monitoring of circuit in hazardous areas

1.4.1 The device intended to continuously monitor the insulation level of all distribution system are also to monitor all circuits, other than intrinsically safe circuits, connected to apparatus in hazardous areas or passing through such areas.

An audible and visual alarm is to be given, at a manned position, in the event of an abnormally low level of insulation.

Systems fed by single transformers supplying one consumer or a control circuit do not require an earth fault detection.

1.5 Precautions against inlet of gases or vapours

1.5.1 Suitable arrangements are to be provided, to the satisfaction of the Society, so as to prevent the possibility of gases or vapours passing from a gas-dangerous space to another space through runs of cables or their conduits.

2 Hazardous location classification and permitted electrical equipment

2.1 General

2.1.1 Units are to be assessed with regard to any potential explosive gas atmosphere in accordance with the provisions of [2] or alternatively with an acceptable Code or Standard giving equivalent safety.

2.1.2 The results are to be documented in area classification drawings to allow the proper selection of all electrical components to be installed.

2.1.3 The hazardous location classification is to be carried out by those who have knowledge of the properties of flammable materials, the process and the equipment, in consultation with, as appropriate, safety, electrical, mechanical and other engineering personnel.

2.1.4 Classification of hazardous areas in ZONES is defined in Pt C, Ch 2, Sec 1, [3.24] of the Rules for the Classification of Ships.

2.1.5 Release as a result of accidental events such as blow-out or vessel rupture is not addressed by area classification. It is to be covered by emergency measures.

2.1.6 Openings, penetrations or connections between areas of different hazardous area classification are to be avoided, e.g. through ventilation systems, air pipes or drain systems.

2.1.7 Enclosed or semi-enclosed spaces (not containing a source of hazard) having a direct opening, including those for ventilation, into any hazardous area are to be designated as the same hazardous zone as the area in which the opening is located. See also [2.1.6] and [2.1.9]. Electrical installations are to comply with the requirements for the space or area into which the opening leads.

2.1.8 Electrical installations in spaces protected by airlocks are to be of a certified safe type unless arranged to be de-energised upon loss of overpressure in the space.

2.1.9 Except for operational reasons, access doors or other openings are not to be provided between a non-hazardous space and a hazardous area or between a zone 2 space and a zone 1 space. Where such access doors or other openings are provided, any non-hazardous enclosed space having a direct access to any zone 1 location or zone 2 location becomes the same zone as the location except that:

- a) an enclosed space with direct access to any zone 1 location can be considered as zone 2 if:
 - the access is fitted with a gastight door opening into the zone 2 space, and
 - ventilation is such that the air flow with the door open is from the zone 2 space into the zone 1 location, and
 - loss of ventilation is alarmed at a manned station;
- b) an enclosed space with direct access to any zone 2 location is not considered hazardous if:
 - the access is fitted with a self-closing gastight door that opens into the non-hazardous location, and
 - ventilation is such that the air flow with the door open is from the non-hazardous space into the zone 2 location, and
 - loss of ventilation is alarmed at a manned station;
- c) an enclosed space with direct access to any zone 1 location is not considered hazardous if:
 - the access is fitted with self-closing gastight doors forming an airlock, and
 - the space has ventilation overpressure in relation to the hazardous space, and
 - loss of ventilation overpressure is alarmed at a manned station.

Where ventilation arrangements for the intended safe space are considered sufficient by the Society to prevent any ingress of gas from the zone 1 location, the two self-closing doors forming an airlock may be replaced by a single self-closing gastight door which opens into the non-hazardous location and has no hold-back device.

2.1.10 Piping systems are to be designed to preclude direct communication between hazardous areas of different classifications and between hazardous and non-hazardous areas.

2.2 Ventilation

2.2.1 For requirements of ventilation systems in hazardous areas, see Pt C, Ch 4, Sec 2, [3.5] and Sec 7, [4].

2.3 Protection in overpressure

2.3.1 For requirements relevant to protection in overpressure, see Pt C, Ch 4, Sec 2, [3.6].

2.4 Hazardous area and electrical equipment

2.4.1 Electrical installations are to be such as to minimize the risk of fire and explosion from flammable products.

2.4.2 Electrical equipment and cables installed in hazardous areas are to be limited to those necessary for operational purposes.

2.4.3 Where electrical equipment is installed in gas-dangerous spaces or zones and is essential for operational purposes, it should be of a safe type for operation in the flammable atmosphere concerned.

2.4.4 Portable electrical equipment, supplied by cables is not permitted in hazardous areas, unless special precautions are taken (see IEC 61892-7 clause 6.5).

2.4.5 For FPSO units storing flammable liquids having a flash point not exceeding 60°C see Tab 1 and, for process plant hazardous area classification and permitted electrical equipment, see [2.5].

2.4.6 For FPSO units storing flammable liquids having a flash point exceeding 60°C see Tab 2 and, for process plant hazardous area classification and permitted electrical equipment, see [2.5].

2.4.7 For FPSO units storing cargoes heated to a temperature above their flash point and cargoes heated to a temperature within 15°C of their flash point, the requirements under [2.4.5] apply.

2.4.8 The explosion group and temperature class of electrical equipment of a certified safe type are to be at least IIA and T3 in the case of units arranged for the carriage of crude oil or other petroleum products.

2.4.9 Other characteristics may be required for dangerous products other than those above. In this case permitted certified safe type electrical equipment is to be chosen taking into account the more demanding of the required explosion groups and temperature classes of the cargoes allowed to be stored.

2.4.10 For electrical cables see Pt C, Ch 2, Sec 2, [12.2].

2.4.11 The cross-section of cables installed in hazardous areas is to be correlated to the characteristics time/current of the relevant electrical protective device in order to limit the surface temperature of the cable to a safety value obliged by the temperature class of the dangerous gas likely to be present in the area, under the most severe expected fault condition.

2.5 Process plant location classification and permitted electrical equipment

2.5.1 Hazardous location classification is to be carried out in accordance with the following requirements and IEC 60079-10, or, alternatively, with an acceptable Code or Standard giving equivalent safety. Reference may be made, for example, to IEC 60092 series, IEC 61892 series, API RP 505.

2.5.2 It is to be taken into consideration that the horizontal extent of the hazardous areas at ground level will increase with increasing relative density of the gas or vapour which may be released and the vertical extent above the source will increase with decreasing the gas or vapour relative density.

2.5.3 Zone 0 hazardous location normally include areas or spaces:

- a) within process apparatus developing flammable gas or vapours;
- b) within enclosed pressure vessels or storage tanks;
- c) around vent pipes which discharges continually or for long periods;
- d) over/near surface of flammable liquids in general.

2.5.4 Zone 1 hazardous location normally include areas or spaces:

- a) above roofs and outside sides of storage tanks;
- b) with a certain radius around the outlet of vent pipes, pipelines and safety valves;
- c) around ventilation openings from a zone 1 area;
- d) around flexible pipelines and hoses;
- e) around sample taking points (valves, etc.);
- f) around seals of pumps, compressors, and similar apparatus, if primary source of release and rooms without ventilation, with direct access from a zone 2 area; and rooms or parts of rooms containing secondary sources of release, where internal outlets indicate zone 2, but where efficient dilution of an explosive atmosphere cannot be expected because of lack of ventilation.

2.5.5 Zone 2 hazardous location normally include areas or spaces:

- a) around flanges, connections, valves, etc.;
- b) outside of zone 1, around the outlet of vent pipes, pipelines and safety valves;
- c) around vent openings from the zone 2 area;
- d) between the main deck and the production/facilities deck, unless installations on the deck result in a zone 1 area classification.

2.5.6 The following provisions are to be taken into account.

- a) Pipelines without flanges, connections, valves or other similar fittings need not be regarded as a source of release.
- b) Certain areas and spaces (rooms) are, if so indicated by the circumstances, to be classified as a more hazardous zone than set out in these examples.
- c) Certain areas and spaces (rooms) may, under certain circumstances and/or when special precautions are taken, be classified as a less hazardous zone than indicated by these examples. Such special circumstances may be, for example, shielding or reinforced ventilation arrangements.
- d) Enclosed rooms, without ventilation, with openings to an area with explosion risks, are to be classified as the same, or as a more hazardous zone than such an area.

2.5.7 Electrical installations are to be such as to minimize the risk of fire and explosion from flammable products.

2.5.8 Electrical equipment and cables installed in hazardous areas are to be limited to those necessary for operational purposes.

2.5.9 Where electrical equipment is installed in gas-dangerous spaces or zones and is essential for operational purposes, it should be of a safe type for operation in the flammable atmosphere concerned.

2.5.10 Portable electrical equipment, supplied by cables is not permitted in hazardous areas, unless special precautions are taken (see IEC 61892-7 clause 6.5).

2.5.11 Permitted electrical equipment, in hazardous location defined according to [2.5], is that indicated in Pt C, Ch 2, Sec 2, [12.1.4] to [12.1.6] as applicable.

2.5.12 The explosion group and temperature class of electrical equipment of a certified safe type are to be at least IIA and T3 in the case of units arranged for the carriage of crude oil or other petroleum products.

2.5.13 Other characteristics may be required for dangerous products other than those above. In this case permitted certified safe type electrical equipment is to be chosen taking into account the more demanding of the required explosion groups and temperature classes of the hazardous product whose gas or vapour may be present at the location.

2.5.14 For electrical cables see Pt C, Ch 2, Sec 2, [12.2].

2.5.15 The cross-section of cables installed in hazardous areas is to be correlated to the characteristics time/current of the relevant electrical protective device in order to limit the surface temperature of the cable to a safety value obliged by the temperature class of the dangerous gas likely to be present in the area, under the most severe expected fault condition.

3 Sources of electrical power and distribution systems

3.1 Power sources location

3.1.1 Sources of electrical power and their section boards and distribution boards, etc., are normally not to be located in hazardous locations.

The generating plant, switchboards and batteries are to be separated from any zone 0 by cofferdams or equivalent spaces and from other hazardous areas by gas-tight steel divisions.

Access between such spaces have to comply with [2.1.9].

Table 1 : Hazardous location classification and permitted electrical equipment - FPSO units storing flammable liquids having a flashpoint not exceeding 60°C

Hazardous area	Spaces		Electrical equipment
	N°	Description	
Zone 0	1	Interior of cargo tanks, slop tanks, any pipework of pressure relief or other venting systems for cargo and slop tanks, pipes and equipment containing cargo or developing flammable gases or vapours.	<ul style="list-style-type: none"> a) certified intrinsically safe apparatus Ex(ia); b) simple electrical apparatus and components (e.g. thermocouples, photocells, strain gauges, switching devices), included in intrinsically safe circuits of category "ia" not capable of storing or generating electrical power or energy in excess of limits stated in the relevant standards c) equipment specifically designed and certified by the appropriate authority for use in Zone 0.
Zone 1	2	Void spaces adjacent to, above or below integral cargo tanks.	<ul style="list-style-type: none"> a) any type considered for Zone 0; b) certified intrinsically safe apparatus Ex(ib); c) simple electrical apparatus and components (e.g. thermocouples, photocells, strain gauges, switching devices), included in intrinsically safe circuits of category "ib" not capable of storing or generating electrical power or energy in excess of limits stated in the relevant standards; d) hull fittings containing the terminals or shell plating penetrations for anodes or electrodes of an impressed current cathodic protection system, or transducers such as those for depth sounding or log systems, provided that such fittings are of gas-tight construction or housed within a gas-tight enclosure and are not located adjacent to a cargo tank bulkhead. The design of such fittings or their enclosures and the means by which cables enter, as well as any testing to establish their gas-tightness, are to be to the satisfaction of the Society. The associated cables are to be protected as indicated in item e); e) electrical cables passing through the spaces. Such cables are to be installed in heavy gauge steel pipes with gas-tight joints. Expansion bends are not to be fitted in these spaces.

Hazardous area	Spaces		Electrical equipment
	N°	Description	
Zone 1	3	Hold spaces containing independent cargo tanks.	<ul style="list-style-type: none"> a) any type considered for Zone 0; b) certified intrinsically safe apparatus Ex(ib); c) simple electrical apparatus and components (e.g. thermocouples, photocells, strain gauges, switching devices), included in intrinsically safe circuits of category "ib" not capable of storing or generating electrical power or energy in excess of limits stated in the relevant standards; d) Zone 1 certified safe type lighting fittings divided between at least two independent final sub-circuits. All switches and protective devices are to interrupt all poles or phases and are to be located in a non-hazardous area; e) hull fittings containing the terminals or shell plating penetrations for anodes or electrodes of an impressed current cathodic protection system, or transducers such as those for depth sounding or log systems, provided that such fittings are of gas-tight construction or housed within a gas-tight enclosure and are not located adjacent to a cargo tank bulkhead. The design of such fittings or their enclosures and the means by which cables enter, as well as any testing to establish their gas-tightness, are to be to the satisfaction of the Society; f) electrical cables passing through the spaces.
Zone 1	4	Cofferdams and permanent (for example, segregated) ballast tanks adjacent to cargo tanks.	<ul style="list-style-type: none"> a) any type considered for Zone 0; b) certified intrinsically safe apparatus Ex(ib); c) simple electrical apparatus and components (e.g. thermocouples, photocells, strain gauges, switching devices), included in intrinsically safe circuits of category "ib" not capable of storing or generating electrical power or energy in excess of limits stated in the relevant standards; d) hull fittings containing the terminals or shell plating penetrations for anodes or electrodes of an impressed current cathodic protection system, or transducers such as those for depth sounding or log systems, provided that such fittings are of gas-tight construction or housed within a gas-tight enclosure and are not located adjacent to a cargo tank bulkhead. The design of such fittings or their enclosures and the means by which cables enter, as well as any testing to establish their gas-tightness, are to be to the satisfaction of the Society. The associated cables are to be protected as indicated in item e); e) electrical cables passing through the spaces. Such cables are to be installed in heavy gauge steel pipes with gas-tight joints. Expansion bends are not to be fitted in these spaces. Corrosion-resistant pipes, providing adequate mechanical protection, are to be used in compartments which may be filled with sea water (e.g. permanent ballast tanks).

Hazardous area	Spaces		Electrical equipment
	N°	Description	
Zone 1	5	Cargo pump rooms.	<p>a) any type considered for Zone 0;</p> <p>b) certified intrinsically safe apparatus Ex(ib);</p> <p>c) simple electrical apparatus and components (e.g. thermocouples, photocells, strain gauges, switching devices), included in intrinsically safe circuits of category "ib" not capable of storing or generating electrical power or energy in excess of limits stated in the relevant standards;</p> <p>d) hull fittings containing the terminals or shell plating penetrations for anodes or electrodes of an impressed current cathodic protection system, or transducers such as those for depth sounding or log systems, provided that such fittings are of gas-tight construction or housed within a gas-tight enclosure and are not located adjacent to a cargo tank bulkhead. The design of such fittings or their enclosures and the means by which cables enter, as well as any testing to establish their gas-tightness, are to be to the satisfaction of the Society. The associated cables are to be protected as indicated in item g);</p> <p>e) Zone 1 certified safe lighting fittings divided between at least two independent final sub-circuits. All switches and protective devices are to interrupt all poles or phases and are to be located in a non-hazardous area. The lighting fittings, switches and protective devices are to be suitably labelled for identification purposes. See also Ch 1, Sec 6, [4.2.3];</p> <p>f) Zone 1 certified safe type visual and/or acoustic indicators (e.g. for general alarm, fire-extinguishing media alarm, etc.);</p> <p>g) Zone 1 certified safe type sensors for gas detection systems;</p> <p>h) cables, other than those supplying lighting fittings and those of intrinsically safe circuits, where it is necessary for them to pass through cargo pump rooms. Such cables are to be installed in heavy gauge steel pipes with gas-tight joints.</p>
Zone 1	6	Enclosed or semi-enclosed spaces immediately above cargo tanks (e.g. 'tweendecks) or having bulkheads above and in line with cargo tank bulkheads, unless protected by a diagonal plate acceptable to the Society.	<p>a) any type considered for Zone 0;</p> <p>b) certified intrinsically safe apparatus Ex(ib);</p> <p>c) simple electrical apparatus and components (e.g. thermocouples, photocells, strain gauges, switching devices), included in intrinsically safe circuits of category "ib" not capable of storing or generating electrical power or energy in excess of limits stated in the relevant IEC or EN Standards;</p> <p>d) Zone 1 certified safe type lighting fittings divided between at least two independent final sub-circuits. All switches and protective devices are to interrupt all poles or phases and are to be located in a non-hazardous area. The lighting fittings, switches and protective devices are to be suitably labelled for identification purposes;</p> <p>e) electrical cables passing through the spaces;</p> <p>f) in 'tweendeck spaces immediately above cargo tanks, any electrical equipment other than that in (a), (b), (c) and (d), provided that it is housed in a compartment: <ul style="list-style-type: none"> • which is suitably mechanically ventilated, • having access solely from the deck above, • whose floor is separated from the cargo tanks by a cofferdam, • whose boundaries are oil-tight and gas-tight with respect to the cofferdam and the 'tweendeck spaces. </p>

Hazardous area	Spaces		Electrical equipment
	N°	Description	
Zone 1	7	Spaces other than cofferdams, adjacent to and below the top of a cargo tank (e.g. trunks, passageways and holds) as well as double bottoms and pipe tunnels below cargo tanks.	<ul style="list-style-type: none"> a) any type considered for Zone 0; b) certified intrinsically safe apparatus Ex(ib); c) simple electrical apparatus and components (e.g. thermocouples, photocells, strain gauges, switching devices), included in intrinsically safe circuits of category "ib" not capable of storing or generating electrical power or energy in excess of limits stated in the relevant standards; d) hull fittings containing the terminals or shell plating penetrations for anodes or electrodes of an impressed current cathodic protection system, or transducers such as those for depth sounding or log systems, provided that such fittings are of gas-tight construction or housed within a gas-tight enclosure and are not located adjacent to a cargo tank bulkhead. The design of such fittings or their enclosures and the means by which cables enter, as well as any testing to establish their gas-tightness, are to be to the satisfaction of the Society. The associated cables are to be protected as indicated in item f); e) Zone 1 certified safe type lighting fittings divided between at least two independent final sub-circuits. All switches and protective devices are to interrupt all poles or phases and are to be located in a non-hazardous area. The lighting fittings, switches and protective devices are to be suitably labelled for identification purposes; f) electrical cables passing through the spaces; through-runs of cables, with the exception of those for intrinsically safe apparatus, will be specially considered by the Society.
Zone 1	8	Areas on open deck, or semi-enclosed spaces on open deck, within 3m of any cargo tank outlet (tank hatches, sight ports, tank cleaning openings, ullage openings, sounding pipes etc.), cargo manifold valves, cargo valves, cargo pipe flanges, cargo pump room and other enclosed hazardous space entrance(s) and ventilation outlets, and cargo tank ventilation outlets and cargo tank openings for pressure release provided to permit the flow of small volumes of gas or vapour mixtures caused by thermal variation.	<ul style="list-style-type: none"> a) any type considered for Zone 0; b) certified intrinsically safe apparatus Ex(ib); c) simple electrical apparatus and components (e.g. thermocouples, photocells, strain gauges, switching devices), included in intrinsically safe circuits of category "ib" not capable of storing or generating electrical power or energy in excess of limits stated in the relevant standards; d) certified flameproof Ex(d); e) certified pressurised Ex(p); f) certified increased safety Ex(e); g) certified encapsulated Ex(m); h) certified sand filled Ex(q); i) electrical cables passing through the spaces. Expansion bends are not to be fitted in these spaces.
Zone 1	9	Areas on open deck, or semi-enclosed spaces on open deck, above and in the vicinity of any cargo gas outlet intended for the passage of large volumes of gas or vapour mixture during cargo loading and ballasting or during discharging, within a vertical cylinder of unlimited height and 6m radius centred upon the centre of the outlet, and within a hemisphere of 6m radius below the outlet.	As allowed for spaces under item 8.
Zone 1	10	Areas on open deck, or semi-enclosed spaces on open deck, within 1,5m of cargo pump room entrances, cargo pump room ventilation inlets, openings into cofferdams or other Zone 1 spaces.	As allowed for spaces under item 8.

Hazardous area	Spaces		Electrical equipment
	N°	Description	
Zone 1	11	Areas on open deck within spillage coamings surrounding cargo manifold valves and 3 m beyond these, up to a height of 2,4 m above the deck.	As allowed for spaces under item 8.
Zone 1	12	Areas on open deck over all cargo tanks (including all ballast tanks within the cargo tank area) where structures are restricting the natural ventilation and to the full breadth of the unit plus 3m fore and aft of the forward-most and aft-most cargo tank bulkhead, up to a height of 2,4m above the deck.	As allowed for spaces under item 8 except that expansion bends are allowed in these areas.
Zone 1	13	Compartments for cargo hoses.	As allowed for spaces under item 7 a) b) c) e) and electrical cables passing through the spaces.
Zone 1	14	Enclosed or semi-enclosed spaces in which pipes containing cargoes are located.	As allowed for spaces under item 13.
Zone 2	15	Areas of 1,5 m surrounding the Zone 1 spaces defined in item 8.	<ul style="list-style-type: none"> a) any type considered for Zone 1; b) electrical equipment of a type which ensures the absence of sparks, arcs and "hot spots" during its normal operation; c) electrical equipment tested specially for Zone 2 (e.g. type "n" protection); d) electrical equipment encapsulated and acceptable to the Society.
Zone 2	16	Areas 4m beyond the cylinder and 4m beyond the sphere defined in item 9.	As allowed for spaces under item 15.
Zone 2	17	Areas on open deck extending to the coamings fitted to keep any spills on deck and away from the accommodation and service areas and 3m beyond these up to a height of 2,4m above the deck.	As allowed for spaces under item 15.
Zone 2	18	Areas on open deck over all cargo tanks (including all ballast tanks within the cargo tank area) where unrestricted natural ventilation is guaranteed and to the full breadth of the unit plus 3m fore and aft of the forward-most and aft-most cargo tank bulkhead, up to a height of 2,4m above the deck surrounding open or semi-enclosed spaces of Zone 1.	As allowed for spaces under item 15.
Zone 2	19	<p>Spaces forward of the open deck areas to which reference is made in item 13 and item 19, below the level of the main deck, and having an opening on the main deck or at a level less than 0,5m above the main deck, unless:</p> <ul style="list-style-type: none"> a) the entrances to such spaces do not face the cargo tank area and, together with all other openings to the spaces, including ventilation system inlets and exhausts, are situated at least 5m from the foremost cargo tank and at least 10m measured horizontally from any cargo tank outlet or gas or vapour outlet; and b) the spaces are mechanically ventilated. 	As allowed for spaces under item 15.

Table 2 : Hazardous location classification and permitted electrical equipment - FPSO units storing flammable liquids having a flashpoint exceeding 60°C unheated or heated to a temperature below and not within 15°C of their flashpoint

Hazardous area	Spaces		Electrical equipment
	N°	Description	
Zone 2	1	Interior of cargo tanks, slop tanks, any pipework of pressure relief or other venting systems for cargo and slop tanks, pipes and equipment containing cargo	<ul style="list-style-type: none"> a) any type considered for Zone 1; b) electrical equipment of a type which ensures the absence of sparks, arcs and "hot spots" during its normal operation; c) electrical equipment tested specially for Zone 2 (e.g. type "n" protection);

SECTION 6

SAFETY SYSTEMS

1 General

1.1 Purpose and application

1.1.1 The requirements of this Section apply to FPSO units in addition to those contained in Part C, Chapter 4, Section 1 of these Rules.

1.2 Documents to be submitted

1.2.1 In addition to the documentation required in Section 7 the following are to be sent for approval:

- a) diagram of emergency shutdown circuits;
- b) cause and effects diagrams.

2 Fire and gas detection

2.1 General requirements

2.1.1 Reference is to be made to the provisions laid down Section 7, item [6].

3 Emergency shut down systems

3.1 General requirements and definitions

3.1.1 The safest conditions for the systems on board are to be defined.

3.1.2 All equipment and systems are to be equipped with indicating or monitoring instruments and devices necessary for safe operation.

3.1.3 Emergency shutdown systems are to be provided against hazardous events.

Production systems are to be equipped with shutdown systems.

Systems that could endanger the safety if they fail or operate outside pre-set conditions are to be provided with automatic shutdown.

3.1.4 An emergency shutdown system (ESD) includes:

- a) manual input devices (push buttons)
- b) interfaces towards other safety systems, e.g.:
 - fire detection system
 - gas detection system
 - alarm and communication systems
 - process shutdown system
 - fire-fighting systems
 - ventilation systems
- c) a central control unit receiving and evaluating signals from the manual input devices and the interfaced systems,

and creating output signals to devices that are to be shut down or activated. The ESD central control unit is to include a device providing visual indication of initiated inputs and activated outputs and a local audible alarm

- d) output actuators, e.g. relays, valves and dampers, including status indicators
- e) signal transfer lines between the ESD central control unit and all input devices, interfaced systems and output actuators
- f) power supply.

3.1.5 In the context of these requirements under [3], 'circuit' is defined as any signal transfer facility, e.g. electrical, pneumatic, hydraulic, optical or acoustic.

3.1.6 A normally energised circuit is a circuit where energy is present, e.g. an electrical current or pneumatic or hydraulic pressure, when the circuit is not activated by the shutdown system.

3.1.7 A normally de-energised circuit is a circuit where energy is not present when the circuit is not activated by the shutdown system.

3.2 Basic design principles

3.2.1 All shutdowns are to be executed in a predetermined logical manner. The shutdown system is normally to be designed in a hierarchical manner where higher level shutdowns automatically initiate lower level shutdowns.

3.2.2 Definition of the shutdown logic and required response times are to be based on consideration of dynamic effects and interactions between systems.

3.2.3 Shutdown is not to result in adverse cascade effects, which depends on activation of other protection devices to maintain a plant in a safe condition.

3.2.4 The shutdown system is to be designed to ensure that any ongoing operations can be terminated safely when a shutdown is activated.

3.2.5 Inter-trips between process systems are to be initiated as a result of any initial event which could cause undesirable cascade effects in other parts of the plant before operator intervention can be realistically expected.

3.2.6 Emergency shutdown is to initiate a process shutdown.

3.2.7 The shutdown system is to be completely independent of control systems used for normal operation. See also Pt C, Ch 3, Sec 2, [1.1.4] of the Rules for the Classification of Ships.

3.2.8 The shutdown system is to be capable to monitor critical parameters and bring the system to a safe condition if specified conditions are exceeded. See also Pt C, Ch 3, Sec 2, [7] of the Rules for the Classification of Ships.

3.2.9 The system is to be designed so that the risk of unintentional shutdown caused by malfunction or inadvertent operation is minimised.

3.2.10 The system is to be designed to allow testing without interrupting other systems on board.

3.2.11 The central control unit is to be located in a non-hazardous and continuously manned area.

3.2.12 The system is to be powered from a monitored Uninterruptible Power Supply (UPS) capable of at least 30 minutes continuous operation on loss of its electrical power supply systems. The UPS is to be powered from both the main and the emergency power system.

3.3 Design and functional requirements

3.3.1 Upon failure of the shutdown system, all connected systems are to default to the safest condition [3.1.1] for the unit or installation.

3.3.2 Failures to be considered for the shutdown system are to include broken connections and short-circuits on input and output circuits, loss of power supply and, if relevant, loss of communication with other systems.

3.3.3 For a shutdown system with only normally energized outputs, all inputs are to be normally energized.

3.3.4 For a shutdown system with one or more normally de-energized outputs, all inputs able to activate a normally de-energized output are to be normally de-energized. All normally de-energized input and output circuits are to be monitored for broken connection and short-circuit.

3.3.5 Shutdown is not to require unrealistically quick or complex intervention by the operator.

3.3.6 Shutdowns on a hierarchical level are automatically to include shutdowns on lower levels.

3.3.7 Shutdown is to initiate alarm at the control station. The initiating device and operating status of devices affected by the shutdown action are to be indicated at the control station (e.g. valve position, unit tripped, etc.).

3.3.8 Personnel lifts, work platforms and other man-riding equipment are to be designed to enable safe escape after an emergency shutdown, e.g. by controlled descent to an access point on a lower level.

3.3.9 Systems which are not permanently attended during operation, and which could endanger safety if they fail, are to be provided with automatic safety control, alert and alarm systems.

3.3.10 Plants that are protected by automatic safety systems are to have pre-alarms to alert when operating parameters are exceeding normal levels.

3.3.11 -

The shutdown commands are not to be automatically reset. In case local resets on shut down devices are provided, the indication of the shut down device status is to be given at the main control room.

3.4 Automatic and manual shutdown

3.4.1 Shutdowns are normally to be automatically initiated, however solely manually initiated actions may be provided where automatic action could be detrimental to safety.

3.4.2 Systems designed for automatic shutdown are also to be designed to enable manual shutdown.

3.4.3 Alarms for manual initiation are to be clear and are to be readily identifiable at a permanently manned control station.

3.4.4 In all shutdown systems, it is to be possible to manually activate all levels of shutdown at the control station.

3.4.5 Other manual shutdown buttons are to be located at strategic locations on the unit or installation.

3.5 Electrical equipment for use in an emergency

3.5.1 The following systems are to be operable after abandon unit shutdown:

- a) emergency lighting, for half an hour at:
 - every embarkation station on deck and over sides
 - in all service and accommodation alleyways, stairways and exits, personnel lift cars, and personnel lift trunks
 - in machinery spaces and main generating stations including their control positions
 - in all control stations and machinery control rooms
- b) general alarm
- c) public address
- d) battery supplied radio-communication.

3.5.2 Electrical equipment left operational after abandon unit shutdown is to be suitable for operation in zone 2 areas with the exceptions given in [3.3.7].

3.5.3 Electrical equipment located in non-hazardous areas affected by a gas release, which is left operational after gas detection is to be suitable for zone 2, with the exceptions given in [3.3.7].

3.5.4 Safety critical, uncertified electrical equipment may be left operational after ESD or gas detection affecting its area of location, provided that:

- the ventilation to the room where the equipment is located is isolated
- gas detectors are installed in the room where the equipment is located
- facilities for manual shutdown of the equipment are available.

SECTION 7

FIRE PROTECTION, DETECTION AND EXTINCTION

1 General

1.1 Application

1.1.1 This Section provides, for units having the service notation **FPSO**, specific requirements for:

- Structural fire protection;
- Ventilation systems in hazardous spaces
- Active fire protection.

1.1.2 The requirements of this Section, with the exception of items [4] and [6] are not applicable for the purpose of classification, except where the Society carries out surveys relevant to fire protection statutory requirements on behalf

of the flag Administration. In such cases, fire protection statutory requirements are considered a matter of class and therefore compliance with these requirements is also verified by the Society for classification purposes.

1.1.3 Requirements contained in this Chapter are additional to those contained in Part C, Chapter 4, Section 2 except for item [2.2] that is to be apply in lieu of Part C, Chapter 4, Section 2, [3.2.1] a) and [3.2.6] a).

1.2 Documentation to be submitted

1.2.1 In addition to those listed under Pt C, Ch 4, Sec 2, Tab 1 the documents listed in Tab 1 are to be submitted for approval.

Table 1 : Documents to be submitted

No	(1)	Document (2)
1	A	Fixed deck foam systems
2	A	Fixed fire extinguishing systems in cargo pump rooms
3	A	Fixed water deluge system
4	A	Arrangement of fixed inert gas systems
<p>(1) A : to be submitted for approval, in four copies</p> <p>(2) Plans are to be schematic and functional and to contain all information necessary for their correct interpretation and verification, such as:</p> <ul style="list-style-type: none"> • service pressures • capacity and head of pumps and compressors, if any • materials and dimensions of piping and associated fittings • volumes of protected spaces, for gas and foam fire-extinguishing systems • surface areas of protected zones for automatic sprinkler and pressure water-spraying, low expansion foam and powder fire-extinguishing systems • capacity, in volume and/or in mass, of vessels or bottles containing the extinguishing media or propelling gases, for gas, automatic sprinkler, foam and powder fire-extinguishing systems • type, number and location of nozzles of extinguishing media for gas, automatic sprinkler, pressure water-spraying, foam and powder fire-extinguishing systems. <p>All or part of the information may be provided, instead of on the above plans, in suitable operating manuals or in specifications of the systems.</p>		

2 Cargo area

2.1 Separation of cargo oil tanks

2.1.1 SOLAS Regulation II-2/4.5.1 applies taking into account the unit's lay-out.

2.2 Restrictions on boundary openings

2.2.1 SOLAS Regulation II-2/4.5.2 applies taking into account the unit's lay-out.

2.3

2.3.1 Drip pans for collecting residues in cargo lines and hoses are to be provided in the area of pipe and hose connections under the manifold area. Cargo hoses and tank washing hoses are to have electrical continuity over their entire lengths including couplings and flanges (except shore connections) and are to be earthed for removal of electrostatic charges.

3 Structural fire protection

3.1

3.1.1 Exterior boundaries of superstructures and deckhouses enclosing accommodation spaces, services spaces, control stations and machinery spaces including any overhanging decks which support such spaces, are to be constructed to "A-60" standard for the whole of the portion which faces the tank area, and on the outward sides for a distance of 3 m from the end boundary facing the tank cargo area. In the case of the sides of those superstructures and deckhouses, such insulation is to be carried up to the underside of the deck of the navigation bridge, where fitted.

3.1.2 Boundaries separating cargo pump rooms and machinery spaces of category A are to meet at least the A-0 class standard.

4 Ventilation systems in hazardous spaces

4.1 Ventilation of other enclosed or semi-enclosed spaces within tank area

4.1.1 The ventilation system of these spaces is to have sufficient capacity to minimize the possibility of accumulation of flammable vapours. The number of changes of air is to be at least 20 per hour, based upon the gross volume of the space. The air ducts are to be arranged so that all of the space is effectively ventilated. Different values of air changes may be required or accepted by the Society based on the purpose of the space under consideration.

4.2 Ventilation of cargo pump rooms

4.2.1 The ventilation is to have sufficient capacity to minimize the possibility of accumulation of flammable vapours. The number of changes of air is to be at least 20 per hour, based upon the gross volume of the space. The air ducts are to be arranged so that all of the space is effectively ventilated.

4.2.2 The ventilation system capable of providing the required air changes per hour is to comply with the following:

- a) in order to avoid air stagnation zones, air exhaust ports inside the pump room are to be adequately distributed and the various landings are to consist of open gratings or perforated flats
- b) inlet ducts are generally to end at the top of the room and outlet ducts are to extend below the floor plates, with suction ports at the level of the upper edge of ordinary floors or bottom longitudinals
- c) in addition, suction ducts are to be provided with an emergency intake at approximately 2,20 m above the pump room lower grating, with a shutter capable of being opened or closed both at lower grating level and from the weather deck level, so that suction normally occurs through the lower suction ports and, in the event of the pump room flooding, through those at the top branched from the emergency intake
- d) an arrangement involving a specific ratio of areas of upper emergency and lower main ventilator openings, which can be shown to result in at least the required 20 air changes per hour through the lower inlets, can be adopted without the use of shutters. When the lower access inlets are closed then at least 15 air changes per hour are to be obtained through the upper inlets.

4.2.3 Lighting in cargo pump rooms, except emergency lighting, is to be interlocked with ventilation such that the ventilation is in operation when the lighting is switched on. Failure of the ventilation system is not to cause the lighting to go out.

5 Active fire protection

5.1 Fixed fire extinguishing systems water demand

5.1.1 When deck foam in item [5.2] and/or water deluge systems in item [5.5.1] are supplied by fire pumps, their capacity is to be in compliance with Chapter 4, Section 2, [5.1.1] and adequate to the worst fire scenario likely to be encountered. The scenario is to be evaluated upon case-by-case considerations, taking into account the actual lay-out of the production and storage area of the unit.

5.1.2 Based on item [5.1.1], the Society may request a calculation report, showing the criteria adopted for the design of the pumps.

5.2 Fixed deck foam system

5.2.1 General requirements

- a) The cargo tank deck area is to be protected by a fixed deck foam system capable of delivering foam to the entire cargo tank deck area (including loading and discharge manifold area) as well as into any cargo tank the deck of which has been ruptured.

Where the unit is provided with production equipment located on modules above the cargo deck area, the efficiency of the foam delivery is not to be impaired in way of structure supports of production modules. Alternative arrangements, such as fixed foam/water spray systems, may be adopted.

- b) The deck foam system is to be capable of simple and rapid operation.
- c) Operation of a deck foam system at its required output is to permit the simultaneous use of the minimum required number of jets of water at the required pressure from the fire main.
- d) A common line for fire main and deck foam line can only be accepted if it can be demonstrated that the hose nozzles can be effectively controlled by one person when supplied from the common line at a pressure needed for operation of the monitors. Additional foam concentrate is to be provided for operation of 2 nozzles for the same period of time required for the foam system. The simultaneous use of the minimum required jets of water is to be possible on deck over the full length of the unit, in the accommodation spaces, service spaces, control stations and machinery spaces.

5.2.2 Component requirements

- a) Foam solution and foam concentrate

The rate of supply of foam solution is to be not less than the greatest of the following:

- 0,6 l/min per square metre of cargo tanks deck area, where cargo tank deck area means the maximum breadth of the unit multiplied by the total longitudinal extent of the cargo tank spaces
- 6 l/min per square metre of the horizontal sectional area of the single tank having the largest such area, or
- 3 l/min per square metre of the area protected by the largest monitor, such area being entirely forward of the monitor, but not less than 1250 l/min.

- b) Sufficient foam concentrate is to be supplied to ensure at least 20 min of foam generation in units fitted with an inert gas installation or 30 min of foam generation in units not fitted with an inert gas installation when using solution rates stipulated in item 1 above, whichever is the greatest. The foam expansion ratio (i.e. the ratio of the volume of foam produced to the volume of the mixture of water and foam-making concentrate supplied) is not generally to exceed 12 to 1. Where systems essentially produce low expansion foam but at an expansion ratio slightly in excess of 12 to 1 the quantity of foam solution available is to be calculated as for 12 to 1 expansion ratio systems (see Note 1). When medium expansion ratio foam (see Note 2) (between 50 to 1 and

150 to 1 expansion ratio) is employed, the application rate of the foam and the capacity of a monitor installation are to be to the satisfaction of the Society.

Note 1: Refer to the Guidelines for the performance and testing criteria and surveys of low-expansion foam concentrates for fixed fire-extinguishing systems (MSC/Circ.1312).

Note 2: Refer to the Guidelines for the performance, testing criteria and surveys of medium expansion foam concentrates for fixed fire-extinguishing systems (MSC/Circ.798).

5.2.3 Monitors and foam applicators

- a) Foam from the fixed foam system is to be supplied by means of monitors and foam applicators. At least 50 per cent of the foam solution supply rate required in the first two items of [5.2.2] a) is to be delivered from each monitor. On units of less than 4000 tonnes deadweight, the Society may not require installation of monitors but only applicators. However, in such case the capacity of each applicator is to be at least 25 per cent of the foam solution supply rate required in the first two items of [5.2.2] a).
- b) The capacity of any monitor is to be at least 3 l/minute of foam solution per square metre of deck area protected by that monitor, such area being entirely forward of the monitor. Such capacity is to be not less than 1250 l/minute.
- c) The capacity of any applicator is to be not less than 400 l/min and the applicator throw in still air conditions is to be not less than 15 m.

5.2.4 Installation requirements

- a) Main control station

The main control station for the system is to be suitably located outside the cargo area, adjacent to the accommodation spaces and readily accessible and operable in the event of fire in the areas protected.

- b) Monitors

The number and position of monitors are to be such as to comply with previous item [5.2.1] a).

The distance from the monitor to the farthest extremity of the protected area forward of that monitor is to be not more than 75 per cent of the monitor throw in still air conditions.

A monitor and hose connection for a foam applicator are to be situated both port and starboard at the front of the poop or accommodation spaces facing the cargo tank deck. On units of less than 4000 tonnes deadweight a hose connection for a foam applicator is to be situated both port and starboard at the front of the poop or accommodation spaces facing the cargo tank deck.

5.2.5 Applicators

- a) The number of foam applicators provided is to be not less than four. The number and disposition of foam main outlets are to be such that foam from at least two applicators can be directed on to any part of the cargo tank deck area.
- b) Applicators are to be provided to ensure flexibility of action during fire-fighting operations and to cover areas screened from the monitors.

5.2.6 Isolation valves

Valves are to be provided in the foam main, and in the fire main when this is an integral part of the deck foam system, immediately forward of any monitor position to isolate damaged sections of those mains.

5.3 Protection of cargo pump rooms

5.3.1 Each cargo pump room is to be provided with one of the following fixed fire-extinguishing systems operated from a readily accessible position outside the pump room. Cargo pump rooms are to be provided with a system suitable for machinery spaces of category A.

- a) A carbon dioxide system complying with the provisions Chapter 5 of the Fire Safety Systems Code and with the following:
 - the alarms giving audible warning of the release of fire-extinguishing medium are to be safe for use in a flammable cargo vapour/air mixture; and
 - a notice is to be exhibited at the controls stating that, due to the electrostatic ignition hazard, the system is to be used only for fire extinguishing and not for inerting purposes.
- b) A high-expansion foam system complying with the provisions Chapter 6 of the Fire Safety Systems Code, provided that the foam concentrate supply is suitable for extinguishing fires involving the cargoes carried.
- c) A fixed pressure water-spraying system complying with the provisions of Chapter 7 of the Fire Safety Systems Code.

5.3.2 Where the extinguishing medium used in the cargo pump room system is also used in systems serving other spaces, the quantity of medium provided or its delivery rate need not be more than the maximum required for the largest compartment.

5.4 Protection of other enclosed spaces within the cargo tank deck area

5.4.1 The requirements set out in [5.3] are applicable, at the discretion of the Society, to any other enclosed or semi-enclosed space within the cargo tank deck area.

5.5 Protection of production area

5.5.1 Fixed water deluge system:

- a) A fixed water deluge system for cooling, fire prevention and control is to be installed to protect:
 - Processing areas and equipment
 - Crude oil and gas manifolds on deck
 - Wellhead/Turret areas including swivel deck
 - Well test areas

Gas handling equipment, such as gas compressor skids, the water spray system is not required if the equipment is provided with an automatic blowdown upon the process shutdown.

- b) The system is to be capable of covering all areas mentioned in a) with a uniformly distributed water spray of not less than:
 - 10 l/m² per minute for processing areas;
 - 10 l/m² per minute for exposed surface of area of uninsulated vessels;
 - 6 l/m² per minute for exposed surface of area of insulated vessels;
 - 20 l/m² per minute for wellheads and turret areas.
- c) The system is to be capable of being actuated both automatically upon the activation of the fire detection system in item [5.5.2] and manually.
- d) The system may be divided into sections, taking into account the storage deck area extension and the production equipment lay-out. Each section is to be isolated by a single valve. Valves are to be located in an accessible position outside the fire zone they protect.
- e) For each section identified in item d) above, the water deluge pumps are to be capable of supplying the section supposed to be in fire and the adjacent sections, for cooling and prevention purposes. Where suitable fire resistant divisions or adequate distance are displayed between sections, considerations may be made to exclude adjacent sections when calculating the minimum water supply capability.

5.5.2 Automatic fire detection and alarm system

An automatic fire detection and alarm system is to be installed in the areas listed in [5.5.1] a).

6 Fire and gas detection

6.1 Fire detection and alarm system

6.1.1 An automatic fire detection and alarm system is to be installed in accommodation and service spaces, machinery spaces, air intakes of ventilation systems, production areas and in any space containing process equipment related to hydrocarbon or any other flammable liquids, including wellheads, turrets, tank areas.

6.2 Gas detection system

6.2.1 A fixed gas detection system is to be provided for the following areas:

- hazardous areas, except in Zone 0 and areas mechanically ventilated;
- ventilation outlets from hazardous areas mechanically ventilated;
- intakes for ventilation air, including those for accommodation spaces, service spaces and control stations.

Where the atmosphere in double hull spaces cannot be reliably measured using flexible gas sampling hoses, such spaces shall be fitted with permanent gas sampling lines. The configuration of gas sampling lines shall be adapted to the design of such spaces.

6.2.2 In cases where concentration of H₂S is expected, equipment suitable for measuring H₂S is to be installed. Visual and audible alarms are to be activated in the main control stations at 10 ppm H₂S.

6.2.3 In cargo pump room, sampling points or detector heads shall be located in suitable positions in order that potentially dangerous leakage is readily detected. Suitable positions may be the exhaust ventilation duct and lower parts of the pump room above the floor plates.

When the gas concentration reaches a pre-set level, which shall not be higher than 10% LFL, a continuous audible and visual alarm signal shall be automatically initiated in the pump-room and to continuously manned stations to alert personnel to the potential hazard.

Sequential sampling is acceptable as long as it is dedicated for the pump room only, including exhaust ducts, and the sampling time is reasonably short.

7 Personnel protection

7.1 Firefighter's outfits

7.1.1 Two fire fighter's outfits are to be provided, in addition to those required in Pt C, Ch 4, Sec 2, [5.8.2].

8 Inert gas system

8.1 Application

8.1.1 The protection of the cargo tanks is to be achieved by a fixed inert gas system designed, constructed and tested in accordance with the requirements of Chapter 15 of the Fire Safety System Code, except that, in lieu of the above, the Society, after having given consideration to the unit's arrangement and equipment, may accept other fixed installations if they afford protection equivalent to the above.

The requirements for alternative installations are given in [8.3] below.

8.1.2 Units operating with a cargo tank cleaning procedure using crude oil washing, are to be fitted with an inert gas system complying with the requirements of Chapter 15 of the Fire Safety System Code and with fixed tank washing machines.

8.1.3 Units required to be fitted with inert gas systems are to comply with the following provisions:

- double hull spaces are to be fitted with suitable connections for the supply of inert gas
- where hull spaces are connected to a permanently fitted inert gas distribution system, means are to be provided to prevent hydrocarbon gases from the cargo tanks entering the double hull space through the system and
- where such spaces are not permanently connected to an inert gas distribution system, appropriate means are to be provided to allow connection to the inert gas main.

8.2 General requirements for inert gas systems

8.2.1 The inert gas system is to be capable of inerting, purging and gas-freeing empty cargo tanks and maintaining the atmosphere in cargo tanks with the required oxygen content.

8.2.2 Units fitted with a fixed inert gas system are to be provided with a closed ullage system.

8.3 Requirements for equivalent systems

8.3.1 -

When an installation equivalent to a fixed inert gas system is installed, it is to be:

- a) capable of preventing dangerous accumulations of explosive mixtures in intact cargo tanks during normal service throughout the ballast condition and necessary in-tank operations, and
- b) so designed as to minimise the risk of ignition from the generation of static electricity by the system itself.

APPENDIX 1

DEVICES TO PREVENT THE PASSAGE OF FLAME INTO THE CARGO TANKS

1 General

1.1 Application

1.1.1 This Appendix is intended to cover the design, testing, location and maintenance of "devices to prevent the passage of flame into cargo tanks" (hereafter called "devices") of FPSO.

1.1.2 Units fitted with an inert gas system in accordance with Sec 7, [6] are to be fitted with devices which comply with this Appendix, except that the tests specified in [4.2.3] and [4.3.3] are not required. Such devices are only to be fitted at openings unless they are tested in accordance with [4.4].

Note 1: This Appendix is intended for devices protecting cargo tanks containing crude oil and petroleum products. Devices are to be tested and located in accordance with this Appendix.

1.1.3 Devices are installed to protect:

- a) openings designed to relieve pressure or vacuum caused by thermal variations (see Sec 4, [2.1.2], item a));
- b) openings designed to relieve pressure or vacuum during cargo loading, ballasting or discharging (see Sec 4, [2.1.2], item b));
- c) outlets designed for gas-freeing (see Sec 4, [3.1.1]).

1.1.4 Devices are not to be capable of being bypassed or blocked open unless they are tested in the bypassed or blocked open position in accordance with [4].

1.1.5 This Appendix does not include consideration of sources of ignition such as lightning discharges, since insufficient information is available to formulate equipment recommendations. All cargo handling, tank cleaning and ballasting operations are to be suspended on the approach of an electrical storm.

1.1.6 This Appendix is not intended to deal with the possibility of the passage of flame from one cargo tank to another on tankers with common venting systems.

1.1.7 When outlet openings of gas-freeing systems on tankers not fitted with inert gas systems are required to be protected with devices, they are to comply with this Appendix except that the tests specified in [4.2.3] and [4.3.3] are not required.

1.1.8 Certain of the tests prescribed in [4] of this Appendix are potentially hazardous, but no attempt is made in this Appendix to specify safety requirements for these tests.

1.2 Definitions

1.2.1 Premise

For the purpose of this Appendix, the definitions given in the following paragraphs are applicable.

1.2.2 Flame arrester

A flame arrester is a device to prevent the passage of flame in accordance with a specified performance standard. Its flame arresting element is based on the principle of quenching.

1.2.3 Flame screen

A flame screen is a device utilising wire mesh to prevent the passage of unconfined flames in accordance with a specified performance standard.

1.2.4 Flame speed

The flame speed is the speed at which a flame propagates along a pipe or other system.

1.2.5 Flashback

Flashback is the transmission of a flame through a device.

1.2.6 High velocity vent

A high velocity vent is a device to prevent the passage of flame consisting of a mechanical valve which adjusts the opening available for flow in accordance with the pressure at the inlet of the valve in such a way that the efflux velocity cannot be less than 30 m/s.

1.2.7 Pressure/vacuum valve

A pressure/vacuum valve is a device designed to maintain pressure and vacuum in a closed container within preset limits.

Note 1: Pressure/vacuum valves are devices to prevent the passage of flame when designed and tested in accordance with this Appendix.

1.3 Instruction manual

1.3.1 The manufacturer is to supply a copy of the instruction manual, which is to be kept on board the tanker and which is to include:

- a) installation instructions
- b) operating instructions
- c) maintenance requirements, including cleaning (see [2.3.3])
- d) a copy of the laboratory report referred to in [4.6]
- e) flow test data, including flow rates under both positive and negative pressures, operating sensitivity, flow resistance and velocity.

2 Design of the devices

2.1 Principles

2.1.1 Depending on their service and location, devices are required to protect against the propagation of:

- a) moving flames, and/or
- b) stationary flames from pre-mixed gases after ignition of gases resulting from any cause.

2.1.2 When flammable gases from outlets ignite, the following four situations may occur:

- a) at low gas velocities the flame may:
 - 1) flashback, or
 - 2) stabilise itself as if the outlet were a burner.
- b) at high gas velocities, the flame may:
 - 1) burn at a distance above the outlet, or
 - 2) be blown out.

2.1.3 In order to prevent the passage of flame into a cargo tank, devices are to be capable of performing one or more of the following functions:

- a) permitting the gas to pass through passages without flashback and without ignition of the gases on the protected side when the device is subjected to heating for a specified period;
- b) maintaining an efflux velocity in excess of the flame speed for the gas irrespective of the geometric configuration of the device and without the ignition of gases on the protected side, when the device is subjected to heating for a specified period; and
- c) preventing an influx of flame when conditions of vacuum occur within the cargo tanks.

2.2 Mechanical design

2.2.1 The casing or housing of devices is to meet similar standards of strength, heat resistance and corrosion resistance as the pipe to which it is attached.

2.2.2 The design of devices is to allow for ease of inspection and removal of internal elements for replacement, cleaning or repair.

2.2.3 All flat joints of the housing are to be machined true and are to provide an adequate metal-to-metal contact.

2.2.4 Flame arrester elements are to fit in the housing in such a way that flame cannot pass between the element and the housing.

2.2.5 Resilient seals may be installed only if their design is such that if the seals are partially or completely damaged or burned, the device is still capable of effectively preventing the passage of flame.

2.2.6 Devices are to allow for efficient drainage of moisture without impairing their efficiency to prevent the passage of flame.

2.2.7 The casing, flame arrester element and gasket materials are to be capable of withstanding the highest pressure and temperature to which the device may be exposed under both normal and specified fire test conditions.

2.2.8 End-of-line devices are to be so constructed as to direct the efflux vertically upwards.

2.2.9 Fastenings essential to the operation of the device, i.e. screws, etc., are to be protected against loosening.

2.2.10 Means are to be provided to check that any valve lifts easily without remaining in the open position.

2.2.11 Devices in which the flame arresting effect is achieved by the valve function and which are not equipped with flame arrester elements (e.g. high velocity valves) are to have a width of the contact area of the valve seat of at least 5 mm.

2.2.12 Devices are to be resistant to corrosion in accordance with [4.5.1].

2.2.13 Elements, gaskets and seals are to be of material resistant to both seawater and the cargoes carried.

2.2.14 The casing of the housing is to be capable of passing a hydrostatic pressure test, as required in [4.5.2].

2.2.15 In-line devices are to be able to withstand without damage or permanent deformation the internal pressure resulting from detonation when tested in accordance with [4.4].

2.2.16 A flame arrester element is to be designed to ensure quality control of manufacture to meet the characteristics of the prototype tested, in accordance with this Appendix.

2.3 Performance

2.3.1 Devices are to be tested in accordance with [4.5] and thereafter shown to meet the test requirements of [4.2] to [4.4], as appropriate.

Note 1: End-of-line devices which are intended for exclusive use at openings of inerted cargo tanks need not be tested against endurance burning as specified in [4.2.3].

Note 2: Where end-of-line devices are fitted with cowls, weather hoods and deflectors, etc., these attachments are to be fitted for the tests described in [4.2].

Note 3: When venting to atmosphere is not performed through an end-of-line device according to Note 2, or a detonation flame arrester according to [3.2.2], the in-line device is to be specifically tested with the inclusion of all pipes, tees, bends, cowls, weather hoods, etc., which may be fitted between the device and atmosphere. The testing is to consist of the flashback test in [4.2.2] and, if for the given installation it is possible for a stationary flame to rest on the device, the testing is also to include the endurance burning test in [4.2.3].

2.3.2 Performance characteristics such as the flow rates under both positive and negative pressure, operating sensitivity, flow resistance and velocity are to be demonstrated by appropriate tests.

2.3.3 Devices are to be designed and constructed to minimise the effect of fouling under normal operating conditions. Instructions on how to determine when cleaning is required and the method of cleaning are to be provided for each device in the manufacturer's instruction manual.

2.3.4 Devices are to be capable of operating in freezing conditions and if any device is provided with heating arrangements so that its surface temperature exceeds 85°C, then it is to be tested at the highest operating temperature.

2.3.5 Devices based upon maintaining a minimum velocity are to be capable of opening in such a way that a velocity of 30 m/s is immediately initiated, maintaining an efflux velocity of at least 30 m/s at all flow rates and, when the gas flow is interrupted, closing in such a way that this minimum velocity is maintained until the valve is fully closed.

2.3.6 In the case of high velocity vents, the possibility of inadvertent detrimental hammering leading to damage and/or failure is to be considered, with a view to eliminating it.

Note 1: Hammering is intended to mean a rapid full stroke opening/closing, not foreseen by the manufacturer during normal operations.

2.4 Flame screens

2.4.1 Flame screens are to be:

- a) designed in such a manner that they cannot be inserted improperly in the opening
- b) securely fitted in openings so that flames cannot circumvent the screen
- c) able to meet the requirements of this Appendix. For flame screens fitted at vacuum inlets through which vapours cannot be vented, the test specified in [4.2.3] need not be complied with.
- d) protected against mechanical damage.

2.5 Marking of devices

2.5.1 Each device is to be permanently marked, or have a permanently fixed tag made of stainless steel or other corrosion-resistant material, to indicate:

- a) the manufacturer's name or trade mark
- b) the style, type, model or other manufacturer's designation for the device
- c) the size of the outlet for which the device is approved
- d) the approved location for installation, including maximum or minimum length of pipe, if any, between the device and the atmosphere
- e) the direction of flow through the device
- f) the test laboratory and report number, and
- g) compliance with the requirements of this Appendix.

3 Sizing, location and installation of devices

3.1 Sizing of devices

3.1.1 To determine the size of devices to avoid inadmissible pressure or vacuum in cargo tanks during loading or discharging, calculations of pressure losses are to be carried out.

The following parameters are to be taken into account:

- a) loading/discharge rates
- b) gas evolution
- c) pressure loss through devices, taking into account the resistance coefficient
- d) pressure loss in the vent piping system
- e) pressure at which the vent opens if a high velocity valve is used
- f) density of the saturated vapour/air mixture
- g) possible fouling of a flame arrester; 70% of its rated performance is to be used in the pressure drop calculation of the installation.

3.2 Location and installation of devices

3.2.1 General

- a) Devices are to be located at the vent outlets to atmosphere unless tested and approved for in-line installation.
- b) Devices for in-line installation may not be fitted at the outlets to atmosphere unless they have also been tested and approved for that position.

3.2.2 Detonation flame arresters

Where detonation flame arresters are installed as in-line devices venting to atmosphere, they are to be located at a sufficient distance from the open end of the pipeline so as to preclude the possibility of a stationary flame resting on the arrester.

3.2.3 Access to the devices

Means are to be provided to enable personnel to reach devices situated more than 2 m above deck to facilitate maintenance, repair and inspection.

4 Type test procedures

4.1 Principles

4.1.1 Tests are to be conducted by a laboratory acceptable to the Society.

4.1.2 Each size of each model is to be submitted for type testing. However, for flame arresters, testing may be limited to the smallest and the largest sizes and one additional size in between to be chosen by the Society. Devices are to have the same dimensions and most unfavourable clearances expected in the production model. If a test device is modified during the test program, the testing is to be restarted.

4.1.3 Tests described in this Article using gasoline vapours (a non-leaded petroleum distillate consisting essentially of aliphatic hydrocarbon compounds with a boiling range approximating 65°C - 75°C), technical hexane vapours or technical propane, as appropriate, are suitable for all devices protecting tanks containing a flammable atmosphere of the cargoes referred to in [1.1.1]. This does not preclude the use of gasoline vapours or technical hexane vapours for all tests referred to in this Article.

4.1.4 After the relevant tests, the device is not to show mechanical damage that affects its original performance.

4.1.5 Before the tests the following equipment, as appropriate, is to be properly calibrated:

- a) gas concentration meters
- b) thermometers
- c) flow meters
- d) pressure meters, and
- e) time recording devices.

4.1.6 The following characteristics are to be recorded, as appropriate, throughout the tests:

- a) concentration of fuel in the gas mixture
- b) temperature of the test gas mixture at inflow of the device, and
- c) flow rates of the test gas mixtures when applicable.

4.1.7 Flame passage is to be observed by recording, e.g. temperature, pressure, or light emission, by suitable sensors on the protected side of the device; alternatively, flame passage may be recorded on video tape.

4.2 Test procedure for flame arresters located at openings to the atmosphere

4.2.1 Test rig

The test rig is to consist of an apparatus producing an explosive mixture, a small tank with a diaphragm, a flanged prototype of the flame arrester, a plastic bag and a firing source in three positions (see Fig 1). Other test rigs may be used, provided the tests referred to in this Article are carried out to the satisfaction of the Society.

Figure 1 : Test rig for flashback test

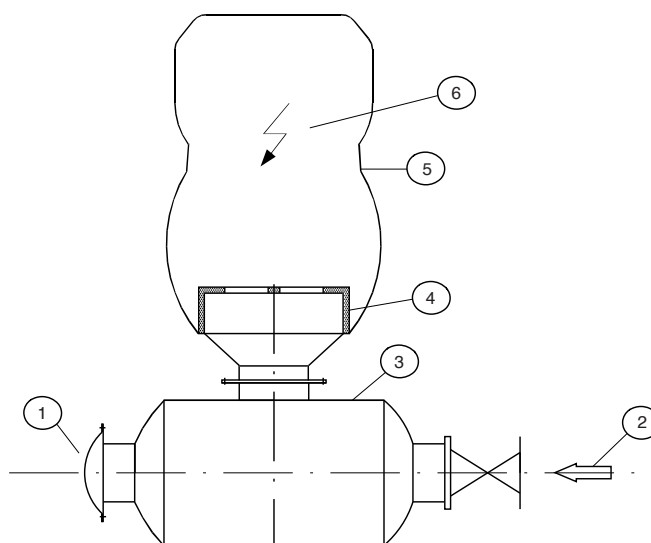

- (1): Plastic bursting diaphragm
- (2): Explosive mixture inlet
- (3): Tank
- (4): Flame arresting device
- (5): Plastic bag
- (6): Ignition source

Note 1: The dimensions of the plastic bag are dependent on those of the flame arrester, but for flame arresters normally used on tankers the plastic bag may have a circumference of 2 m, a length of 2,5 m and a wall thickness of 0,05 mm.

Note 2: In order to avoid remnants of the plastic bag from falling back on to the device being tested after ignition of the fuel/air mixture, it may be useful to mount a coarse wire frame across the device within the plastic bag. The frame is to be so constructed as not to interfere with the test result.

4.2.2 Flashback test

A flashback test is to be carried out as follows:

a) The tank, flame arrester assembly and the plastic bag (see [4.2.1]) enveloping the prototype flame arrester are to be filled so that this volume contains the most easily ignitable propane/air mixture (see IEC Publication 79/1).

The concentration of the mixture is to be verified by appropriate testing of the gas composition in the plastic bag. Where devices referred to in [2.3.1], Note 3 are tested, the plastic bag is to be fitted at the outlet to atmosphere. Three ignition sources are to be installed along the axis of the bag, one close to the flame arrester, another as far away as possible therefrom, and the third at the mid-point between these two. These three sources are to be fired in succession, twice in each of the three positions. The temperature of the test gas is to be within the range of 15°C to 40°C.

b) If a flashback occurs, the tank diaphragm will burst and this will be audible and visible to the operator by the emission of a flame. Flame, heat and pressure sensors may be used as an alternative to a bursting diaphragm.

Figure 2 : Schematic Plan of the Test Plant for High Velocity Valves (endurance burning test only)

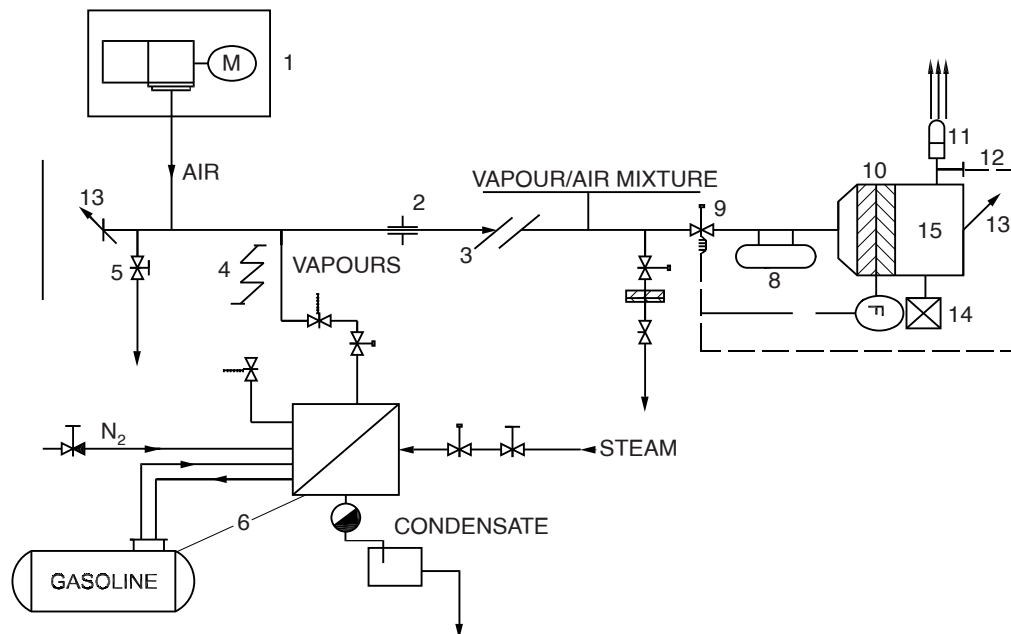

- (1): Fan with variable speed
- (2): Volume rate indicator
- (3): Pipe (diameter=500 mm, length=30 m)
- (4): Heated vapour pipe
- (5): Air bypass
- (6): Evaporator and gasoline storage tank
- (7): Vapour/air mixture bypass
- (8): Extinguishing agents
- (9): Automatic control and quick action stop valve
- (10): Explosion arresting crimped ribbon with temperature sensors for the safety of the test rig
- (11): High velocity valve to be tested
- (12): Flame detector
- (13): Bursting diaphragm
- (14): Concentration indicator
- (15): Tank

4.2.3 Endurance burning test

An endurance burning test is to be carried out, in addition to the flashback test, for flame arresters at outlets where flows of explosive vapour are foreseeable:

- The test rig as referred to in [4.2.1] may be used, without the plastic bag. The flame arrester is to be so installed that the mixture emission is vertical. In this position the mixture is to be ignited. Where devices referred to in [2.3.1], Note 3, are tested, the flame arrester is to be so installed as to reflect its final orientation.
- Endurance burning is to be achieved by using the most easily ignitable gasoline vapour/air mixture or the most easily ignitable technical hexane vapour/air mixture with the aid of a continuously operated pilot flame or a continuously operated spark igniter at the outlet. The test gas is to be introduced upstream of the tank shown in Fig 1. Maintaining the concentration of the mixture as specified above, by varying the flow rate, the flame arrester is to be heated until the highest obtainable temperature on the cargo tank side of the arrester is reached. Temperatures are to be measured, for example, at the protected side of the flame quenching matrix of the arrester (or at the seat of the valve in the case of testing high velocity vents according to [4.3]). The highest

obtainable temperature may be considered to have been reached when the rate of rise of temperature does not exceed 0,5°C per minute over a ten-minute period. This temperature is to be maintained for a period of ten minutes, after which the flow is to be stopped and the conditions observed. The temperature of the test gas is to be within the range of 15°C to 40°C.

If no temperature rise occurs at all, the arrester is to be inspected for a more adequate position of the temperature sensor, taking account of the visually registered position of the stabilised flame during the first test sequence. Positions which require the drilling of small holes into fixed parts of the arrester are to be taken into account. If all this is not successful, the temperature sensor is to be affixed at the unprotected side of the arrester in a position near to the stabilised flame.

If difficulties arise in establishing stationary temperature conditions (at elevated temperatures), the following criterion is to apply: using the flow rate which produced the maximum temperature during the foregoing test sequence, endurance burning is to be continued for a period of two hours from the time the above-mentioned flow rate has been established. After that period the flow is to be stopped and the conditions observed. Flashback is not to occur during this test.

Figure 3 : Test Rig for High Velocity Vents

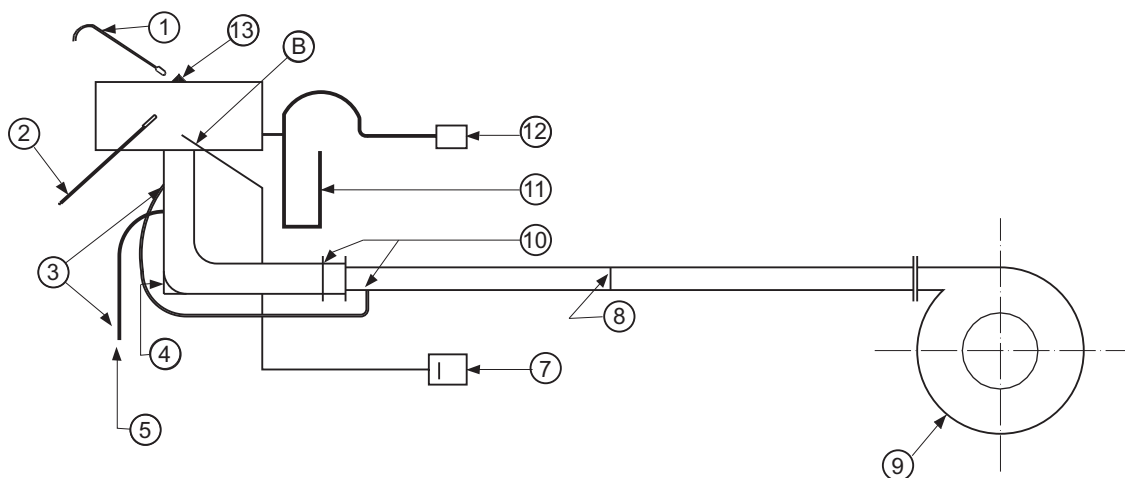

- (1): Primary igniter
- (2): Secondary igniter
- (3): Cocks
- (4): Explosion door
- (5): Gas supply
- (6): Flashback detector
- (7): Chart recorder
- (8): Flow meter
- (9): Fan
- (10): Spade blank and bypass line for low rates
- (11): Pressure gauge
- (12): Gas analyser
- (13): High velocity vent to be tested

4.2.4 Pressure/vacuum valve integrated to a flame arresting device

When a pressure/vacuum valve is integrated to a flame arresting device, the flashback test is to be performed with the pressure/ vacuum valve blocked open. If there are no additional flame quenching elements integrated in a pressure valve, this valve is to be considered and tested as a high velocity vent valve according to [4.3].

4.3 Test procedures for high velocity vents

4.3.1 Test rig

The test rig is to be capable of producing the required volume flow rate. In Fig 2 and Fig 3 drawings of suitable test rigs are shown. Other test rigs may be used provided the tests are performed to the satisfaction of the Society.

4.3.2 Flow condition test

A flow condition test is to be carried out with high velocity vents using compressed air or gas at agreed flow rates. The following are to be recorded:

- a) the flow rate; where air or a gas other than vapours of cargoes with which the vent is to be used is employed in the test, the flow rates achieved are to be corrected to reflect the vapour density of such cargoes
- b) the pressure before the vent opens; the pressure in the test tank on which the device is located is not to rise at a rate greater than 0,01 MPa/min
- c) the pressure at which the vent opens
- d) the pressure at which the vent closes
- e) the efflux velocity at the outlet which is not to be less than 30 m/s at any time when the valve is open.

4.3.3 Fire safety tests

The following fire safety tests are to be conducted while adhering to [2.3.6] using a mixture of gasoline vapour and air or technical hexane vapour and air, which produces the most easily ignitable mixture at the point of ignition. This mixture is to be ignited with the aid of a permanent pilot flame or a spark igniter at the outlet.

- a) Flashback tests in which propane may be used instead of gasoline or hexane are to be carried out with the vent in the upright position and then inclined at 10° from the vertical. For some vent designs further tests with the vent inclined in more than one direction may be necessary. In each of these tests the flow is to be reduced until the vent closes and the flame is extinguished, and each is to be carried out at least 50 times. The vacuum side of combined valves is to be tested in accordance with [4.2.2] with the vacuum valve maintained in the open position for the duration of this test, in order to verify the efficiency of the device which is to be fitted.
- b) An endurance burning test, as described in [4.2.3], is to be carried out. Following this test, the main flame is to be extinguished and then, with the pilot flame burning or the spark igniter discharging, small quantities of the most easily ignitable mixture are to be allowed to escape for a period of ten minutes maintaining a pres-

sure below the valve of 90% of the valve opening setting, during which time flashback is not to occur. For the purpose of this test the soft seals or seats are to be removed.

4.4 Test rig and test procedures for detonation flame arresters located in-line

4.4.1 A flame arrester is to be installed at one end of a pipe of suitable length and of the same diameter as the flange of the flame arrester. On the opposed flange a pipe of a length corresponding to 10 pipe diameters is to be affixed and closed by a plastic bag or diaphragm. The pipe is to be filled with the most easily ignitable mixture of propane and air, which is then to be ignited. The velocity of the flame near the flame arrester is to be measured and is to have the same value as that for stable detonations.

Note 1: The dimensions of the plastic bag are to be at least 4 m circumference, 4 m length and a material wall thickness of 0,05 mm.

4.4.2 Three detonation tests are to be conducted, no flashback is to occur through the device and no part of the flame arrester is to be damaged or show permanent deformation.

4.4.3 Other test rigs may be used provided the tests are carried out to the satisfaction of the Society. A drawing of the test rig is shown in Fig 4.

4.5 Operational test procedure

4.5.1 Corrosion test

A corrosion test is to be carried out. In this test a complete device, including a section of the pipe to which it is fitted, is to be exposed to a 5% sodium chloride solution spray at a temperature of 25°C for a period of 240 hours, and allowed to dry for 48 hours. An equivalent test may be conducted to the satisfaction of the Society. Following this test, all movable parts are to operate properly and there are to be no corrosion deposits which cannot be washed off.

4.5.2 Hydraulic pressure test

A hydraulic pressure test is to be carried out in the casing or housing of a sample device, in accordance with [2.2.15].

4.6 Laboratory report

4.6.1 The laboratory report is to include:

- a) detailed drawings of the device
- b) types of tests conducted; where in-line devices are tested, this information is to include the maximum pressures and velocities observed in the test
- c) specific advice on approved attachments
- d) types of cargo for which the device is approved
- e) drawings of the test rig
- f) in the case of high velocity vents, the pressures at which the device opens and closes and the efflux velocity, and
- g) all the information marked on the device in [2.5].

Figure 4 : Test Rig for Arresters Located In-Line

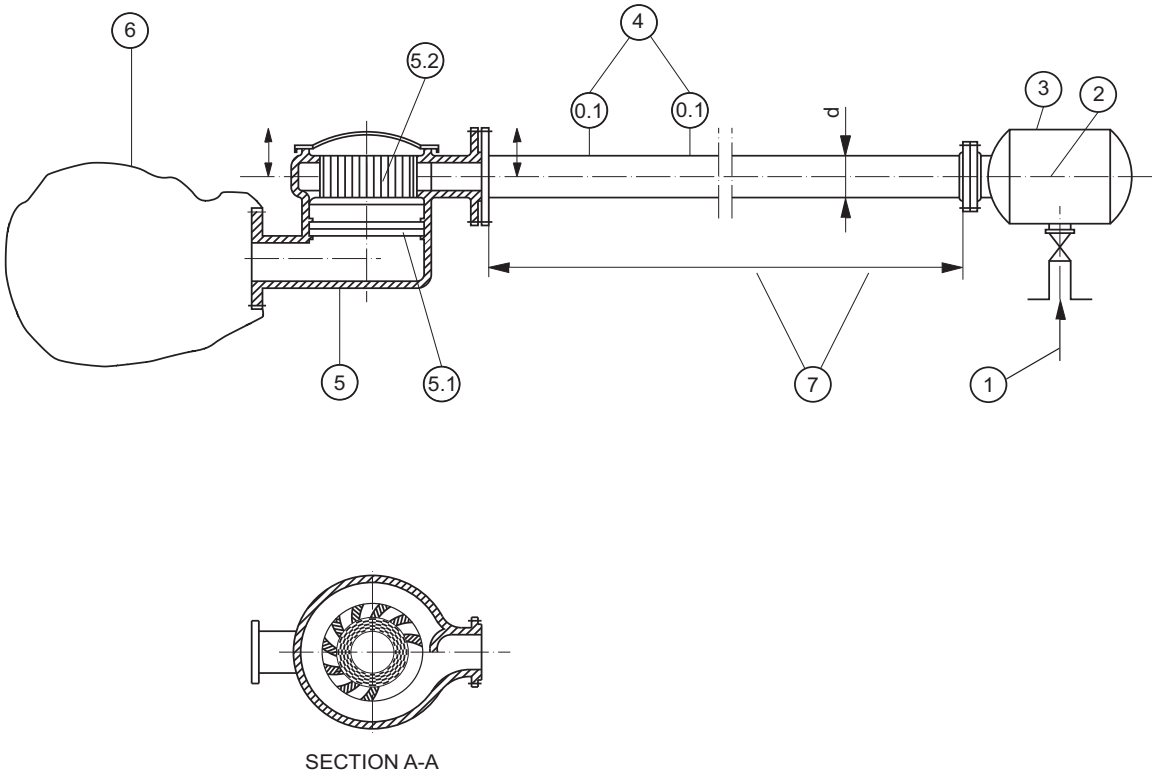

- (1): Explosive mixture inlet
- (2): Ignition source; ignition within non-streaming mixture
- (3): Tank
- (4): Measuring system for flame speed of a stable detonation
- (5): Flame arrester located in-line; (5.1): Flame arrester element; (5.2): Shock wave absorber
- (6): Plastic bag
- (7): $l/d = 100$

APPENDIX 2

DESIGN OF CRUDE OIL WASHING SYSTEMS

1 General

1.1 Application

1.1.1 This Appendix applies to FPSO provided with crude oil washing system for cargo tank cleaning.

2 Design and installation

2.1 Piping

2.1.1 The crude oil washing pipes and all valves incorporated in the supply piping system are to be of steel or other equivalent material, of adequate strength having regard to the pressure to which they may be subjected, and properly jointed and supported.

Note 1: Grey cast iron may be permitted in the supply system for crude oil washing systems when complying with nationally approved standards.

The crude oil washing system is to consist of permanent pipework and is to be independent of the fire mains and of any system other than for tank washing except that sections of the unit's cargo system may be incorporated into the crude oil washing system provided that they meet the requirements applicable to crude oil pipework.

2.1.2 Provisions are to be made to prevent overpressure in the tank washing supply piping. Any relief device fitted to prevent overpressure is to discharge into the suction side of the supply pump. Alternative methods to the satisfaction of the Society may be accepted provided an equivalent degree of safety and environmental protection is provided.

Note 1: Where the system is served only by centrifugal pumps so designed that the pressure derived cannot exceed that for which the piping is designed, a temperature sensing device located in the pump casing is required to stop the pump in the case of overheating.

2.1.3 Where hydrant valves are fitted for water washing purposes on tank washing lines, all such valves are to be of adequate strength and provisions are to be made for such connections to be blanked off by blank flanges when washing lines may contain crude oil. Alternatively, hydrant valves are to be isolated from the crude oil washing system by spade blanks.

2.1.4 All connections for pressure gauges or other instrumentation are to be provided with isolating valves adjacent to the lines unless the fitting is of the sealed type.

2.1.5 No part of the crude oil washing system is to enter machinery spaces. Where the tank washing system is fitted with a steam heater for use when water washing, the heater

is to be located outside machinery spaces and effectively isolated during crude oil washing by double shut-off valves or by clearly identifiable blanks.

2.1.6 Where combined crude oil-water washing supply piping is provided, the piping is to be so designed that it can be drained so far as practicable of crude oil, before water washing is commenced, into designated spaces. These spaces may be the slop tank or other cargo spaces.

2.1.7 The crude oil washing supply piping is to be anchored (firmly attached) to the unit's structure at appropriate locations, and means are to be provided to permit freedom of movement elsewhere to accommodate thermal expansion and flexing of the unit. The anchoring is to be such that any hydraulic shock can be absorbed without undue movement of the supply piping. The anchors are normally to be situated at the ends furthest from the entry of the crude oil supply to the supply piping. If tank washing machines are used to anchor the ends of branch pipes then special arrangements are necessary to anchor these sections when the machines are removed for any reason.

2.2 Tank washing machines

2.2.1 Tank washing machines for crude oil washing are to be permanently mounted and of a design acceptable to the Society. Where a machine is positioned well below the deck level to cater for protuberances in the tank, consideration may need to be given to additional support for the machine and its supply piping.

2.2.2 Each machine is to be capable of being isolated by means of stop valves in the supply line. If a deck mounted tank washing machine is removed for any reason, provision is to be made to blank off the oil supply line to the machine for the period the machine is removed. Similarly, provision is to be made to close the tank opening with a plate or equivalent means.

2.3 Pumps

2.3.1 Pumps supplying crude oil to tank cleaning machines are to be either the cargo pumps or pumps specifically provided for the purpose.

2.4 Ballast lines

2.4.1 Where a separate ballast water system for ballasting cargo tanks is not provided, the arrangement is to be such that the cargo pump, manifolds and pipes used for ballasting can be safely and effectively drained of oil before ballasting.

3 Testing

3.1 Piping

3.1.1 The crude oil washing piping is to be tested at one and half time the design pressure after it has been installed on the unit.

SECTION 1	GENERAL
SECTION 2	STABILITY
SECTION 3	UNIT ARRANGEMENT
SECTION 4	CARGO CONTAINMENT
SECTION 5	REGASIFICATION SYSTEMS, PROCESS PRESSURE VESSELS AND LIQUID, VAPOUR AND PRESSURE PIPING SYSTEMS
SECTION 6	MATERIALS FOR CONSTRUCTION
SECTION 7	CARGO PRESSURE/TEMPERATURE CONTROL
SECTION 8	CARGO TANK VENTING SYSTEM
SECTION 9	ENVIRONMENTAL CONTROL
SECTION 10	ELECTRICAL INSTALLATIONS
SECTION 11	SAFETY SYSTEM AND FIRE PROTECTION
SECTION 12	MECHANICAL VENTILATION IN THE CARGO AREA
SECTION 13	INSTRUMENTATION (GAUGING, GAS DETECTION)
SECTION 14	PROTECTION OF PERSONNEL
SECTION 15	FILLING LIMITS FOR CARGO TANKS
SECTION 16	USE OF CARGO AS FUEL
SECTION 17	SPECIAL REQUIREMENTS
SECTION 18	OPERATING REQUIREMENTS
SECTION 19	SUMMARY OF MINIMUM REQUIREMENTS

SECTION 1

GENERAL

1 Scope

1.1 Applicability

1.1.1 IGC Code requirements and the Society's Rules

- a) These units are to comply with the requirements of the latest version of the International Code for the Construction and Equipment of Ships Carrying Liquefied Gases in Bulk, as amended. In these Rules reference to this Code and its amendments is made by the wording "IGC Code".

Accordingly, for units for which the service notation **FSRU**, in accordance with Pt A, Ch 1, Sec 2, [4.4.1], is requested, the IGC Code requirements are to be considered as rule requirements, with the exception indicated in [1.1.2].

- b) The requirements of this Chapter supplement those of the IGC Code, as amended. These requirements include additional mandatory class requirements, as well as the Society's interpretations of the IGC Code, which are also to be considered mandatory for class.
- c) This Chapter and the IGC Code refer to units storing those products which are listed in the table in Chapter 19 of the IGC Code and in Section 19 of this Chapter, as applicable to FSRU.
- d) This Chapter and the IGC Code include requirements for the storage of cargo in containment systems incorporating integral, membrane or independent tank types as detailed in Chapter 4 of the IGC Code and in Sec 4.
- e) In general, this Chapter applies to cargo containment and handling systems and to the interfaces between these systems and the remainder of the unit, which is to comply with the applicable Sections of the hull and machinery Rules.

1.1.2 IGC Code requirements not within the scope of classification

The following requirements of the IGC Code are not within the scope of classification:

- Chapter 1, Section 1.4 - Equivalents
- Chapter 1, Section 1.5 - Surveys and certification
- Chapter 2, Section 2.4 - Condition of loading
- Chapter 2, Section 2.5 - Damage assumption
- Chapter 2, Section 2.7 - Flooding assumption
- Chapter 2, Section 2.8 - Standard of damage
- Chapter 2, Section 2.9 - Survival requirements
- Chapter 11 - Fire protection and fire extinction
- Chapter 14 - Personnel protection
- Chapter 18 - Operating requirements.

These requirements are applied by the Society when acting on behalf of the flag Administration, within the scope of delegation.

1.1.3 Storage of products not listed in the Code

The requirements of the IGC Code and the additional requirements of this Chapter are also applicable to new products, which may be considered to come within the scope of these rules, but are not at present listed in the table in Chapter 19 of the IGC Code.

1.1.4 Particularly hazardous products

For the storage in bulk of products which are not listed in the table in Chapter 19 of the IGC Code, presenting more severe hazards than those covered by the IGC Code, the Society reserves the right to establish requirements and/or conditions additional to those contained in these rules.

1.1.5 Correspondence of the IGC Code with this Chapter

All the requirements of this Chapter are cross referenced to the applicable Chapters, Sections or paragraphs of the IGC Code, as appropriate.

1.1.6 Equivalencies

As far as the requirements for class are concerned, the following wording in the IGC Code is to be given the meanings indicated in Tab 1.

Table 1

IGC Code word	Meaning for Classification only
Administration	Society
Recognised Standard	Rules
should be	is to be or are to be (as applicable)

2 Documentation to be submitted

2.1

2.1.1 Tab 2 lists the plans, information, analysis, etc. which are to be submitted in addition to the information required in the other Parts of the Rules for the parts of the unit not affected by the cargo, as applicable.

3 Cargo equipment trials

3.1 Scope

3.1.1 Trials in working conditions

All the equipment to which this Chapter is applicable is to be tested in actual working conditions. See also Sec 4, [13.4].

3.1.2 Trials to be carried out

Those trials which may only be carried out when the unit is loaded are to be held at the first operation of the unit.

3.2 Extent of the tests**3.2.1 Cargo equipment testing procedure**

The cargo equipment testing procedure is to be submitted to the Society for review.

3.2.2 Use of cargo as fuel

The arrangements for using cargo as fuel are to be subjected to a special testing procedure.

Table 2 : Documents to be submitted

No	A/I	Documents
1	I	List of products to be carried, including maximum vapour pressure, maximum liquid temperature and other important design conditions
2	I	General arrangement plan, showing location of cargo tanks and fuel oil, ballast and other tanks
3	A	Gas-dangerous zones plan
4	A	Location of void spaces and accesses to dangerous zones
5	A	Air locks between safe and dangerous zones
6	A	Ventilation duct arrangement in gas-dangerous spaces and adjacent zones
7	A	Details of hull structure in way of cargo tanks, including support arrangement for tanks, saddles, anti-floating and anti-lifting devices, deck sealing arrangements, etc.
8	A	Calculation of the hull temperature in all the design cargo conditions
9	A	Distribution of quality and steel grades in relation to the contemplated actual temperature obtained by the calculation in item 8
10	A	Hull stress analysis
11	A	Hull unit motion analysis, where a direct analysis is preferred to the methods indicated in Sec 4
12	A	Intact and damage stability calculations
13	A	Scantlings, material and arrangement of the cargo containment system, including the secondary barrier, if any.
14	A	Stress analysis of the cargo tanks, including fatigue analysis and crack propagation analysis for type "B" tanks. This analysis may be integrated with that indicated in item 10
15	I	Calculation of the thermal insulation suitability, including boil-off rate and refrigeration plant capability, if any, cooling down and temperature gradients during loading and unloading operations
16	A	Details of insulation
17	A	Details of ladders, fittings and towers in tanks and relative stress analysis, if any
18	A	Details of tank domes and deck sealings
19	A	Plans and calculations of safety relief valves
20	A	Details of cargo handling and vapour system, including arrangements and details of piping and fitting
21	A	Details of cargo pumps and cargo compressors
22	A	Details of process pressure vessels and relative valving arrangement
23	A	Bilge and ballast system in cargo area
24	A	Gas freeing system in cargo tanks including inert gas system
25	A	Interbarrier space drainage, inerting and pressurisation systems
26	A	Ventilation system in cargo area
27	A	Hull structure heating system, if any
Note 1: A = to be submitted for approval in four copies I = to be submitted for information in duplicate		

No	A/I	Documents
28	A	Regasification system
29	A	Documents giving details of type of cables and safety characteristics of the equipment installed in hazardous areas
30	A	Schematic electrical wiring diagram in cargo area
31	A	Gas detection system
32	A	Cargo tank instrumentation, including cargo diagrams of tank level indicator systems, high level alarm systems and hull temperature monitoring system
33	A	Emergency shutdown system
34	A	Jettison system, if any
35	A	Details of fire-extinguishing appliances and systems in cargo area
36	A	Loading and unloading operation description, including cargo tank filling limits
37	A	Cargo tank testing and inspection procedures
38		For machinery using gas as fuel I a) General arrangement plan of the machinery plant I b) Description of the entire plant A c) Gas piping plans for the machinery plant A d) Complete list of the safety, gas detection and warning equipment A e) Drawings of the boilers I f) Detailed drawings of the gas inlet and fuel inlet equipment I g) Gas characteristics A h) General arrangement plan of the gas treatment plant, including gas compressors, prime movers and gas preheaters A i) Drawings of the gas storage tanks A j) Drawings of the gas compressors and preheaters
Note 1:		A = to be submitted for approval in four copies I = to be submitted for information in duplicate

SECTION 2

STABILITY

1 General

1.1

1.1.1

IGC CODE REFERENCE : Ch 2

This Section applies in addition to the requirements set out in Part B, Chapter 3.

2 Intact stability

2.1 General requirements

IGC CODE REFERENCE : Ch 2, 2.2.2

2.1.1 In each loading condition the following is to be satisfied:

- a) the initial metacentric height, calculated by taking into account the influence of the free surfaces, is to be not less than 0,15 m
- b) the diagrams of the stability arms are to confirm the following requisites:
 - 1) the arm of maximum stability G_{zmax} is to correspond to a transverse heeling angle preferably greater than 30° but in any case not less than 25° ;
 - 2) the arm of stability GZ is to be not less than 0,20 m with a transverse heeling angle θ not less than 30° ;
 - 3) the area below the stability diagram is to be not less than 0,055 m * rad for heeling angles θ from 0° to 30° and not less than 0,09 m * rad for heeling angles θ from 0° to 40° or to θ_f if the latter is less than 40° .

The heeling angle θ_f is that which corresponds to the intake of water and therefore defines where the stability curve is to be considered broken.

In addition to the above, the area below the stability diagram is to be not less than 0,030 m * rad, for heeling angles from 30° to 40° or from 30° to θ_f , if θ_f is less than 40°

- c) the provisions of the following paragraphs are to be checked in relation to the action of the wind.

2.2 Weather criterion

IGC CODE REFERENCE : Ch 2, 2.2.2

2.2.1 The curves are to be traced of the righting and heeling moments due to the transverse wind similar to those shown in Fig 1, together with the relevant calculations, taking into account the maximum cargo on the deck and the equipment placed in the most unfavourable position. The effect of the free surfaces in the tanks is to be taken into account.

2.2.2 If there are structural fittings which can be dismantled and stowed, further curves of the heeling moment due to the wind may be requested and the relevant documentation is to clearly indicate the position of these fittings.

2.2.3 When calculating the righting moment, any possible negative effects due to the presence of the mooring system are to be taken into account.

2.2.4 As regards the calculation of the forces and heeling moment due to the wind, reference is made to the relevant provisions of Ch 4, Sec 3, [3.1] of these Rules.

In particular, for the wind speed, the characteristic value of the site corresponding to a recurring period of 100 years or the speed of 51,5 m/s (100 knots) is to be assumed, whichever is the greater.

For sites situated in protected zones, the Society reserves the right to accept a wind speed less than 51,5 m/s.

2.2.5 The stability of a unit is to satisfy the criteria stated under the following items (a) and (b) (see also Fig 1):

- a) The ratio of the area under the righting moment curve to that under the heeling moment curve up to the angle in way of the second intercept or up to the downflooding angle θ_f , whichever is the lesser, is to be not less than 1,4.
- b) The righting moment curve is to be positive over the entire range of angles up to the angle in way of the second intercept.

2.2.6 Each unit is to be capable of attaining a severe storm condition in a period of time consistent with the meteorological conditions. The procedures recommended and the approximate length of time required, considering both operating conditions and transit conditions, are to be contained in the Operating Manual.

It is to be possible to achieve the severe storm condition without the removal or relocation of solid consumables or other variable load. However, the Society may permit loading a unit past the point at which solid consumables would have to be removed or relocated to attain the severe storm condition under the following conditions, provided the allowable KG requirement is not exceeded:

- a) in a geographic location where weather conditions annually or seasonally do not become sufficiently severe to require a unit to go to severe storm conditions, or
- b) where a unit is required to support extra deckload for a short period of time that falls well within a period for which the weather forecast is favourable.

The geographic locations, weather conditions and loading conditions in which this is permitted are to be identified in the Operating Manual.

2.3 Alternative stability criteria

IGC CODE REFERENCE : Ch 2, 2.2.2

2.3.1 Alternative stability criteria may be considered by the Society provided an equivalent level of safety is maintained and it is demonstrated that they afford adequate positive initial stability.

3 Location of cargo tanks

3.1 Deck cargo tanks

3.1.1

IGC CODE REFERENCE : Ch 2, 2.6.1

Deck cargo tanks are to be located not less than 760 mm inboard from the side shell.

Figure 1 : Righting moment and heeling moment curves

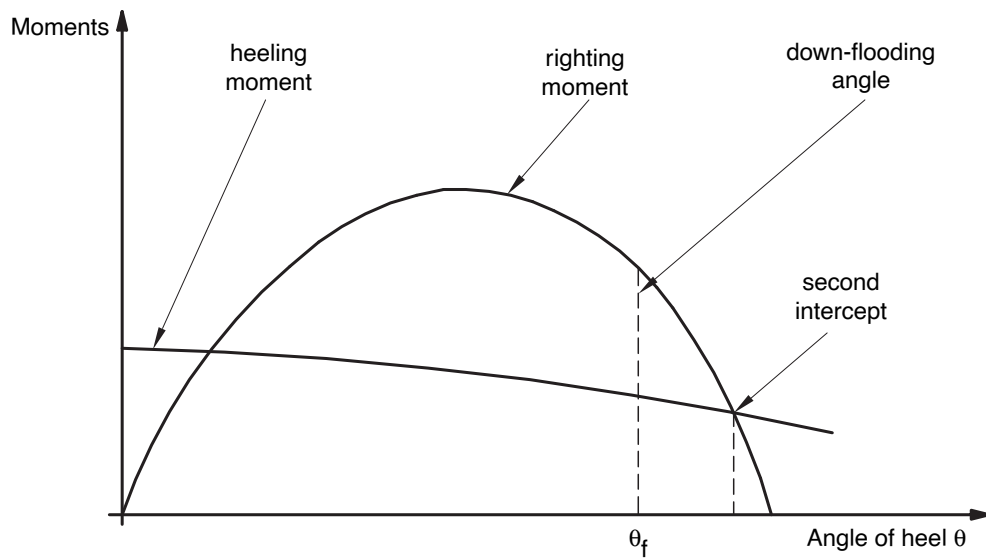

SECTION 3

UNIT ARRANGEMENT

1 Segregation of the cargo area

1.1 Segregation of hold spaces

1.1.1 Bow thruster location

IGC CODE REFERENCE : Ch 3, 3.1.1

Bow thrusters are allowed to be fitted forward of the hold spaces.

1.2 Cargo containment systems not requiring secondary barriers

1.2.1 Separation between cargo spaces

IGC CODE REFERENCE : Ch 3, 3.1.2

Hold spaces may be separated from each other by single bulkheads. Where cofferdams are used instead of single bulkheads, they may be used as ballast tanks subject to special approval by the Society.

1.3 Cargo containment systems requiring secondary barriers

1.3.1 Separation between cargo spaces

IGC CODE REFERENCE : Ch 3, 3.1.3

The requirement in [1.2.1] is applicable.

2 Accommodation, service and machinery spaces and control stations

2.1 General

2.1.1 Precautions against hazardous vapours

IGC CODE REFERENCE : Ch 3, 3.2.2

Compliance with the relevant requirements of the IGC Code, in particular with 3.2.4, 3.8, 8.2.10 and 12.1.6, as applicable, also ensures compliance with the requirements in IGC Code 3.2.2, relevant to precautions against hazardous vapours.

2.1.2 Spaces located forward of the cargo area

IGC CODE REFERENCE : Ch 3, 3.2.4

Entrances and openings to service spaces located forward of the cargo area may not face such area.

2.1.3 Air outlets

IGC CODE REFERENCE : Ch 3, 3.2.4

The requirements in IGC Code 3.2.4, relevant to air intakes, are also intended to be applicable to air outlets. This interpretation also applies to the requirements in IGC Code 3.2.2, 3.8.4 and 8.2.10.

2.1.4 Doors facing cargo area

IGC CODE REFERENCE : Ch 3, 3.2.4

Doors facing the cargo area or located in prohibited zones in the sides are to be restricted to stores for cargo-related and safety equipment, cargo control stations as well as decontamination showers and eye wash.

Where such doors are permitted, the space may not give access to other spaces covered in IGC Code 3.2.4 and the common boundaries with these spaces are to be insulated with A60 class bulkheads.

2.1.5 Exemptions, ventilation openings and type of closures

IGC CODE REFERENCE : Ch 3, 3.2.6

The requirement for fitting air intakes and openings with closing devices operable from inside the space in units intended to storage toxic products is to apply to spaces which are used for the unit's radio and main navigating equipment, cabins, mess rooms, toilets, hospitals, galleys, etc., but does not apply to spaces not normally manned such as deck stores, forecandle stores and workshops. The requirement does not apply to cargo control rooms located within the cargo area.

When internal closing is required, this is to include both ventilation intakes and outlets.

The closing devices are to give a reasonable degree of gas-tightness. Ordinary steel fire-flaps without gaskets/seals are normally not considered satisfactory.

2.1.6 Openings for removal of machinery

IGC CODE REFERENCE : Ch 3, 3.2.6

Bolted plates of A60 class for removal of machinery may be accepted on bulkheads facing cargo areas, provided signboards are fitted to warn that these plates may only be opened when the unit is in gas-free condition.

3 Cargo pump rooms and cargo compressor rooms

3.1 Location of cargo pump rooms and cargo compressor rooms

3.1.1 Single failure concept

IGC CODE REFERENCE : Ch 3, 3.3

When cargo pump rooms and compressor rooms are permitted to be fitted at the after end of the aftermost hold space, the bulkhead which separates the cargo pump rooms or compressor rooms from accommodation and service spaces, control stations and machinery spaces of category A is to be so located as to avoid the entry of gas to these spaces through a single failure of a deck or bulkhead. The same condition is also to be satisfied when cargo pump

rooms and compressor rooms fitted within the cargo area have a bulkhead in common with accommodation and service spaces, control stations and machinery spaces of category A.

3.1.2 Electrical equipment in cargo pump rooms and cargo compressor rooms

IGC CODE REFERENCE: Ch 3, 3.3

Cargo pump rooms and/or cargo compressor rooms of units storing flammable gases may not contain electrical equipment, except as provided for in Chapter 10 of the IGC Code, or other ignition sources such as internal combustion engines or steam engines with operating temperature which could cause ignition or explosion of mixtures of such gases, if any, with air.

4 Access arrangement

4.1 Access to compartments in the cargo area

4.1.1 General

IGC CODE REFERENCE : Ch 3, 3.5

Designated passageways below and above cargo tanks are to have at least the cross-sections as specified in IGC Code 3.5.3.1.

4.1.2 Passage through cargo tanks

IGC CODE REFERENCE : Ch 3, 3.5

For the purpose of the requirements in IGC Code 3.5.1 and 3.5.2, the following applies:

- Where the Surveyor needs to pass between the flat or curved surface to be inspected and structural elements such as deck beams, stiffeners, frames, girders etc., the distance between that surface and the free edge of the structural elements is to be at least 380 mm. The distance between the surface to be inspected and the surface to which the above structural elements are fitted, e.g. deck, bulkhead or shell, is to be at least 450 mm in the case of a curved tank surface (e.g. type C-tank) or 600 mm in case of a flat tank surface (e.g. type A-tank) (see Fig 1).

Figure 1 : Minimum passage over cargo tanks

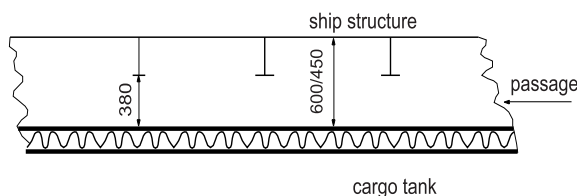

- Where the Surveyor does not need to pass between the surface to be inspected and any part of the structure, for visibility reasons the distance between the free edge of that structural element and the surface to be inspected is to be at least 50 mm or half the breadth of the structure's face plate, whichever is the greater (see Fig 2).

Figure 2 : Minimum distance of structures from cargo tank to allow visual inspection

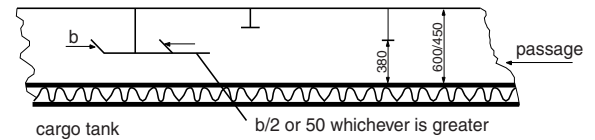

- If for inspection of a curved surface the Surveyor needs to pass between that surface and another flat or curved surface, to which no structural elements are fitted, the distance between both surfaces is to be at least 380 mm (see Fig 3). Where the Surveyor does not need to pass between a curved surface and another surface, a smaller distance than 380 mm may be accepted taking into account the shape of the curved surface.
- If for inspection of an approximately flat surface the Surveyor needs to pass between two approximately flat and approximately parallel surfaces, to which no structural elements are fitted, the distance between those surfaces is to be at least 600 mm (see Fig 4).
- The minimum distances between a cargo tank sump and adjacent double bottom structure in way of a suction well may not be less than that defined in Fig 5. If there is no suction well, the distance between the cargo tank sump and the inner bottom may not be less than 50 mm.
- The distance between a cargo tank dome and deck structures may not be less than 150 mm (see Fig 6).
- Where necessary for inspection, fixed or portable staging is to be installed. This staging may not impair the distances specified in IGC Code 3.5.3.
- Where fixed or portable ventilation ducting is to be fitted in compliance with IGC Code 12.2, such ducting may not impair the distances specified in IGC Code 3.5.3.

Figure 3 : Minimum passage between curved surfaces

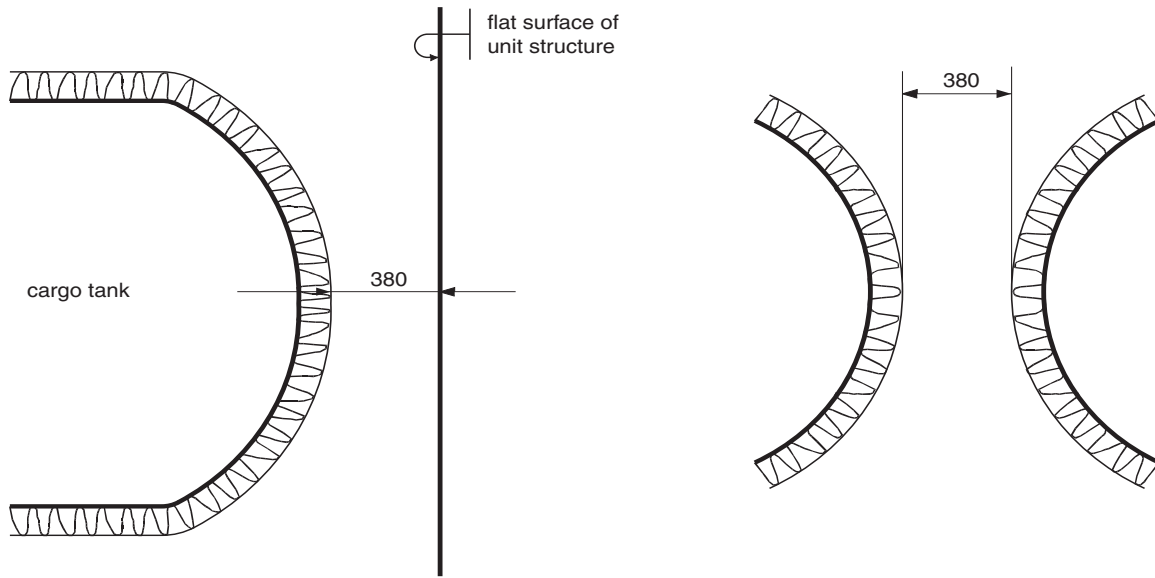

Figure 4 : Minimum passage between flat surfaces

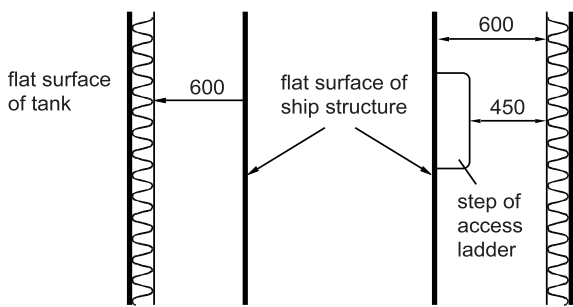

Figure 5 : Minimum distance of cargo tank sump and inner bottom

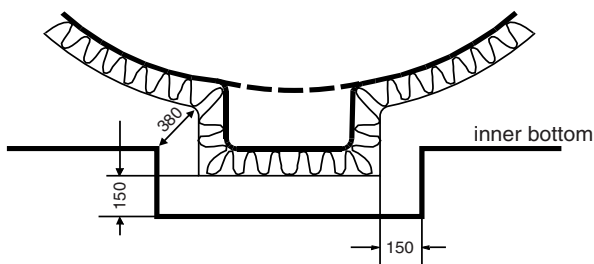
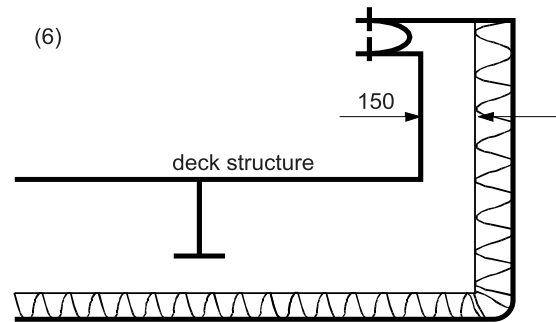

Figure 6 : Minimum distance between cargo dome and deck structures



4.1.3 Passage through hatches and manholes

IGC CODE REFERENCE : Ch 3, 3.5

For the purpose of the requirements in IGC Code 3.5.3, the following applies:

- a) The term "minimum clear opening of not less than 600 x 600 mm" means that such openings may have corner radii up to a maximum of 100 mm (see Fig 7).

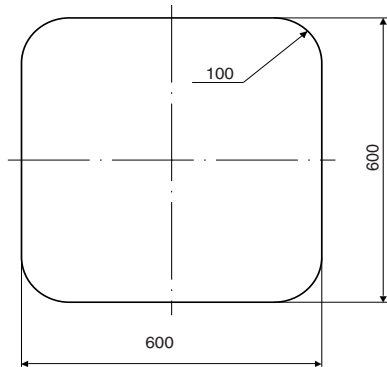
Figure 7 : Minimum horizontal hatch size

- b) The term “minimum clear opening of not less than 600 x 800 mm” also includes an opening of the size specified in Fig 8:

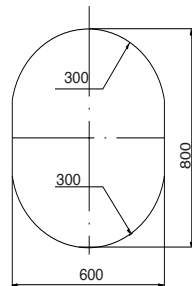
Figure 8 : Minimum size of manholes

- c) Circular access openings in type C cargo tanks are to have diameters of not less than 600 mm.

4.1.4 Cofferdams

IGC CODE REFERENCE : Ch 3, 3.5

Where fitted, cofferdams are to have sufficient size for easy access to all their parts. The width of the cofferdams may not be less than 600 mm.

4.1.5 Pipe tunnels

IGC CODE REFERENCE : Ch 3, 3.5

Pipe tunnels are to have enough space to permit inspection of pipes. The pipes in pipe tunnels are to be installed as high as possible from the unit's bottom.

5 Air-locks

5.1 Arrangement

5.1.1

IGC CODE REFERENCE : Ch 3, 3.6.1

Air-locks are to be such as to provide easy passage and are to cover a deck area of not less than 1,5 m². Air-locks are to be kept unobstructed and may not be employed for other uses, such as storage.

5.2 Alarm

5.2.1 Alarm signalling lamp

IGC CODE REFERENCE : Ch 3, 3.6.3

The alarm systems are to be of the intrinsically safe type. However, signalling lamps may be of a safe type authorised for the dangerous spaces in which they are installed.

5.3 Electrical equipment

5.3.1 Acceptable alternatives to differential pressure

IGC CODE REFERENCE : Ch 3, 3.6.4

The following means are considered acceptable alternatives to differential pressure sensing devices in spaces having a ventilation rate not less than 30 air changes per hour:

- monitoring of current or power in the electrical supply to the ventilation motors; or
- air flow sensors in the ventilation ducts.

In spaces where the ventilation rate is less than 30 air changes per hour and where one of the above alternatives is fitted, in addition to the alarms required in IGC Code 3.6.3, arrangements are to be made to de-energise electrical equipment which is not of the certified safe type if more than one air-lock door is moved from the closed position.

5.4 Ventilation

5.4.1 Air changes

IGC CODE REFERENCE : Ch 3, 3.6.5

The spaces protected by air-locks are to be ventilated for the time necessary to give at least 10 air changes prior to energising the non-safe type electrical installations.

6 Bilge, ballast and fuel oil arrangements

6.1 Drainage arrangement

6.1.1 Drainage of dry spaces in the cargo area

IGC CODE REFERENCE : Ch 3, 3.7

Dry spaces within the cargo area are to be fitted with a bilge or drain arrangement not connected to the machinery space.

Spaces not accessible at all times are to be fitted with sounding arrangements.

Spaces without a permanent ventilation system are to be fitted with a pressure/vacuum relief system or with air pipes.

6.2 Additional requirements relative to the bilge system

6.2.1 Operation of the bilge system in cargo and interbarrier spaces

IGC CODE REFERENCE : Ch 3, 3.7

Bilge arrangements for holds containing cargo tanks and for interbarrier spaces are to be operable from the weather deck.

6.2.2 Means for leakage detection

IGC CODE REFERENCE : Ch 3, 3.7

With reference to the means to ascertain leakages in holds and/or in interbarrier spaces, the following requirements apply:

- the above-mentioned means is to be suitable to ascertain the presence of water:
 - in holds containing type C independent tanks
 - in holds and interbarrier spaces outside the secondary barrier

- the above-mentioned means is to be suitable to ascertain the presence of liquid cargo in the spaces adjacent to cargo tanks which are not type C independent tanks.

Where the aforesaid spaces may be affected by water leakages from the adjacent unit structures, the means is also to be suitable to ascertain the presence of water.

Where the above-mentioned means is constituted by electrical level switches, the relevant circuits are to be

of the intrinsically safe type and signals are to be transduced to the cargo control room.

7 Bow or stern loading and unloading arrangements

7.1 Locations of stopping devices for cargo pumps and compressors

7.1.1

IGC CODE REFERENCE : Ch 3, 3.8.7

As applicable, devices to stop cargo pumps and cargo compressors and to close cargo valves are to be fitted in a position from which it is possible to keep under control the loading/unloading manifolds.

SECTION 4

CARGO CONTAINMENT

Symbols

k : Material factor for steel, defined in Pt B, Ch 4, Sec 1, [2.3] of the Rules for the Classification of Ships

1 Definitions

1.1 Design pressure in harbour conditions

1.1.1

IGC CODE REFERENCE : Ch 4, 4.2.6.4

Where the vapour pressure in harbour conditions is greater than p_0 , defined in IGC 4.2.6.4, this value is to be specified in the operating instructions for the unit's Master.

1.2 Design temperature

1.2.1 Use of cargo heater to raise the cargo temperature

IGC CODE REFERENCE : Ch 4, 4.2.7

Where a cargo heater, intended to raise the cargo temperature to a value permissible for cargo tanks, is envisaged, the following requirements are to be complied with:

- the piping and valves involved are to be suitable for the design loading temperature
- a thermometer is to be fitted at the heater outlet. It is to be set at the design temperature of the tanks and, when activated, it is to give a visual and audible alarm. This alarm is to be installed in the cargo control station or, when such a station is not foreseen, in the wheelhouse.
- The following note is to be written on the Certificate of Fitness: "The minimum permissible temperature in the cargo preheater is..... °C".

2 Design loads

2.1 Internal pressure for integral tanks, membrane tanks and type A independent tanks

2.1.1 General

The inertial internal liquid pressure is to be calculated according to Part B, Chapter 5.

2.2 Internal pressure for type B and C independent tanks

2.2.1 General

IGC CODE REFERENCE : Ch 4, 4.3.2

The inertial internal liquid pressure is to be calculated considering the unit in the following mutually exclusive conditions:

Figure 1 : Dimensionless acceleration in upright unit condition

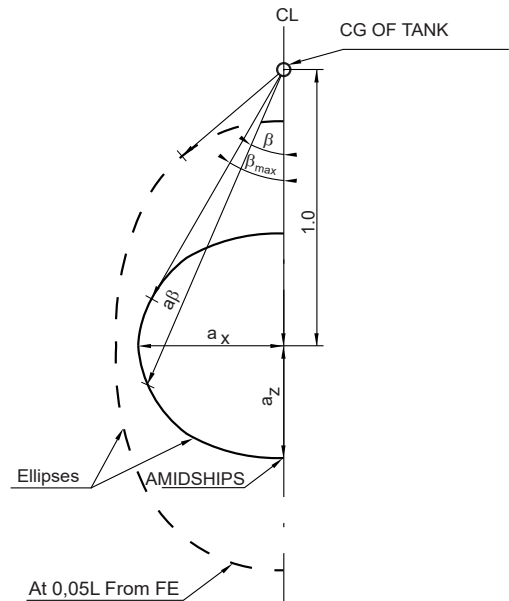

Figure 2 : Dimensionless acceleration in inclined unit condition

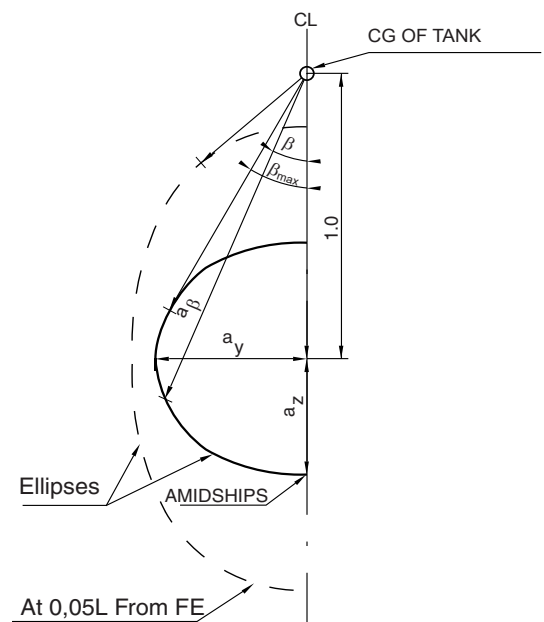
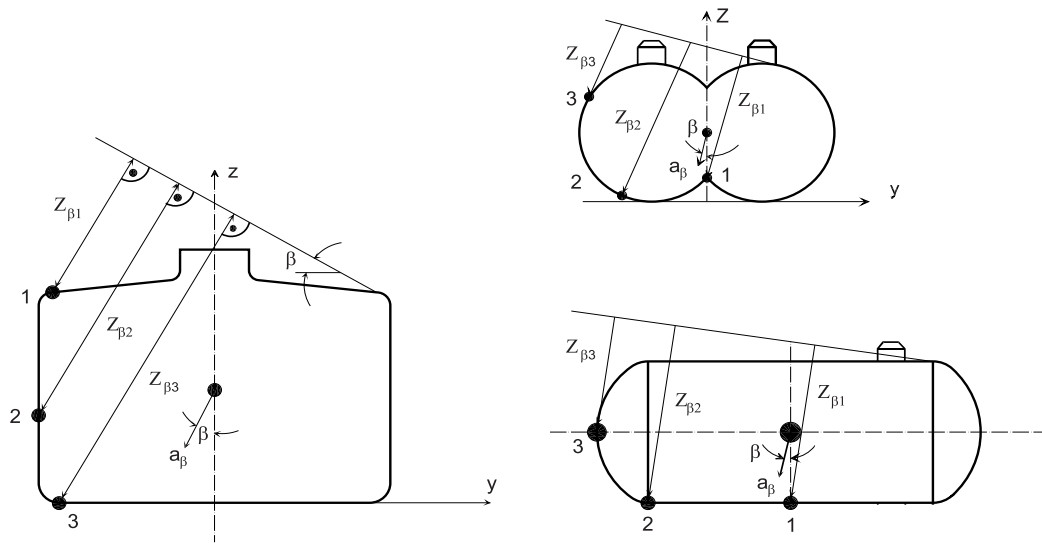

Figure 3 : Determination of liquid height Z_{β} for pressure points 1, 2 and 3



- upright unit conditions (see [2.2.2])
- inclined unit conditions (see [2.2.3]).

2.2.2 Accelerations in upright unit conditions

In these conditions, the unit encounters waves which produce unit motions in the X-Z plane, i.e. surge, heave and pitch.

The dimensionless acceleration a_{β} is to be obtained, for an arbitrary direction β , in accordance with Fig 1, in which the wave transverse and vertical accelerations a_x and a_z , respectively, are calculated from the formula in IGC 4.12

2.2.3 Accelerations in inclined unit conditions

In these conditions, the unit encounters waves which produce unit motions in the X-Y and Y-Z planes, i.e. sway, heave, roll and yaw.

The dimensionless acceleration a_{β} is to be obtained, for an arbitrary direction β , in accordance with Fig 2, in which the wave longitudinal and vertical accelerations a_y and a_z , respectively, are calculated from the formula in IGC 4.12

2.2.4 Liquid heights and pressure

IGC CODE REFERENCE : Ch 4, 4.3.2.2

The liquid heights Z_{β} are to be calculated in accordance with Fig 3 at each calculation point of the tank.

At each calculation point, the maximum internal pressure ($P_{gd,max}$) is to be obtained for the β direction which gives the maximum value of P_{gdr} , according to IGC 4.3.2.2 (see Fig 4).

2.2.5 Cargo mass density

IGC CODE REFERENCE : Ch 4, 4.3.2.2

Where the maximum mass density of the liquid stored is not given, the following values, in t/m^3 , are to be considered:

- $\rho_L = 0,50 t/m^3$ for methane
- $\rho_L = 0,58 t/m^3$ for propane
- $\rho_L = 0,60 t/m^3$ for butane
- $\rho_L = 0,70 t/m^3$ for ammonia (anhydrous).

3 Hull scantlings

3.1 Plating

3.1.1 Minimum net thicknesses

IGC CODE REFERENCE : Ch 4, 4.4

The net thickness of the weather strength deck, trunk deck, tank bulkhead and watertight bulkhead plating within or bounding the longitudinal extension of the cargo area is to be not less than the values given in Tab 1.

3.2 Ordinary stiffeners

3.2.1 Minimum net thicknesses

The net thickness of the web of ordinary stiffeners is to be not less than the value obtained, in mm, from the following formulae:

$$t_{MIN} = 0,8 + 0,013 L k^{1/2} + 4,5 s \quad \text{for } L < 220 \text{ m}$$

$$t_{MIN} = 3 k^{1/2} + 4,5 + s \quad \text{for } L \geq 220 \text{ m}$$

where s is the spacing, in m, of ordinary stiffeners.

Figure 4 : Determination of internal pressure for pressure points 1, 2 and 3

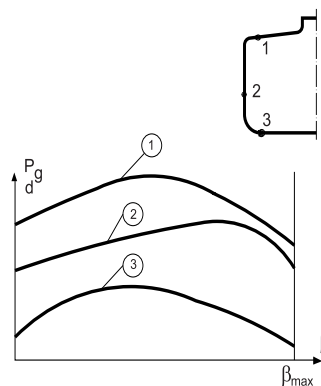

Table 1 : Minimum net thickness of the weather strength deck, trunk deck, tank bulkhead and watertight bulkhead plating

Plating	Minimum net thickness, in mm	
Weather strength deck and trunk deck at midship	Longitudinal framing	$1,6 + 0,032 L k^{1/2} + 4,5 s$ for $L < 220$ $6 k^{1/2} + 5,7 + s$ for $L \geq 220$
	Transverse framing	$1,6 + 0,04 L k^{1/2} + 4,5 s$ for $L < 220$ $6 k^{1/2} + 7,5 + s$ for $L \geq 220$
Weather strength deck and trunk deck at ends and between hatchways	$2,1 + 0,013 L k^{1/2} + 4,5 s$	
Tank bulkhead	$1,7 + 0,013 L k^{1/2} + 4,5 s$	
Watertight bulkhead	$1,3 + 0,013 L k^{1/2} + 4,5 s$	
Note 1: s : Length, in m, of the shorter side of the plate panel.		

3.3 Primary supporting members

3.3.1 Minimum net thicknesses

The net thickness of plating which forms the webs of primary supporting members is to be not less than the value obtained, in mm, from the following formula:

$$t_{\text{MIN}} = 4,1 + 0,015 L k^{1/2}$$

4 Structural analysis of integral tanks

4.1 Scantlings

4.1.1

IGC CODE REFERENCE : Ch 4, 4.4.1

The net scantlings of plating, ordinary stiffeners and primary supporting members of integral tanks are to be not less than those obtained from Part B, Chapter 7, where the hull girder loads and the internal pressure are to be calculated according to Part B, Chapter 5.

5 Structural analysis of membrane tanks

5.1 General

5.1.1 Specific allowable hull girder stresses and/or deflections, indicated by the Designer, are to be taken into account for the determination of the scantlings.

5.2 Scantlings

5.2.1

IGC CODE REFERENCE : Ch 4, 4.4.2

The net scantlings of plating, ordinary stiffeners and primary supporting members of membrane tanks are to be not less than those obtained from Part B, Chapter 7, where the hull girder loads and the internal pressure are to be calculated according to Part B, Chapter 5.

6 Structural analysis of type A independent tanks

6.1 Scantlings

6.1.1

IGC CODE REFERENCE : Ch 4, 4.4.4

The net scantlings of plating, ordinary stiffeners and primary supporting members of type A independent tanks are to be not less than those obtained from Part B, Chapter 7, where the hull girder loads and the internal pressure are to be calculated according to Part B, Chapter 5.

When calculating the internal pressure, the presence of the dome may be disregarded.

7 Structural analysis of type B independent tanks

7.1 Plating and ordinary stiffeners

7.1.1 Strength check of plating and ordinary stiffeners subject to lateral pressure

IGC CODE REFERENCE : Ch 4, 4.5

The net scantlings of plating and ordinary stiffeners of type B independent tanks are to be not less than those obtained from the applicable formulae in Part B, Chapter 7, where the internal pressure is to be calculated according to [2.2].

7.1.2 Buckling check

IGC CODE REFERENCE : Ch 4, 4.5

The scantlings of plating and ordinary stiffeners of type B independent tanks are to be not less than those obtained from the applicable formulae in Part B, Chapter 7.

7.2 Primary supporting members

7.2.1 Analysis criteria

IGC CODE REFERENCE : Ch 4, 4.5

The analysis of the primary supporting members of the tank subjected to lateral pressure based on a three dimensional

model is to be carried out according to the following requirements:

- the structural modelling is to comply with the requirements from Pt B, Ch 7, App 1, [1] to Pt B, Ch 7, App 1, [3] of the Rules for the Classification of Ships
- the stress calculation is to comply with the requirements in Pt B, Ch 7, App 1, [5] of the Rules for the Classification of Ships
- the model extension is to comply with [7.2.2]
- the wave hull girder loads and the wave pressures to be applied on the model are to comply with [7.2.3]
- the inertial loads to be applied on the model are to comply with [7.2.4].

7.2.2 Model extension

The longitudinal extension of the structural model is to comply with Pt B, Ch 7, App 1, [3.2] of the Rules for the Classification of Ships. In any case, the structural model is to include the hull and the tank with its supporting and keying system.

7.2.3 Wave hull girder loads and wave pressures

IGC CODE REFERENCE : Ch 4, 4.5

Wave hull girder loads and wave pressures are to be obtained from a complete analysis of the unit motion and accelerations in irregular waves, to be submitted to the Society for approval, unless these data are available from similar units.

These loads are to be obtained as the most probable the unit may experience during its operating life, for a probability level of 10⁻⁸.

7.2.4 Inertial loads

IGC CODE REFERENCE : Ch 4, 4.5

The inertial loads are to be obtained from the formulae in IGC 4.3.2.

7.2.5 Yielding check of primary supporting members of type B independent tanks primarily constructed of bodies of revolution

IGC CODE REFERENCE : Ch 4, 4.5

The equivalent stresses of primary supporting members are to comply with the following formula:

$$\sigma_E \leq \sigma_{ALL}$$

where:

- σ_E : Equivalent stress, in N/mm², to be obtained from the formula in IGC 4.5.1.8 for each of the following stress categories, defined in IGC 4.13:
- primary general membrane stress
 - primary local membrane stress
 - primary bending stress
 - secondary stress

σ_{ALL} : allowable stress, defined in IGC 4.5.1.4 for each of the stress categories above.

7.2.6 Yielding check of primary supporting members of type B independent tanks primarily constructed of plane surfaces

IGC CODE REFERENCE : Ch 4, 4.5

The equivalent stresses of primary supporting members are to comply with the following formula:

$$\sigma_E \leq \sigma_{ALL}$$

where:

σ_E : Equivalent stress, in N/mm², to be obtained from the formulae in Pt B, Ch 7, App 1, [5.1] of the Rules for the Classification of Ships, as a result of direct calculations to be carried out in accordance with [7.2.1]

σ_{ALL} : Allowable stress, in N/mm², to be obtained from Tab 2.

Table 2 : Allowable stress for primary supporting members primarily constructed of plane surfaces

Material	Allowable stress, in N/mm ²
C-Mn steel and Ni-steels	The lesser of: <ul style="list-style-type: none"> • 0,75 R_{eH} • 0,5 R_m
Austenitic steels	The lesser of: <ul style="list-style-type: none"> • 0,80 R_{eH} • 0,4 R_m
Aluminium alloy	The lesser of: <ul style="list-style-type: none"> • 0,75 R_{eH} • 0,35 R_m

Note 1:

R_{eH} : Minimum yield stress, in N/mm², of the material, as defined in Pt B, Ch 4, Sec 1, [2.1] of the Rules for the Classification of Ships

R_m : Ultimate minimum tensile strength, in N/mm², of the material, as defined in Pt B, Ch 4, Sec 1, [2.1] of the Rules for the Classification of Ships.

7.2.7 Buckling check of local buckling of plate panels of primary supporting members

IGC CODE REFERENCE : Ch 4, 4.5

A local buckling check is to be carried out according to Pt B, Ch 7, Sec 1, [5] of the Rules for the Classification of Ships for plate panels which constitute primary supporting members.

In performing this check, the stresses in the plate panels are to be obtained from direct calculations to be carried out in accordance with [7.2.1].

7.3 Fatigue analysis

7.3.1 General

IGC CODE REFERENCE : Ch 4, 4.4.5.6

The fatigue analysis is to be performed for areas where high wave induced stresses or large stress concentrations are expected, for welded joints and parent material. Such areas are to be defined by the Designer and agreed by the Society on a case-by-case basis.

7.3.2 Material properties

IGC CODE REFERENCE : Ch 4, 4.4.5.6

The material properties affecting fatigue of the items checked are to be documented. Where this documentation is not available, the Society may request to obtain these properties from experiments performed in accordance with recognised standards.

7.3.3 Wave loads

In upright unit and in inclined unit conditions the wave loads to be considered for the fatigue analysis of the tank include:

- maximum and minimum wave hull girder loads and wave pressures, to be obtained from a complete analysis of the unit motion and accelerations in irregular waves, to be submitted to the Society for approval, unless these data are available from similar units. These loads are to be obtained as the most probable the unit may experience during its operating life, for a probability level of 10^{-8} .
- Maximum and minimum inertial pressures, to be obtained from the formulae in IGC 4.3.2 as a function of the arbitrary direction β .

7.3.4 Simplified stress distribution for fatigue analysis

IGC CODE REFERENCE : Ch 4, 4.3.4.3

The simplified long-term distribution of wave loads indicated in IGC Code 4.3.4.3 may be represented by means of 8 stress ranges, each characterised by an alternating stress $\pm\sigma_i$ and a number of cycles n_i (see Fig 5). The corresponding values of σ_i and n_i are to be obtained from the following formulae:

$$\sigma_i = \sigma_0 \left(1,0625 - \frac{i}{8} \right)$$

$$n_i = 0,9 \cdot 10^i$$

where:

- σ_i : Stress ($i = 1, 2, \dots, 8$), in N/mm² (see Fig 5)
- σ_0 : Most probable maximum stress over the life of the unit, in N/mm², for a probability level of 10^{-8}
- n_i : Number of cycles for each stress σ_i , considered ($i = 1, 2, \dots, 8$).

7.3.5 Conventional cumulative damage

IGC CODE REFERENCE : Ch 4, 4.4.5.6

For each structural detail for which the fatigue analysis is to be carried out, the conventional cumulative damage is to be calculated according to the following procedure:

- the long-term value of hot spot stress range $\Delta\sigma_{S,0}$ is to be obtained from the following formula:

$$\Delta\sigma_{S,0} = |\sigma_{S,MAX} - \sigma_{S,MIN}|$$

where:

$\sigma_{S,MAX}, \sigma_{S,MIN}$: Maximum and minimum hot spot stress to be obtained from a structural analysis carried out in accordance with Pt B, Ch 7, App 1 of the Rules for the Classification of Ships, where the wave loads are those defined in [7.3.3]

- the long-term value of the notch stress range $\Delta\sigma_{N,0}$ is obtained from the formulae in Pt B, Ch 7, Sec 2, [3.3] as a function of the hot spot stress range $\Delta\sigma_{S,0}$
- the long-term distribution of notch stress ranges $\Delta\sigma_{N,i}$ is to be calculated. Each stress range $\Delta\sigma_{N,i}$ of the distribution, corresponding to n_i stress cycles, is obtained from the formulae in [7.3.4], where σ_0 is taken equal to $\Delta\sigma_{N,0}$.
- For each notch stress range $\Delta\sigma_{N,i}$, the number of stress cycles N_i which cause the fatigue failure is to be obtained by means of S-N curves corresponding to the as-rolled condition (see Fig 6). The criteria adopted for obtaining the S-N curves are to be documented. Where this documentation is not available, the Society may require the curves to be obtained from experiments performed in accordance with recognised standards.
- The conventional cumulative damage for the i notch stress ranges $\Delta\sigma_{N,i}$ is to be obtained from the formula in IGC 4.4.5.6.

Figure 5 : Simplified stress distribution for fatigue analysis

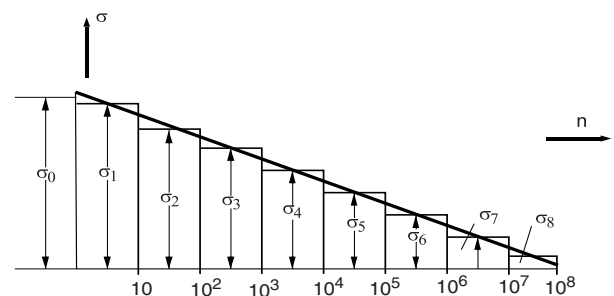
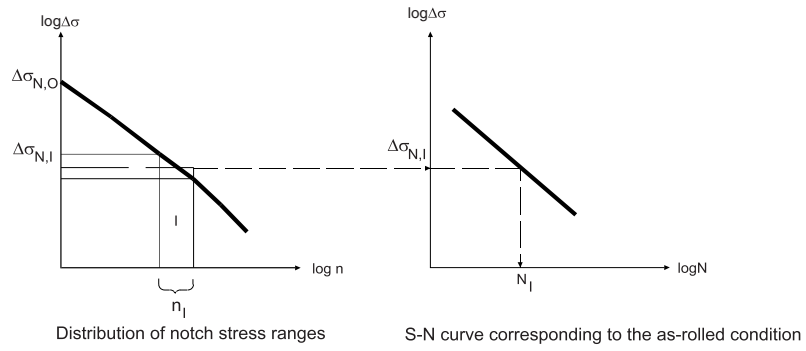

Figure 6 : Fatigue check based on conventional cumulative damage method



7.3.6 Check criteria

The conventional cumulative damage, to be calculated according to [7.3.5], is to be not greater than C_{Wv} , defined in IGC 4.4.5.6.

7.4 Crack propagation analysis

7.4.1 General

IGC CODE REFERENCE : Ch 4, 4.4.5

The crack propagation analysis is to be carried out for highly stressed areas. The latter are to be defined by the Designer and agreed by the Society on a case-by-case basis. Propagation rates in the parent material, weld metal and heat-affected zone are to be considered.

The following checks are to be carried out:

- crack propagation from an initial defect, in order to check that the defect will not grow and cause a brittle fracture before the defect is detected; this check is to be carried out according to [7.4.4]
- crack propagation from an initial through thickness defect, in order to check that the defect, resulting in a leakage, will not grow and cause a brittle fracture less than 15 days after its detection; this check is to be carried out according to [7.4.5].

7.4.2 Material properties

IGC CODE REFERENCE : Ch 4, 4.4.5

The material fracture mechanical properties used for the crack propagation analysis, i.e. the properties relating the crack propagation rate to the stress intensity range at the crack tip, are to be documented for the various thicknesses of parent material and weld metal alike. Where this documentation is not available, the Society may request to obtain these properties from experiments performed in accordance with recognised standards.

7.4.3 Simplified stress distribution for crack propagation analysis

IGC CODE REFERENCE : Ch 4, 4.3.4.4

The simplified wave load distribution indicated in IGC Code 4.3.4.4 may be represented over a period of 15 days by means of 5 stress ranges, each characterised by an alternating stress $\pm\sigma_i$ and number of cycles, n_i (see Fig 7). The corresponding values of σ_i and n_i are to be obtained from the following formulae:

$$\sigma_i = \sigma_0 \left(1,1 - \frac{i}{5,3} \right)$$

$$n_i = 0,913 \cdot 10^i$$

where:

σ_i : Stress ($i = 1,06; 2,12; 3,18; 4,24; 5,30$), in N/mm², (see Fig 7)

σ_0 : Defined in [7.3.4]

n_i : Number of cycles for each stress σ_i considered ($i = 1,06; 2,12; 3,18; 4,24; 5,30$).

Figure 7 : Simplified stress distribution for crack propagation analysis

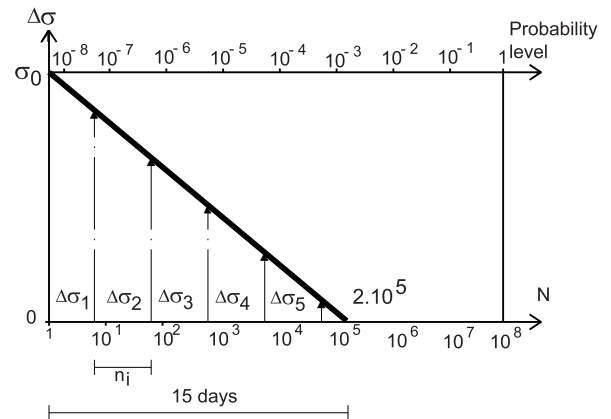

7.4.4 Crack propagation analysis from an initial defect

IGC CODE REFERENCE : Ch 4, 4.4.5

It is to be checked that an initial crack will not grow, under wave loading based on the stress distribution in [7.3.4], beyond the allowable crack size.

The initial size and shape of the crack is to be considered by the Society on a case-by-case basis, taking into account the structural detail and the inspection method.

The allowable crack size is to be considered by the Society on a case-by-case basis; in any event, it is to be taken less than that which may lead to a loss of effectiveness of the structural element considered.

7.4.5 Crack propagation analysis from an initial through thickness defect

IGC CODE REFERENCE : Ch 4, 4.4.5

It is to be checked that an initial through thickness crack will not grow, under dynamic loading based on the stress distribution in [7.4.3], beyond the allowable crack size.

The initial size of the through thickness crack is to be taken not less than that through which the minimum flow size that can be detected by the monitoring system (e.g. gas detectors) may pass.

The allowable crack size is to be considered by the Society on a case-by-case basis; in any event, it is to be taken far less than the critical crack length, defined in [7.4.6].

7.4.6 Critical crack length

IGC CODE REFERENCE : Ch 4, 4.4.5

The critical crack length is the crack length from which a brittle fracture may initiate and it is to be considered by the Society on a case-by-case basis. In any event, it is to be evaluated for the most probable maximum stress experienced by the structural element in the unit life, which is equal to the stress in the considered detail obtained from the structural analysis to be performed in accordance with [7.2.1].

8 Structural analysis of type C independent tanks

8.1 Stiffening rings in way of tank supports

8.1.1 Structural model

IGC CODE REFERENCE : Ch 4, 4.4.6

The stiffening rings in way of supports of horizontal cylindrical tanks are to be modelled as circumferential beams constituted by web, flange, doubler plate, if any, and plating attached to the stiffening rings.

8.1.2 Width of attached plating

IGC CODE REFERENCE : Ch 4, 4.4.6

On each side of the web, the width of the attached plating to be considered for the yielding and buckling checks of the stiffening rings, as in [8.1.5] and [8.1.6], respectively, is to be obtained, in mm, from the following formulae:

- $b = 0,78 \cdot \sqrt{rt}$ for cylindrical shell,
- $b = 20 t_b$ for longitudinal bulkheads (in the case of lobe tanks)

where:

r : Mean radius, in mm, of the cylindrical shell

t : Shell thickness, in mm

t_b : Bulkhead thickness, in mm.

A doubler plate, if any, may be considered as belonging to the attached plating.

8.1.3 Boundary conditions

IGC CODE REFERENCE : Ch 4, 4.4.6

The boundary conditions of the stiffening ring are to be modelled as follows:

- circumferential forces applied on each side of the ring, whose resultant is equal to the shear force in the tank and calculated through the bi-dimensional shear flow theory
- reaction forces in way of tank supports, to be obtained according to [9.2].

8.1.4 Lateral pressure

IGC CODE REFERENCE : Ch 4, 4.4.6

The lateral pressure to be considered for the check of the stiffening rings is to be obtained from [2.2].

8.1.5 Yielding check

IGC CODE REFERENCE : Ch 4, 4.4.6

The equivalent stress in stiffening rings in way of supports is to comply with the following formula:

$$\sigma_E \leq \sigma_{ALL}$$

where:

σ_E : Equivalent stress in stiffening rings calculated for the load cases defined in IGC 4.6.2 and IGC 4.6.3, in N/mm², and to be obtained from the following formula:

$$\sigma_E = \sqrt{(\sigma_N + \sigma_B) + 3\tau^2}$$

σ_N : Normal stress, in N/mm², in the circumferential direction of the stiffening ring

σ_B : Bending stress, in N/mm², in the circumferential direction of the stiffening ring

τ : Shear stress, in N/mm², in the stiffening ring

σ_{ALL} : Allowable stress, in N/mm², to be taken equal to the lesser of the following values:

- $0,57 R_m$
- $0,85 R_{eH}$

R_m : Defined in Pt B, Ch 4, Sec 1, [2.1] of the Rules for the Classification of Ships

R_{eH} : Defined in Pt B, Ch 4, Sec 1, [2.1] of the Rules for the Classification of Ships.

8.1.6 Buckling check

IGC CODE REFERENCE : Ch 4, 4.4.6

The buckling strength of the stiffening rings is to be checked in compliance with the applicable formulae in Pt B, Ch 7, Sec 2 of the Rules for the Classification of Ships.

9 Supports

9.1 Structural arrangement

9.1.1 General

REFERENCE IGC CODE : Ch 4, 6

The reaction forces in way of tank supports are to be transmitted as directly as possible to the hull primary supporting members, minimising stress concentrations.

Where the reaction forces are not in the plane of primary members, web plates and brackets are to be provided in order to transmit these loads by means of shear stresses.

9.1.2 Structure continuity

Special attention is to be paid to continuity of structure between circular tank supports and the primary supporting members of the unit.

9.1.3 Openings

IGC CODE REFERENCE : Ch 4, 4.6

In primary supporting members of tank supports and hull structures in way of tank supports which constitute hull supports, openings are to be avoided and local strengthening may be necessary.

9.1.4 Antiflotation arrangements

IGC CODE REFERENCE : Ch 4, 4.6.7

Adequate clearance between the tanks and the hull structures is to be provided in all operating conditions.

9.2 Calculation of reaction forces in way of tank supports

9.2.1

IGC CODE REFERENCE : Ch 4, 4.6

The reaction forces in way of tank supports are to be obtained from the structural analysis of the tank or stiffening

rings in way of tank supports, considering the loads specified in:

- [6], for the structural analysis of type A independent tanks
- [7], for the structural analysis of type B independent tanks
- [8], for the structural analysis of type C independent tanks.

The final distribution of the reaction forces at the supports is not to show any tensile forces.

9.3 Keys

9.3.1 General

Fillings lower than 90% are generally not admitted for tanks having no upper rolling keys.

The structure of the tank and of the unit is to be reinforced in way of the keys so as to support the reactions and the corresponding moments.

9.3.2 Rolling keys

Rolling keys are to be checked under transverse and vertical accelerations, defined in Pt B, Ch 5, Sec 3, [3.4.1] for the inclined unit conditions, and applied on the maximum weight of the full tank.

It is to be checked that the combined stress in rolling keys is in compliance with the following formula:

$$\sigma_{ALL} > \sigma_C$$

where:

σ_{ALL} : Allowable stress, N/mm², to be taken equal to the minimum of 0,75 R_{eH} and 0,5 R_m

R_{eH} : Yield stress, in N/mm², of the steel used, at 20°C

R_m : Minimum ultimate tensile strength, in N/mm², at 20°C.

9.3.3 Pitching keys

Pitching keys are to be checked under longitudinal accelerations, to be taken not less than 0,3, and vertical accelerations, defined in Pt B, Ch 5, Sec 3, [3.4.1] for the upright conditions, and applied on the maximum weight of the full tank.

It is to be checked that the combined stress in pitching keys is in compliance with the following formula:

$$\sigma_{ALL} > \sigma_C$$

where:

σ_{ALL} : Allowable stress, N/mm², defined in [9.3.2].

9.4 Scantlings of type C independent tank supports and hull structures in way

9.4.1

IGC CODE REFERENCE : Ch 4, 4.6

The net scantlings of plating, ordinary stiffeners and primary supporting members of tank supports and hull structures in way are to be not less than those obtained by applying the criteria in Part B, Chapter 7.

The hull girder loads and the lateral pressure to be considered in the formulae above are to be obtained from the formulae in Part B, Chapter 5.

The values of reaction forces in way of tank supports to be considered for the scantlings of these structural elements are to be obtained from a structural analysis of the tank (see [9.2]) in which the unit accelerations defined in [2.2] are multiplied by 0,625.

10 Secondary barrier

10.1 Secondary barrier extent

10.1.1

IGC CODE REFERENCE : Ch 4, 4.7

The extent of the secondary barrier is to be not less than that necessary to protect the hull structures assuming that the cargo tank is breached at a static angle of heel of 30°, with an equalisation of the liquid cargo in the tank (see Fig 8).

Figure 8 : Secondary barrier extension

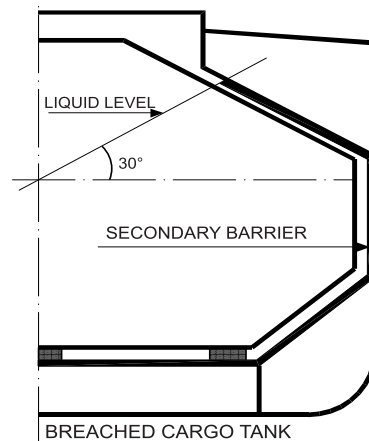

11 Insulation

11.1 Heating of structures

11.1.1 Segregation of heating plant

IGC CODE REFERENCE : Ch 4, 4.8.4

Where a hull heating system complying with IGC 4.8.4 is installed, this system is to be contained solely within the cargo area or the drain returns from the hull heating coils in the wing tanks, cofferdams and double bottom are to be led to a degassing tank. The degassing tank is to be located in the cargo area and the vent outlets are to be located in a safe position and fitted with a flame screen.

11.1.2 Temperature of steam and heating media within the cargo area

IGC CODE REFERENCE : Ch 4, 4.8.4

The maximum temperature of steam and heating media within the cargo area is to be adjusted to take into account the temperature class of the cargoes.

12 Materials

12.1 Insulation material characteristics

12.1.1

IGC CODE REFERENCE : Ch 4, 4.9.5 AND 4.9.6

The materials for insulation are to be approved by the Society.

The approval of bonding materials, sealing materials, lining constituting a vapour barrier or mechanical protection is to be considered by the Society on a case-by-case basis. In any event, these materials are to be chemically compatible with the insulation material.

12.1.2

IGC CODE REFERENCE : Ch 4, 4.9.5 AND 4.9.6

Before applying the insulation, the surfaces of the tank structures or of the hull are to be carefully cleaned.

12.1.3

IGC CODE REFERENCE : Ch 4, 4.9.5 AND 4.9.6

Where applicable, the insulation system is to be suitable to be visually examined at least on one side.

12.1.4

IGC CODE REFERENCE : Ch 4, 4.9.5 AND 4.9.6

When the insulation is sprayed or foamed, the minimum steel temperature at the time of application is to be not less than the temperature given in the specification of the insulation.

13 Construction and testing

13.1 Integral tank testing

13.1.1

IGC CODE REFERENCE : Ch 4, 4.10.6

The testing of integral tanks is to comply with the requirements in Pt B, Ch 12, Sec 3 of the Rules for the Classification of Ships.

13.2 Membrane and semi-membrane tanks testing

13.2.1

IGC CODE REFERENCE : Ch 4, 4.10.7

The testing of membrane and semi-membrane tanks is to comply with the requirements in Pt B, Ch 12, Sec 3 of the Rules for the Classification of Ships.

13.3 Independent tank testing

13.3.1

IGC CODE REFERENCE : Ch 4, 4.10.10

The conditions in which testing is performed are to simulate as far as possible the actual loading on the tank and its supports.

13.3.2

IGC CODE REFERENCE : Ch 4, 4.10.10

When testing takes place after installation of the cargo tank, provision is to be made prior to the launching of the unit in order to avoid excessive stresses in the unit structures.

13.4 Final tests

13.4.1

IGC CODE REFERENCE : Ch 4, 4.10

The tests on the completed system are to be performed in the presence of a Surveyor and are to demonstrate that the cargo containment arrangements are capable of being inerted, cooled, loaded and unloaded in a satisfactory way and that all the safety devices operate correctly.

13.4.2

IGC CODE REFERENCE : Ch 4, 4.10

Tests are to be performed at the minimum service temperature or at a temperature very close to it.

13.4.3

IGC CODE REFERENCE : Ch 4, 4.10

The regasification, reliquefaction and inert gas production systems, if any, and the installation, if any, for use of gas as fuel for boilers and internal combustion engines are also to be tested to the satisfaction of the Surveyor.

13.4.4

IGC CODE REFERENCE : Ch 4, 4.10

All operating data and temperatures read during the first cargo operations are to be sent to the Society.

13.4.5

IGC CODE REFERENCE : Ch 4, 4.10

All data and temperatures read during subsequent cargo operations are to be kept at the disposal of the Society for a suitable period of time.

14 Structural details

14.1 Special structural details

14.1.1 The specific requirements in Pt B, Ch 13, Sec 2, [2.4] for units with the service notation **FSRU** are to be complied with.

14.2 Connections of the inner hull plating with intermediate plating

14.2.1

IGC CODE REFERENCE : Ch 4, 4.10

The connections of the inner hull plating with intermediate plating are to be made according to:

- sheets 4.5 to 4.7 in Pt B, Ch 12, App 1 of the Rules for the Classification of Ships for position 1 in Fig 9
- sheets 6.8 and 6.9 in Pt B, Ch 12, App 1 of the Rules for the Classification of Ships for position 2 in Fig 9
- for positions 3 and 4 in Fig 9, in a similar way to positions 1 and 2.

Figure 9 : Positions of connections

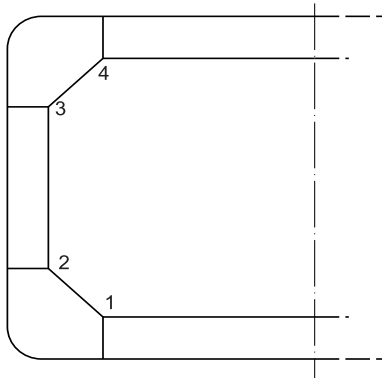

14.2.2 Where there is no prolonging bracket in way of knuckle joints in positions 1 and/or 2, the connection of transverse webs to the inner hull and longitudinal girder plating is to be made with partial penetration welds over a length not less than 400 mm.

14.3 Connections of inner bottom with transverse cofferdam bulkheads

14.3.1 General

In addition to sheet 3.5 in Pt B, Ch 12, App 1 of the Rules for the Classification of Ships, the requirements in [14.3.2] to [14.3.4] apply.

14.3.2 Floors

IGC CODE REFERENCE : Ch 4, 4.10

The thickness and material properties of the supporting floors are to be at least equal to those of the cofferdam bulkhead plating.

14.3.3 Vertical webs within cofferdam bulkhead

IGC CODE REFERENCE : Ch 4, 4.10

Vertical webs fitted within the cofferdam bulkhead are to be aligned with the double bottom girders.

14.3.4 Manholes

IGC CODE REFERENCE : Ch 4, 4.10

Manholes in double bottom floors aligned with the cofferdam bulkhead plating are to be located as low as practicable and at mid-distance between two adjacent longitudinal girders.

14.4 Cut-outs and connections

14.4.1 Cut-outs

IGC CODE REFERENCE : Ch 4, 4.10

Cut-outs for the passage of inner hull and cofferdam bulkhead ordinary stiffeners through the vertical webs are to be closed by collar plates welded to the inner hull plating.

14.4.2 Connection of the cargo containment system to the hull structure

IGC CODE REFERENCE : Ch 4, 4.10

Where deemed necessary, adequate reinforcements are to be fitted in the double hull and transverse cofferdams at connection of the cargo containment system to the hull structure. Details of the connection are to be submitted to the Society for approval.

SECTION 5

REGASIFICATION SYSTEMS, PROCESS PRESSURE VESSELS AND LIQUID, VAPOUR AND PRESSURE PIPING SYSTEMS

1 Regasification systems

1.1 General

1.1.1 These are systems where the cargo is regasified from a liquid to a vapour and then sent ashore via a pipeline for use as a gaseous fuel. The vapour may or may not be treated on board the installation dependent on the requirements of the end user.

The vaporisers are to be selected to satisfy the heaviest demand of the end user and should be able to function during all motions of the installation.

Selection of the vaporisers has to consider environmental impact in terms of air emissions, use of biocides or changes in seawater temperature.

The availability of auxiliary systems serving the process system and on which the process system may depend has also to be considered in selection of design code and specification of such systems.

The design has to ensure that cross contamination of auxiliary systems with hydrocarbons will be adequately protected against.

1.2 Design and construction

1.2.1 The design and construction of regasification systems are to be in accordance with a recognized Standard and with the requirement of this section. The standards are to be adhered to in their entirety.

Use of other standards is subject to the approval by the Society.

2 Process pressure vessels

2.1

2.1.1

IGC CODE REFERENCE : Ch 5, 5.1.2

Process pressure vessels handling cargo are to be considered at least as class 2 pressure vessels, in accordance with Pt C, Ch 1, Sec 3, [1.4.1] of the Rules for the Classification of Ships.

2.1.2 Temperature of steam and heating media within the cargo area

IGC CODE REFERENCE : Ch 5, 5.1

The maximum temperature of steam and heating media within the cargo area is to be adjusted to take into account the temperature class of the cargoes.

3 Cargo and process piping

3.1 General

3.1.1 Cargo import and export system

Provisions for cargo import and export systems are given in Part C, Chapter 5 too.

3.1.2 Provisions for protection of piping against thermal stress

IGC CODE REFERENCE : Ch 5, 5.2.1.2

Expansion joints are to be protected from extensions and compressions greater than the limits fixed for them and the connected piping is to be suitably supported and anchored. Bellow expansion joints are to be protected from mechanical damage.

3.1.3 Segregation of high temperature piping

IGC CODE REFERENCE : Ch 5, 5.2.1.3

High temperature pipes are to be thermally isolated from the adjacent structures. In particular, the temperature of pipelines is not to exceed 220 °C in gas-dangerous zones.

3.1.4 Pressure relief valve setting

IGC CODE REFERENCE : Ch 5, 5.2.1.6

Pressure relief valves are to be set to discharge at a pressure not greater than the design pressure such that the overpressure during discharge does not exceed 110% of the design pressure.

3.1.5 Protection against leakage

IGC CODE REFERENCE : Ch 5, 5.2.1

Where the piping system is intended for liquids having a boiling point lower than - 30 °C, permanent means to avoid possibility of contact between leaks and hull structures are to be provided in all those locations where leakage might be expected, such as shore connections, pump seals, flanges subject to frequent dismantling, etc.

3.1.6 Means for detecting the presence of liquid cargo

IGC CODE REFERENCE : Ch 5, 5.2.1

The means to detect the presence of liquid cargo may be constituted by electrical level switches whose circuit is intrinsically safe. The alarm signals given by the level switches are to be transmitted to the wheelhouse and to the cargo control station, if provided.

3.1.7 Connections of relief valve discharges to cargo tanks

IGC CODE REFERENCE : Ch 5, 5.2.1

The connections, if any, to the cargo tanks of relief valve discharges fitted on the liquid phase cargo piping are not to be fitted with shut-off valves, but are to be provided with non-return valves in the proximity of the tanks.

3.1.8 Centrifugal pumps

IGC CODE REFERENCE : Ch 5, 5.2.1

Overpressure relief valves on cargo pumps may be omitted in the case of centrifugal pumps having a maximum delivery head, the delivery valve being completely closed, not greater than that permitted for the piping.

3.2 Design pressure

3.2.1 Design pressure definition

IGC CODE REFERENCE : Ch 5, 5.2.3.1

For each piping section, the maximum pressure value among those applicable in paragraph 5.2.2.1 of the IGC Code is to be considered.

3.3 Flanges

3.3.1 Flanges not complying with standards

IGC CODE REFERENCE : Ch 5, 5.2.4.5

For flanges not complying with a standard, the dimensions and type of gaskets are to be to the satisfaction of the Society.

3.4 Stress analysis

3.4.1 Calculations in accordance with recognised standards

IGC CODE REFERENCE : Ch 5, 5.2.5

When such an analysis is required, it is to be carried out in accordance with the requirements listed below. Subject to this condition, calculations in accordance with recognised standards are admitted by the Society.

3.4.2 Calculation cases

IGC CODE REFERENCE : Ch 5, 5.2.5

The calculations are to be made for every possible case of operation, but only those leading to the most unfavourable results are required to be submitted.

3.4.3 Loads to be taken for calculation

IGC CODE REFERENCE : Ch 5, 5.2.5

The calculations are to be carried out taking into account the following loads:

- a) piping not subject to green seas:
 - pressure
 - weight of the piping and of the internal fluid
 - contraction
- b) piping subject to green seas that is liable to be in operation at sea and in port:
 - pressure
 - weight of the piping and of the internal fluid
 - green seas
 - contraction
 - unit motion accelerations

- c) piping subject to green seas that is in operation only in port; the more severe of the following two combinations of loads:

- pressure
 - weight of the pipe and of the internal fluid
 - contraction
- and
- weight of the piping
 - green seas
 - expansion, assuming that the thermal stresses are fully relaxed.

3.4.4 Green sea directions

IGC CODE REFERENCE : Ch 5, 5.2.5

When green seas are considered, their effects are to be studied, unless otherwise justified, in the following three directions:

- axis of the unit
- vertical
- horizontal, perpendicular to the axis of the unit.

3.4.5 Stress intensity

IGC CODE REFERENCE : Ch 5, 5.2.5

The stress intensity is to be determined as specified in the formulae in Pt C, Ch 1, Sec 13, [2.3.2] of the Rules for the Classification of Ships for pipes intended for high temperatures:

- a) for primary stresses resulting from:
 - pressure
 - weight
 - green seas
- b) for primary stresses and secondary stresses resulting from contraction.

3.4.6 Stress intensity limits

IGC CODE REFERENCE : Ch 5, 5.2.5

- a) For the first case, the stress intensity is to be limited to the lower of:
 $0,8 R_e$ and $0,4 R_m$
- b) For the second case, the stress intensity is to be limited to the lower of:
 $1,6 R_e$ and $0,8 R_m$.

3.4.7 Piping with expansion devices

IGC CODE REFERENCE : Ch 5, 5.2.5

For piping fitted with expansion devices, their characteristics are to be submitted to the Society. Where these characteristics are such that the forces and moments at the ends of the devices are negligible for the contraction they must absorb, the calculation of the loads due to contraction in the corresponding piping is not required. It is, however, to be checked that the stress intensity corresponding to the primary stresses does not exceed the limits given in [3.4.6].

3.4.8 Flexibility coefficient

IGC CODE REFERENCE : Ch 5, 5.2.5

The flexibility coefficient of elbows is to be determined

from the formulae given in Pt C, Ch 1, Sec 13, [2.3.2] of the Rules for the Classification of Ships for pipes intended for high temperatures.

3.4.9 Local stresses

IGC CODE REFERENCE : Ch 5, 5.2.5

Particular attention is to be paid to the calculation of local stresses in the assemblies subjected to axial forces and bending moments. The Society reserves the right to request additional justifications or local strengthening where considered necessary.

3.5 Aluminised pipes

3.5.1

IGC CODE REFERENCE : Ch 5, 5.2.6

Aluminised pipes may be fitted in ballast tanks, in inerted cargo tanks and, provided the pipes are protected from accidental impact, in hazardous areas on open deck.

4 Cargo system valving requirements

4.1 Cargo tank connections for gauging

4.1.1 Exemption -

IGC CODE REFERENCE : Ch 5, 5.6.2

The requirements in paragraph 5.6.2 of the IGC Code relevant to cargo tank connections for pressure gauges and measuring devices do not apply to tanks with an MARVS not exceeding 0,07 MPa.

4.2 Emergency shutdown

4.2.1 Clarification on location of fusible elements -

IGC CODE REFERENCE : Ch 5, 5.6.4

The cargo stations in way of which the fusible elements mentioned in paragraph 5.6.4 of the IGC Code are to be fitted are to be intended as the loading and unloading manifolds.

The system may be integrated into the fire and gas systems and appropriate level of redundancy based on risk analysis in these locations.

The reliability of the system and risk to process shutdowns may institute the use of different technologies for this system or the use of voting duplicated systems.

4.2.2 Fail-close action of Emergency Shut Down (ESD) valve (1/1/2024)

IGC CODE REFERENCE : Ch 5, 5.6.4

The following requirements specify the arrangements for emergency shut down valve (hereinafter referred to as ESD valve) installed in cargo piping of ships engaged in the carriage of liquefied gases to stop cargo flow in the event of an emergency, either internally within the ship, or during cargo transfer to other ships or shore facilities.

When ESD valve is actuated by hydraulic or pneumatic system, the following are to be complied with:

- a) audible and visible alarm is to be given in the event of loss of pressure that causes activation of fail-close action. The alarm is to be provided in a normally manned control station (e.g. Cargo Control Room and/or the navigation bridge, etc.).
- b) the following conditions are also to be complied to ensure the fail-close action:
 - 1) failure of hydraulic or pneumatic system is not to lead to loss of fail-close functionality (i.e. activated by spring or weight); or
 - 2) hydraulic or pneumatic system for fail-close action is to be arranged with stored power and separated from normal valve operation.

5 Cargo transfer methods

5.1 Discharge into common header

5.1.1

IGC CODE REFERENCE : Ch 5, 5.8

When two or more pumps located in different cargo tanks are operating at the same time discharging into a common header, the stopping of the pumps is to activate an alarm at the centralised cargo control location.

6 Bonding

6.1 Static electricity

6.1.1 Acceptable resistance

IGC CODE REFERENCE : Ch 10, 10.3

To avoid the hazard of an incentive discharge due to the build-up of static electricity resulting from the flow of the liquid/gases/vapours, the resistance between any point on the surface of the cargo and slop tanks, piping systems and equipment, and the hull of the unit is not to be greater than $10^6 \Omega$.

6.1.2 Bonding straps

IGC CODE REFERENCE : Ch 10, 10.3

Bonding straps are required for cargo and slop tanks, piping systems and equipment which are not permanently connected to the hull of the unit, for example:

- a) independent cargo tanks
- b) cargo tank piping systems which are electrically separated from the hull of the unit
- c) pipe connections arranged for the removal of the spool pieces.

Where bonding straps are required, they are to be:

- a) clearly visible so that any shortcoming can be clearly detected
- b) designed and sited so that they are protected against mechanical damage and are not affected by high resistivity contamination, e.g. corrosive products or paint
- c) easy to install and replace.

7 Integrated cargo and ballast system

7.1 General

7.1.1 The requirements for integrated cargo and ballast systems are given in Part C, Chapter 5.

SECTION 6

MATERIALS FOR CONSTRUCTION

1 Material requirements

1.1 Tubes, forgings and castings for cargo and process piping

1.1.1

IGC CODE REFERENCE: Ch 6, Table 6.4

In general, impact tests for forgings, castings and welded and seamless pipes in stainless austenitic grades 304, 304L, 316, 316L, 321 and 347 are required when the design temperature is below -105°C and are to be carried out at -196°C .

1.2 Aluminium coatings

1.2.1

IGC CODE REFERENCE : Ch 6, 6.2

The use of aluminium coatings is prohibited in the cargo tanks, cargo tank deck area, pump rooms, cofferdams or any other area where cargo gas may accumulate.

2 Welding and non-destructive testing

2.1 Welding consumables

2.1.1

IGC CODE REFERENCE : Ch 6, 6.3.2

The content of paragraph 6.3.2 of the IGC Code is also to cover process pressure vessels and secondary barriers.

2.2 Test requirements

2.2.1 Bend tests

IGC CODE REFERENCE : Ch 6, 6.3.4.2

As an alternative to the bend test indicated in paragraph 6.3.4.2 of the IGC Code, a test over a mandrel having a diameter equal to 3 times the thickness with a bend angle up to 120° may be required.

SECTION 7

CARGO PRESSURE/TEMPERATURE CONTROL

1 Cargo Pressure/Temperature Control

1.1 General

1.1.1 The cargo pressure/temperature control has to comply with Chapter 7 of IGC Code and to the following requirements.

2 Additional requirements for refrigerating plants

2.1

2.1.1

IGC CODE REFERENCE : Ch 7, 7.2

In general, in addition to the requirements of 7.2 of the IGC Code, refrigerating plants are to comply with the provisions of Pt C, Ch 1, Sec 4 of the Rules for the Classification of Ships.

3 Reliquefaction plant of FRSU

3.1 Mechanical refrigeration fitted as the primary system for cargo pressure control

3.1.1 General

IGC CODE REFERENCE : Ch 7, 7.2

Paragraph 7.2 of the IGC Code relative to refrigerating systems is based on the assumption that maintenance of the cargo pressure described in 7.1 of the IGC Code is complied with by using means defined in 7.1.1.1 of the Code. That is to say, a mechanical refrigeration system is fitted as the primary means of maintaining the cargo tank pressure below MARVS.

3.1.2 Standby refrigerating units

IGC CODE REFERENCE : Ch 7, 7.2

Paragraph 7.2 of the IGC Code is to apply to refrigeration systems fitted on FSRU, i.e. the standby capacity required is to be as detailed in 7.2.1 of the IGC Code. A standby LNG/refrigerant heat exchanger need not be provided and the fitted LNG/refrigerant heat exchanger is not required to have 25% excess capacity over that for normal requirements. Other heat exchangers utilising water cooling are to have a standby or to have at least 25% excess capacity.

3.1.3 Alternative means for cargo pressure/temperature control

IGC CODE REFERENCE : Ch 7, 7.2

Paragraph 7.2.1 of the IGC Code states that unless an alternative means of controlling the cargo pressure/temperature is provided to the satisfaction of the Administration, a

standby unit (or units) affording spare capacity at least equal to the largest required single unit is (are) to be fitted.

For the purpose of complying with the above, a suitable alternative means of pressure/temperature control would be:

- a) auxiliary boiler(s) capable of burning the boil-off vapours and disposing of the generated steam or an alternative waste heat system acceptable to the Society. Consideration will be given to systems burning only part of the boil-off vapour if it can be shown that MARVS will not be reached within a period of 21 days.
- b) controlled venting of cargo vapours as specified in paragraph 7.1.1.5 of the IGC Code if permitted by the Administration concerned.

3.2 Mechanical refrigeration fitted as a secondary system for cargo pressure control

3.2.1

IGC CODE REFERENCE : Ch 7, 7.2

Where a refrigeration plant is fitted as a means of disposing of excess energy as detailed in the second sentence of 7.1.1.2, no standby unit will be required for the refrigeration plant.

4 Cargo Compressor Systems

4.1 Cargo compressors

4.1.1 All cargo gas compressors are to be located in a dedicated cargo compressor room.

The number of compressors will depend upon the type of cargoes to be carried and are to be of sufficient capacity to handle the volume of boil-off gas generated under normal operating conditions. In general these compressors have to be arranged whereby the failure of one compressor will not affect the capacity of the system to maintain the cargo tank pressure and temperature.

Additionally FSRUs are to have extra, high capacity compressors designed to handle the full quantity of boil off gas generated during loading conditions.

The control of the gas compressors is governed mainly by the cargo tank pressure and protective devices are to be installed on the compressors to prevent the cargo tank pressure being lowered to a value below the design pressure for the relevant tanks.

4.2 Cargo Compressor Drives

4.2.1 Where compressors are driven by a machine which is located outside the compressor room, the following arrangements are to be made:

- a) Drive shafts are to be fitted with flexible couplings or other means suitable to compensate for any misalignment
- b) The shaft bulkhead or deck penetration is to be fitted with a gas-tight gland of a type approved by the Society. The gland is to be efficiently lubricated from outside the compressor room and so designed as to prevent overheating. The seal parts of the gland are to be of material that cannot initiate sparks.
- c) Temperature sensing devices are to be fitted for bulkhead shaft gland.

Where drives are integral with or located in the same space as the compressor then those drives must comply with all regulations for that space.

5 Oxidation Systems

5.1

5.1.1 These are systems whereby boil-off vapours are utilised as shipboard fuel in a boiler to generate steam, in an internal combustion engine as a second/alternative fuel or are disposed of via a thermal oxidiser or a gas combustion unit. In any of the cases gas compressors will be required to direct the boil-off vapours to the particular oxidiser in question, the requirements of these compressors are covered in [4].

SECTION 8

CARGO TANK VENTING SYSTEM

1 Pressure relief systems

1.1 Interbarrier spaces

1.1.1 Protection of interbarrier spaces

IGC CODE REFERENCE : Ch 8, 8.2.2

- The formula for determining the relieving capacity given in paragraph 8.3.2 of the IGC Code is developed for interbarrier spaces surrounding independent type A cargo tanks, where the thermal insulation is fitted to the cargo tanks.
- The relieving capacity of pressure relief devices of interbarrier spaces surrounding independent type B cargo tanks may be determined on the basis of the method given in paragraph 8.2 of the IGC Code; however, the leakage rate is to be determined in accordance with 4.7.6.1 of the IGC Code.
- The relieving capacity of pressure relief devices for interbarrier spaces of membrane and semi-membrane tanks is to be evaluated on the basis of specific membrane/semi-membrane tank design.
- The relieving capacity of pressure relief devices for interbarrier spaces adjacent to integral type cargo tanks may, if applicable, be determined as for type A independent cargo tanks.
- Interbarrier space pressure relief devices in the scope of this interpretation are emergency devices for protecting the hull structure from being unduly overstressed in the event of a pressure rise in the interbarrier space due to primary barrier failure. Therefore such devices need not comply with the requirements of paragraphs 8.2.9 and 8.2.10 of the IGC Code.

1.1.2 Size of pressure relief devices

IGC CODE REFERENCE : Ch 8, 8.2.2

The combined relieving capacity (in m³/s) of the pressure relief devices for interbarrier spaces surrounding type A independent cargo tanks where the insulation is fitted to the cargo tanks may be determined by the following formula:

$$Q_{sa} = 3,4 \cdot A_C \cdot \frac{p}{\rho_v} \cdot \sqrt{h}$$

where:

Q_{sa} : Minimum required discharge rate of air in standard conditions of 273 K and 0,1013 MPa

A_C : Design crack opening area in (m²)

$$A_C = \frac{\pi}{4} \cdot \delta \cdot l$$

with:

δ : Max. crack opening width in (m)

$$\delta = 0,2 \cdot t$$

t : Thickness of tank bottom plating in (m)

l : Design crack length in (m) equal to the diagonal of the largest plate panel of the tank bottom (see Fig 1)

h : Max. liquid height above tank bottom plus 10 × MARVS in (m)

ρ : Density of product liquid phase in t/m³ at the set pressure of the interbarrier space relief device

ρ_v : Density of product vapour phase in t/m³ at the set pressure of the interbarrier space relief device and a temperature of 273 K.

1.2 Vents

1.2.1

IGC CODE REFERENCE : Ch 8, 8.2.9

The height of vent exits as indicated in paragraph 8.2.9 of the IGC Code is also to be measured above storage tanks and cargo liquid lines, where applicable.

1.3 Segregation of vents

1.3.1 Additional requirements on vent location

IGC CODE REFERENCE : Ch 8, 8.2.10

- The distances of the vent exits are to be measured horizontally.
- In the case of carriage of flammable and/or toxic products, the vent exits are to be arranged at a distance of at least 5 m from exhaust ducts and at least 10 m from intake ducts serving cargo pump rooms and/or cargo compressor rooms.
- The distances are also intended to refer to outlets of ventilation ducts of safe spaces.

1.4 Back pressure

1.4.1 Pressure drop in vent lines

IGC CODE REFERENCE : Ch 8, 8.2.16

The pressure drop in the vent line from the tank to the pressure relief valve inlet is not to exceed 3% of the valve set pressure. For unbalanced pressure relief valves the back pressure in the discharge line is not to exceed 10% of the gauge pressure at the relief valve inlet with the vent lines under fire exposure.

Figure 1 : Determination of I

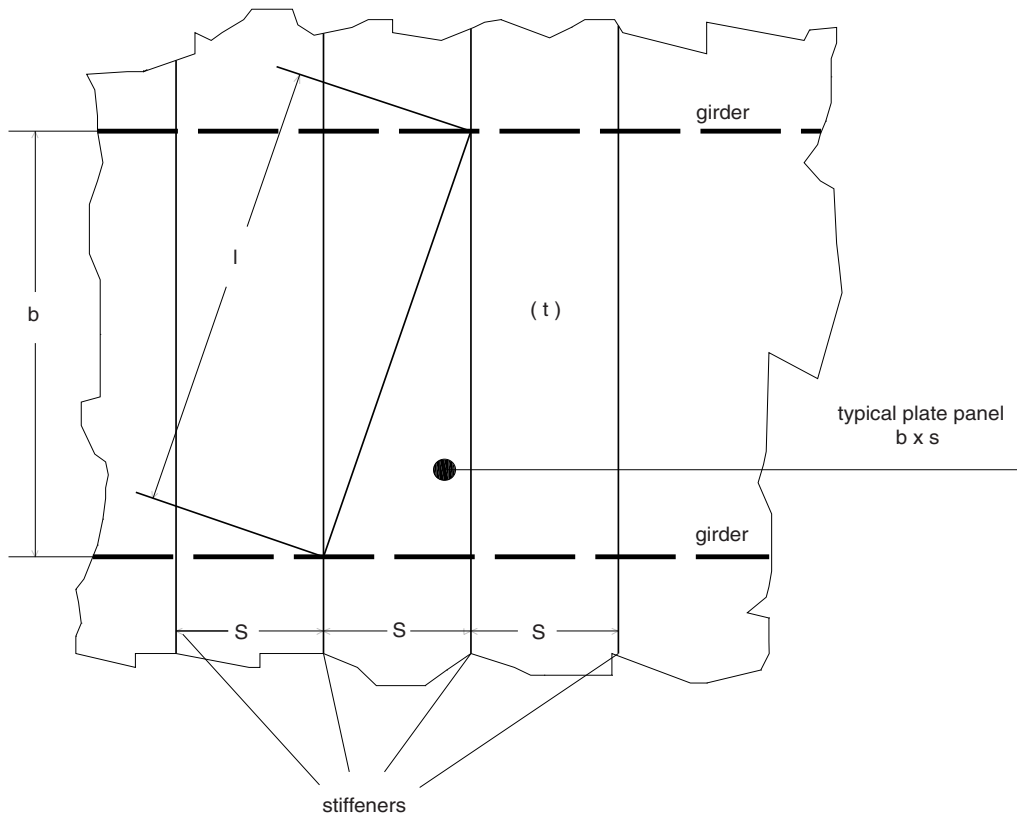

2 Additional pressure relieving system for liquid level control

2.1 General

2.1.1 Additional pressure relieving system

IGC CODE REFERENCE : Ch 8, 8.3.1.2

The override arrangement indicated in paragraph 8.3.1.2 of the IGC Code is to be capable of being manually operated. As an alternative, means for manual venting are to be provided.

2.1.2 Tank filling limits

IGC CODE REFERENCE : Ch 8, 8.3.1

The words 'to prevent the tank from becoming liquid full' in paragraph 8.3.1 of the IGC Code have the following meaning:

At no time during the loading, transport or unloading of the cargo including fire conditions will the tank be more than 98% liquid full, except as permitted by 15.1.3 of the IGC Code. These requirements, together with those of 8.2.17 of the IGC Code, are intended to ensure that the pressure relief valves remain in the vapour phase.

SECTION 9

ENVIRONMENTAL CONTROL

1 Inerting

1.1 General

1.1.1 Dew point

IGC CODE REFERENCE : Ch 9, 9.4.1

As far as the IGC Code requirements relevant to the dew point are concerned, the following additional provisions apply:

- a) where cargo tank insulation is not protected from water vapour penetration by means of an effective vapour barrier, accepted by the Society, the maximum value of the dew point is to be less than the design temperature
- b) where cargo tank insulation is protected by an effective vapour barrier, accepted by the Society, the maximum value of the dew point is to be less than the minimum temperature which may be found on any surface within the spaces filled with dry inert gas or dry air
- c) the temperature of the hull structures adjacent to cargo tanks is not to become lower than the minimum permissible working temperature, specified in Section 6, for the steel grade employed for such hull structures.

1.1.2 Precautions against fire

IGC CODE REFERENCE : Ch 9, 9.4.1

Precautions are to be taken to minimise the risk that static electricity generated by the inert gas system may become a source of ignition.

2 Inert gas production on board

2.1 Exemptions

2.1.1

IGC CODE REFERENCE : Ch 9, 9.5

- a) Inert gas generating systems are to be considered as essential services and are to comply with the applicable Sections of the Rules, as far as applicable.
- b) Where, in addition to inert gas produced on board, it is possible to introduce dry air into the above-mentioned spaces, where this is acceptable depending on the type of cargo tank adopted, or to introduce inert gas from a supply existing on board, it is not necessary that standby or spare components for the inert gas system are kept on board.

SECTION 10

ELECTRICAL INSTALLATIONS

1 General

1.1 Application

1.1.1 The requirements in this Section apply to **FSRUs** units in addition to those contained in Part C, Chapter 2.

1.2 Definitions

1.2.1 Source of release: point or location from which a flammable gas, vapour, or liquid may be released into the atmosphere in such a way that an explosive gas atmosphere could be formed.

1.2.2 (1/1/2021)

Grades of release: the likelihood of the presence of an explosive gas atmosphere, and hence the type of zone, depends mainly on the following grade of release:

- a) continuous grade;
- b) primary grade;
- c) secondary grade.

A continuous grade of release normally leads to a zone 0, a primary grade to zone 1 and a secondary grade to zone 2 (see Note 1).

Note 1: The availability and degree of ventilation do influence the extent of the zone and might even lead to a higher or lower risk zone.

1.2.3 Continuous grade of release: release which is continuous or is expected to occur frequently or for long periods.

1.2.4 Primary grade of release: release which can be expected to occur periodically or occasionally during normal operation.

1.2.5 Secondary grade of release: release which is not expected to occur in normal operation and, if it does occur, is likely to do so only infrequently and for short periods.

1.2.6 Release rate: quantity of flammable gas or vapour emitted per unit time from the source of release.

1.3 Monitoring of circuit in hazardous areas

1.3.1 (1/1/2021)

The device intended to continuously monitor the insulation level of all distribution system is also to monitor all circuits, other than intrinsically safe circuits, connected to apparatus in hazardous areas or passing through such areas.

An audible and visual alarm is to be given, at a manned position, in the event of an abnormally low level of insulation.

1.4 Precautions against inlet of gases or vapours

1.4.1 Suitable arrangements are to be provided, to the satisfaction of the Society, so as to prevent the possibility of gases or vapours passing from a gas-dangerous space to another space through runs of cables or their conduits.

2 Hazardous location classification and permitted electrical equipment

2.1 General

2.1.1 Units are to be assessed with regard to any potential explosive gas atmosphere in accordance with the provisions of [2] or alternatively with an acceptable Code or Standard giving equivalent safety.

2.1.2 The results are to be documented in area classification drawings to allow the proper selection of all electrical components to be installed.

2.1.3 The hazardous location classification is to be carried out by those who have knowledge of the properties of flammable materials, the process and the equipment, in consultation with, as appropriate, safety, electrical, mechanical and other engineering personnel.

2.1.4 Classification of hazardous areas in ZONES is defined in Pt C, Ch 2, Sec 1, [3.24] of the Rules for the Classification of Ships.

2.1.5 Release as a result of accidental events such as blow-out or vessel rupture is not addressed by area classification. It is to be covered by emergency measures.

2.1.6 Openings, penetrations or connections between areas of different hazardous area classification are to be avoided, e.g. through ventilation systems, air pipes or drain systems.

2.1.7 Enclosed or semi-enclosed spaces (not containing a source of hazard) having a direct opening, including those for ventilation, into any hazardous area are to be designated as the same hazardous zone as the area in which the opening is located. See also [2.1.6] and [2.1.9]. Electrical installations are to comply with the requirements for the space or area into which the opening leads.

2.1.8 Electrical installations in spaces protected by airlocks are to be of a certified safe type unless arranged to be de-energised upon loss of overpressure in the space.

2.1.9 (1/1/2021)

Except for operational reasons, access doors or other openings are not to be provided between a non-hazardous space and a hazardous area or between a zone 2 space and a

zone 1 space. Where such access doors or other openings are provided, any non-hazardous enclosed space having a direct access to any zone 1 location or zone 2 location becomes the same zone as the location except that:

- a) an enclosed space with direct access to any zone 1 location can be considered as zone 2 if:
 - the access is fitted with a self-closing gastight door opening into the zone 2 space, and
 - ventilation is such that the air flow with the door open is from the zone 2 space into the zone 1 location, and
 - loss of ventilation is alarmed at a manned station;
- b) an enclosed space with direct access to any zone 2 location is not considered hazardous if:
 - the access is fitted with a self-closing gastight door that opens into the non-hazardous location, and
 - ventilation is such that the air flow with the door open is from the non-hazardous space into the zone 2 location, and
 - loss of ventilation is alarmed at a manned station.

For safety reasons doors are to be normally opened outwards.

- c) an enclosed space with direct access to any zone 1 location is not considered hazardous if:
 - the access is fitted with two self-closing gastight doors forming an airlock, and
 - the space has ventilation overpressure in relation to the hazardous space (see Note 1), and
 - loss of ventilation overpressure is alarmed at a manned station (see Note 1), and
 - the ventilation system shall be designed to maintain at least 50 Pa overpressure with respect to the external hazardous area when all penetrations are closed.

Note 1: An alarm delay of up to 30 s for loss of overpressure may be applied to minimize spurious alarms when doors are intentionally opened.

2.1.10 Where ventilation arrangements for the intended safe space are considered sufficient by the Society to prevent any ingress of gas from the zone 1 location, the two self-closing doors forming an airlock may be replaced by a single self-closing gastight door which opens into the non-hazardous location and has no hold-back device.

2.1.11 Piping systems are to be designed to preclude direct communication between hazardous areas of different classifications and between hazardous and non-hazardous areas.

2.2 Ventilation

2.2.1 For requirements of ventilation systems in hazardous areas, see Sec 12.

2.3 Hazardous area and electrical equipment

2.3.1 Electrical installations are to be such as to minimize the risk of fire and explosion from flammable products.

2.3.2 Electrical equipment and cables installed in hazardous areas are to be limited to those necessary for operational purposes.

2.3.3 Where electrical equipment is installed in gas-dangerous spaces or zones and is essential for operational purposes, it should be of a safe type for operation in the flammable atmosphere concerned.

2.3.4 Portable electrical equipment, supplied by cables is not permitted in hazardous areas, unless special precautions are taken (see IEC 61892-7 clause 6.5).

2.3.5 For FSRU the electrical equipment specified in Tab 1 may be installed in gas-dangerous spaces and areas indicated therein.

2.3.6 Tab 2 specifies temperature class and explosion group data for some products. The data shown in brackets have been derived from similar products.

2.3.7 For electrical cables see Pt C, Ch 2, Sec 2, [12.2].

2.3.8 The cross-section of cables installed in hazardous areas is to be correlated to the characteristics time/current of the relevant electrical protective device in order to limit the surface temperature of the cable to a safety value obliged by the temperature class of the dangerous gas likely to be present in the area, under the most severe expected fault condition.

2.3.9 Submerged cargo pumps are not permitted in connection with the following cargoes:

- diethyl ether;
- vinyl ethyl ether;
- ethylene oxide;
- propylene oxide;
- mixtures of ethylene oxide and propylene oxide.

2.3.10

- a) Where submerged electric motors are employed, means are to be provided, e.g. by the arrangements specified in paragraph 17.6 of the IGC Code, to avoid the formation of explosive mixtures during loading, cargo transfer and unloading.
- b) Arrangements are to be made to automatically shut down the motors in the event of low liquid level. This may be accomplished by sensing low pump discharge pressure, low motor current, or low liquid level. This shutdown is to be alarmed at the cargo control station. Cargo pump motors are to be capable of being isolated from their electrical supply during gas-freeing operations.

2.4 Process plant location classification and permitted electrical equipment

2.4.1 (1/1/2021)

Hazardous location classification is to be carried out in accordance with the following requirements and IEC 60079-10-1, or, alternatively, with an acceptable Code or Standard giving equivalent safety.

2.4.2 It is to be taken into consideration that the horizontal extent of the hazardous areas at ground level will increase with increasing relative density of the gas or vapour which may be released and the vertical extent above the source will increase with decreasing the gas or vapour relative density.

2.4.3 (1/1/2021)

Zone 0 hazardous location normally include areas or spaces:

- a) within process apparatus developing flammable gas or vapours;
- b) within enclosed pressure vessels or storage tanks;
- c) around vent pipes which discharges continually or for long periods;
- d) over/near surface of flammable liquids in general;
- e) areas inside atmospheric pressure vessels.

The zone 0 area referred to in a), b) and d) above is only applicable for equipment vented to the atmosphere.

2.4.4 (1/1/2021)

Zone 1 hazardous location normally include areas or spaces:

- a) with a certain radius around the outlet of vent and pressure relief valves venting to atmosphere of pressurized vessels containing hydrocarbon;
- b) around ventilation openings from a zone 1 area;
- c) around sample taking points (valves, etc.);
- d) around seals of pumps, compressors, and similar apparatus, if primary source of release and rooms without ventilation, with direct access from a zone 2 area;
- e) rooms or parts of rooms containing secondary sources of release, where internal outlets indicate zone 2, but where efficient dilution of an explosive atmosphere cannot be expected because of insufficient ventilation.

2.4.5 Zone 2 hazardous location normally include areas or spaces:

- a) around flanges, connections, valves, etc.;
- b) outside of zone 1, around the outlet of vent pipes, pipelines and safety valves;
- c) around vent openings from the zone 2 area;
- d) between the main deck and the production/facilities deck, unless installations on the deck result in a zone 1 area classification.

2.4.6 (1/1/2020)

The following provisions are to be taken into account.

- a) Pipelines without flanges, connections, valves or other similar fittings need not be regarded as a source of release.
- b) Certain areas and spaces (rooms) are, if so indicated by the circumstances, to be classified as a more hazardous zone than set out in these examples.
- c) Certain areas and spaces (rooms) may, under certain circumstances and/or when special precautions are taken,

be classified as a less hazardous zone than indicated by these examples. Such special circumstances may be, for example, redundant ventilation arrangements.

- d) Enclosed rooms, without ventilation, with openings to an area with explosion risks, are to be classified as the same, or as a more hazardous zone than such an area.

2.4.7 Electrical installations are to be such as to minimize the risk of fire and explosion from flammable products.

2.4.8 Electrical equipment and cables installed in hazardous areas are to be limited to those necessary for operational purposes.

2.4.9 Where electrical equipment is installed in gas-dangerous spaces or zones and is essential for operational purposes, it should be of a safe type for operation in the flammable atmosphere concerned.

2.4.10 Portable electrical equipment, supplied by cables is not permitted in hazardous areas, unless special precautions are taken (see IEC 61892-7 clause 6.5).

2.4.11 Permitted electrical equipment, in hazardous location defined according to [2.4], is that indicated in Pt C, Ch 2, Sec 2, [12.1.4] to [12.1.6] as applicable.

2.4.12 The explosion group and temperature class of electrical equipment of a certified safe type are to be chosen taking into account the more demanding of the required explosion groups and temperature classes of the hazardous product whose gas or vapour may be present at the location.

2.4.13 For electrical cables see Pt C, Ch 2, Sec 2, [12.2].

2.4.14 The cross-section of cables installed in hazardous areas is to be correlated to the characteristics time/current of the relevant electrical protective device in order to limit the surface temperature of the cable to a safety value obliged by the temperature class of the dangerous gas likely to be present in the area, under the most severe expected fault condition.

3 Sources of electrical power and distribution systems

3.1 Power sources location

3.1.1 (1/1/2021)

Sources of electrical power and their main/emergency switchboards and distribution boards, are, to the extent possible, not be located in hazardous areas.

3.1.2 (1/1/2021)

The generating plant, switchboards and batteries are to be separated from any zone 0 by cofferdams or equivalent spaces and from other hazardous areas by gas-tight steel divisions or in areas protected by overpressure.

Access between such spaces have to comply with [2.1.9].

Table 1 : FSRU hazardous location classification and permitted electrical equipment

Hazardous area	Spaces		Electrical equipment
	N°	Description	
Zone 0	1	Cargo containment systems: Interior of cargo tanks, slop tanks, any pipework of pressure relief or other venting systems for cargo and slop tanks, pipes and equipment containing cargo or developing flammable gases or vapours.	<ul style="list-style-type: none"> a) certified intrinsically safe apparatus Ex(ia); b) simple electrical apparatus and components (e.g. thermocouples, photocells, strain gauges, switching devices), included in intrinsically safe circuits of category "ia" not capable of storing or generating electrical power or energy in excess of limits stated in the relevant standards c) equipment specifically designed and certified by the appropriate authority for use in Zone 0 d) submerged cargo pump motors and their supply cables may be fitted in cargo containment systems.
Zone 0	2	Interbarrier spaces, hold spaces where cargo is carried in a cargo containment system requiring a secondary barrier.	<ul style="list-style-type: none"> a) certified intrinsically safe apparatus Ex(ia); b) simple electrical apparatus and components (e.g. thermocouples, photocells, strain gauges, switching devices), included in intrinsically safe circuits of category "ia" not capable of storing or generating electrical power or energy in excess of limits stated in the relevant standards; c) equipment specifically designed and certified by the appropriate authority for use in Zone 0; d) supply cables for submerged cargo pump motors.
Zone 1	3	Hold spaces where cargo is carried in a cargo containment system not requiring a secondary barrier	<ul style="list-style-type: none"> a) any type considered for Zone 0; b) certified intrinsically safe apparatus Ex(ib); c) simple electrical apparatus and components (e.g. thermocouples, photocells, strain gauges, switching devices), included in intrinsically safe circuits of category "ib" not capable of storing or generating electrical power or energy in excess of limits stated in the relevant standards; d) electrical cables passing through the spaces. e) lighting fittings are to have pressurised enclosures Ex(p) or to be of the flameproof type Ex(d). The lighting system is to be divided between at least two branch circuits. All switches and protective devices are to interrupt all poles or phases and are to be located in a gas-safe space; f) hull fittings containing the terminals or shell plating penetrations for anodes or electrodes of an impressed current cathodic protection system, or transducers such as those for depth sounding or log systems, provided that such fittings are of gas-tight construction or housed within a gas-tight enclosure and are not located adjacent to a cargo tank bulkhead. The design of such fittings or their enclosures and the means by which cables enter, and any testing to establish their gas-tightness, are to be to the satisfaction of the Society.
Zone 1	4	Spaces separated from a hold space where cargo is carried in a cargo containment system requiring a secondary barrier by a single gas-tight steel boundary.	<ul style="list-style-type: none"> a) any type considered for spaces under item 3; b) flameproof motors for valve operation for cargo or ballast systems; c) flameproof general alarm audible indicators.

Hazardous area	Spaces		Electrical equipment
	N°	Description	
Zone 1	5	Cargo pump and cargo compressor rooms.	<p>a) any type considered for Zone 0;</p> <p>b) certified intrinsically safe apparatus Ex(ib);</p> <p>c) simple electrical apparatus and components (e.g. thermocouples, photocells, strain gauges, switching devices), included in intrinsically safe circuits of category "ib" not capable of storing or generating electrical power or energy in excess of limits stated in the relevant standards;</p> <p>d) lighting fittings are to have pressurised enclosures Ex(p) or to be of the flameproof type Ex(d). The lighting system is to be divided between at least two branch circuits. All switches and protective devices are to interrupt all poles or phases and are to be located in a gas-safe space.</p> <p>e) electric motors for driving cargo pumps or cargo compressors are to be separated from these spaces by a gas-tight bulkhead or deck. Flexible couplings or other means of maintaining alignment are to be fitted to the shafts between the driven equipment and its motors and, in addition, suitable glands are to be provided where the shafts pass through the bulkhead or deck. Such electric motors and associated equipment are to be located in a compartment complying with Chapter 12 of the IGC Code;</p> <p>f) where operational or structural requirements are such as to make it impossible to comply with the method described in e), motors of the following certified safe types may be installed:</p> <ul style="list-style-type: none"> • increased safety type with flameproof enclosure Ex(de); and • pressurised type. <p>g) certified safe type visual and/or acoustic indicators (e.g. for general alarm, fire-extinguishing media alarm, etc.);</p> <p>h) certified safe type sensors for gas detection systems.</p>
Zone 1	6	Areas on open deck or semi-enclosed spaces on open deck, within 3 m of any cargo tank outlet, gas or vapour outlet, cargo manifold valve, cargo valve, cargo pipe flange, cargo pump room and cargo compressor room, ventilation outlets and cargo tank openings for pressure release provided to permit the flow of small volumes of gas or vapour mixtures caused by thermal variation.	<p>a) any type considered for Zone 0;</p> <p>b) certified intrinsically safe apparatus Ex(ib);</p> <p>c) simple electrical apparatus and components (e.g. thermocouples, photocells, strain gauges, switching devices), included in intrinsically safe circuits of category "ib" not capable of storing or generating electrical power or energy in excess of limits stated in the relevant standards;</p> <p>d) certified flameproof Ex(d);</p> <p>e) certified pressurised Ex(p);</p> <p>f) certified increased safety Ex(e);</p> <p>g) certified encapsulated Ex(m);</p> <p>h) certified sand filled Ex(q);</p> <p>i) electrical cables passing through the spaces.</p>
Zone 1	7	Areas on open deck, or semi-enclosed spaces on open deck above and in the vicinity of any cargo gas outlet intended for the passage of large volumes of gas or vapour mixture during cargo loading and ballasting or during discharging, within a vertical cylinder of unlimited height and 6 m radius centred upon the centre of the outlet, and within a hemisphere of 6 m radius below the outlet.	As allowed under item 6.

Hazardous area	Spaces		Electrical equipment
	N°	Description	
Zone 1	8	Areas on open deck, or semi-enclosed spaces on open deck within 1,5 m of cargo pump room entrances, cargo pump room ventilation inlet, openings into cofferdams or other zone 1 spaces.	As allowed under item 6.
Zone 1	9	Areas on open deck within spillage coamings surrounding cargo manifold valves and 3 m beyond these, up to a height of 2,4 m above the deck.	As allowed under item 6.
Zone 1	10	Areas on open deck over all cargo tanks (including all ballast tanks within the cargo tank area) where structures are restricting the natural ventilation and to the full breadth of the unit plus 3 m fore and aft of the forward-most and aft-most cargo tank bulkhead, up to a height of 2,4 m above the deck.	As allowed under item 6.
Zone 1	11	Compartments for cargo hoses.	<ul style="list-style-type: none"> a) any type considered for Zone 0; b) certified intrinsically safe apparatus Ex(ib); c) simple electrical apparatus and components (e.g. thermocouples, photocells, strain gauges, switching devices), included in intrinsically safe circuits of category "ib" not capable of storing or generating electrical power or energy in excess of limits stated in the relevant standards; d) lighting fittings are to have pressurised enclosures Ex(p) or to be of the flameproof type Ex(d). The lighting system is to be divided between at least two branch circuits. All switches and protective devices are to interrupt all poles or phases and are to be located in a gas-safe space. e) electrical cables passing through the spaces.
Zone 1	12	Enclosed or semi-enclosed spaces in which pipes containing cargoes are located.	As allowed under item 11.
Zone 2	13	Areas of 1,5 m surrounding open or semi-enclosed spaces of Zone 1 defined in item 6, 7, 9 and 10	<ul style="list-style-type: none"> a) any type considered for Zone 1; b) electrical equipment of a type which ensures the absence of sparks, arcs and "hot spots" during its normal operation; c) electrical equipment tested specially for Zone 2 (e.g. type "n" protection).
Zone 2	14	Air locks	As allowed under item 13.
Zone 2	15	Areas of 4 m beyond the cylinder and 4 m beyond the sphere defined in item 7	As allowed under item 13.
Zone 2	16	Areas on open deck extending to the coamings fitted to keep any spills on deck and away from the accommodation and service areas and 3 m beyond these up to a height of 2,4 m above the deck.	As allowed under item 13.
Zone 2	17	Areas on open deck over all cargo tanks (including all ballast tanks within the cargo tank area) where unrestricted natural ventilation is guaranteed and to the full breadth of the unit plus 3 m fore and aft of the forward-most and aft-most cargo tank bulkhead, up to a height of 2,4 m above the deck surrounding open or semi-enclosed spaces of zone 1.	As allowed under item 13.

Hazardous area	Spaces		Electrical equipment
	N°	Description	
Zone 2	18	Spaces forward of the open deck areas to which reference is made in item 10 and item 17, below the level of the main deck, and having an opening on the main deck or at a level less than 0,5m above the main deck, unless: a) the entrances to such spaces do not face the cargo tank area and, together with all other openings to the spaces, including ventilation system inlets and exhausts, are situated at least 5m from the foremost cargo tank and at least 10m measured horizontally from any cargo tank outlet or gas or vapour outlet; and b) the spaces are mechanically ventilated.	As allowed under item 13.
Zone 2	19	An area within 2,4 m of the outer surface of a cargo tank where such surface is exposed to the weather.	As allowed under item 13.

Table 2 : Temperature class and explosion group of certain products

Product name	Temperature class	Explosion group	Product name	Temperature class	Explosion group
Acetaldehyde	T4	II A	Methane	T1	II A
Ammonia anhydrous	T1	II A	Methyl acetylene propadiene mixture	T4	II A
Butadiene	T2	II B	Methyl bromide	T3	II A
Butane	T2	II A	Methyl chloride	T1	II A
Butane/propane mixture	T2	II A	Monoethylamine	T2	II A
Butylenes	T3	II A	Nitrogen	NF	NF
Chlorine	NF	NF	Pentane (all isomers)	(T2)	(II A)
Diethyl ether	T4	II B	Pentene (all isomers)	(T3)	(II B)
Dimethylamine	T2	II A	Propane	T2	II A
Ethane	T2	II A	Propylene	T2	II B
Ethyl chloride	T2	II A	Propylene oxide	T2	II B
Ethylene	T2	II B	Refrigerant gases	NF	NF
Ethylene oxide	T2	II B	Sulphur dioxide	(T3)	(II B)
Ethylene oxide propylene oxide mixture (max. 30% mass/mass ethylene oxide)	T2	II B	Vinyl chloride	T2	II A
Isoprene	T3	II B	Vinyl ethyl ether	T3	II B
Isopropylamine	T2	II A	Vinylidene chloride	T2	II A

SECTION 11

SAFETY SYSTEM AND FIRE PROTECTION

1 Fire and gas detection

1.1 General

1.1.1 Reference is to be made to Sec 13, [6] and Pt C, Ch 4, Sec 2, [6].

2 Emergency shut down system

2.1 Drawings to be submitted

2.1.1 The following documentation is to be sent for approval:

- a) diagrams of emergency shutdown circuits
- b) cause and effects diagrams.

2.2 General requirements and definitions

2.2.1 The safest conditions for the systems on board are to be defined.

2.2.2 All equipment and systems are to be equipped with indicating or monitoring instruments and devices necessary for safe operation.

2.2.3 Emergency shutdown systems are to be provided against hazardous events.

Production systems are to be equipped with shutdown systems.

Systems that could endanger the safety if they fail or operate outside pre-set conditions are to be provided with automatic shutdown.

2.2.4 An emergency shutdown system (ESD) includes:

- a) manual input devices (push buttons)
- b) interfaces towards other safety systems, e.g.:
 - fire detection system
 - gas detection system
 - alarm and communication systems
 - process shutdown system
 - fire-fighting systems
 - ventilation systems
- c) a central control unit receiving and evaluating signals from the manual input devices and the interfaced systems, and creating output signals to devices that are to be shut down or activated. The ESD central control unit is to include a device providing visual indication of ini-

tiated inputs and activated outputs and a local audible alarm

- d) output actuators, e.g. relays, valves and dampers, including status indicators
- e) signal transfer lines between the ESD central control unit and all input devices, interfaced systems and output actuators
- f) power supply.

2.2.5 In the context of these requirements under [2], 'circuit' is defined as any signal transfer facility, e.g. electrical, pneumatic, hydraulic, optical or acoustic.

2.2.6 A normally energised circuit is a circuit where energy is present, e.g. an electrical current or pneumatic or hydraulic pressure, when the circuit is not activated by the shutdown system.

2.2.7 A normally de-energised circuit is a circuit where energy is not present when the circuit is not activated by the shutdown system.

2.3 Basic design principles

2.3.1 All shutdowns are to be executed in a predetermined logical manner. The shutdown system is normally to be designed in a hierarchical manner where higher level shutdowns automatically initiate lower level shutdowns.

2.3.2 Definition of the shutdown logic and required response times are to be based on consideration of dynamic effects and interactions between systems.

2.3.3 Shutdown is not to result in adverse cascade effects, which depends on activation of other protection devices to maintain a plant in a safe condition.

2.3.4 The shutdown system is to be designed to ensure that any ongoing operations can be terminated safely when a shutdown is activated.

2.3.5 Inter-trips between process systems are to be initiated as a result of any initial event which could cause undesirable cascade effects in other parts of the plant before operator intervention can be realistically expected.

2.3.6 Emergency shutdown is to initiate a process shutdown.

2.3.7 The shutdown system is to be completely independent of control systems used for normal operation. See also Pt C, Ch 3, Sec 2, [1.1.4] of the Rules for the Classification of Ships.

2.3.8 The shutdown system is to be capable to monitor critical parameters and bring the system to a safe condition

if specified conditions are exceeded. See also Pt C, Ch 3, Sec 2, [7] of the Rules for the Classification of Ships.

2.3.9 The system is to be designed so that the risk of unintentional shutdown caused by malfunction or inadvertent operation is minimised.

2.3.10 The system is to be designed to allow testing without interrupting other systems on board.

2.3.11 The central control unit is to be located in a non-hazardous and continuously manned area.

2.3.12 The system is to be powered from a monitored Uninterruptible Power Supply (UPS) capable of at least 30 minutes continuous operation on loss of its electrical power supply systems. The UPS is to be powered from both the main and the emergency power system.

2.4 Design and functional requirements

2.4.1 Upon failure of the shutdown system, all connected systems are to default to the safest condition [2.1.1] for the unit or installation.

2.4.2 Failures to be considered for the shutdown system are to include broken connections and short-circuits on input and output circuits, loss of power supply and, if relevant, loss of communication with other systems.

2.4.3 For a shutdown system with only normally energized outputs, all inputs are to be normally energized.

2.4.4 For a shutdown system with one or more normally de-energized outputs, all inputs able to activate a normally de-energized output are to be normally de-energized. All normally de-energized input and output circuits are to be monitored for broken connection and short-circuit.

2.4.5 Shutdown is not to require unrealistically quick or complex intervention by the operator.

2.4.6 Shutdowns on a hierarchical level are automatically to include shutdowns on lower levels.

2.4.7 Shutdown is to initiate alarm at the control station. The initiating device and operating status of devices affected by the shutdown action are to be indicated at the control station (e.g. valve position, unit tripped, etc.).

2.4.8 Personnel lifts, work platforms and other man-riding equipment are to be designed to enable safe escape after an emergency shutdown, e.g. by controlled descent to an access point on a lower level.

2.4.9 Systems which are not permanently attended during operation, and which could endanger safety if they fail, are to be provided with automatic safety control, alert and alarm systems.

2.4.10 Plants that are protected by automatic safety systems are to have pre-alarms to alert when operating parameters are exceeding normal levels.

2.4.11 -

The shutdown commands are not to be automatically reset.

In case local resets on shut down devices are provided, the indication of the shut down device status is to be given at the main control room.

2.5 Automatic and manual shutdown

2.5.1 Shutdowns are normally to be automatically initiated, however solely manually initiated actions may be provided where automatic action could be detrimental to safety.

2.5.2 Systems designed for automatic shutdown are also to be designed to enable manual shutdown.

2.5.3 Alarms for manual initiation are to be clear and are to be readily identifiable at a permanently manned control station.

2.5.4 In all shutdown systems, it is to be possible to manually activate all levels of shutdown at the control station.

2.5.5 Other manual shutdown buttons are to be located at strategic locations on the unit or installation.

2.6 Electrical equipment for use in an emergency

2.6.1 The following systems are to be operable after abandon unit shutdown:

- a) emergency lighting, for half an hour at:
 - every embarkation station on deck and over sides
 - in all service and accommodation alleyways, stairways and exits, personnel lift cars, and personnel lift trunks
 - in machinery spaces and main generating stations including their control positions
 - in all control stations and machinery control rooms
- b) general alarm
- c) public address
- d) battery supplied radio-communication.

2.6.2 Electrical equipment left operational after abandon unit shutdown is to be suitable for operation in zone 2 areas with the exceptions given in [2.3.7].

2.6.3 Electrical equipment located in non-hazardous areas affected by a gas release, which is left operational after gas detection is to be suitable for zone 2, with the exceptions given in [2.3.7].

2.6.4 Safety critical, uncertified electrical equipment may be left operational after ESD or gas detection affecting its area of location, provided that:

- the ventilation to the room where the equipment is located is isolated
- gas detectors are installed in the room where the equipment is located
- facilities for manual shutdown of the equipment are available.

3 Fire protection, detection and extinction

3.1 General

3.1.1 The requirements of this item [3] are not applicable for the purpose of classification, except where the Society carries out surveys relevant to fire protection statutory requirements on behalf of the flag Administration. In such cases, fire protection statutory requirements are considered a matter of class and therefore compliance with these requirements is also verified by the Society for classification purposes.

3.1.2 The following requirements apply in addition to those contained in this item [3]:

- a) Chapter 11 of the IGC Code; and
- b) Pt C, Ch 4, Sec 2, [1.2], [1.3], [1.4], [1.5], [3.2.1] b), [4.4], [5.1.1] a), [5.1.3] a) and b), [5.3], [5.5] and [5.7.4].

3.2 Water spray system

3.2.1 -

IGC CODE REFERENCE : Ch 11, 11.3

- a) Areas covered

The following areas are also to be covered by the system:

- loading arm areas;
- turret areas;
- process facilities and equipment.

- b) Automatic intervention

The need for automatic intervention of the system, or a section of the same, is evaluated by the Society on a case-by-case basis. Manual activation is to be provided.

- c) Water availability

The capacity of the water pumps is to be adequate to the worst fire scenario likely to be encountered.

The scenario is to be evaluated upon case-by-case considerations taking account of the actual layout of the protected areas.

Where suitable fire-resistant divisions or adequate distances are arranged between sections, consideration may be given to decreasing the required amount of water.

SECTION 12

MECHANICAL VENTILATION IN THE CARGO AREA

1 General

1.1 Application

1.1.1 Requirements set out in Pt C, Ch 4, [3.5.1] d), [3.5.2] and [3.6] are to be apply, as pertinent, in addition to those contained in this section.

2 Spaces required to be entered during normal cargo handling operations

2.1 Location of discharges from dangerous spaces

2.1.1 Ventilation duct arrangement

IGC CODE REFERENCE : Ch 12, 12.1.6

- a) Ventilation ducts are to be arranged at a suitable height from the weather deck. This height is not to be less than 2,4 m for intake ducts.
- b) Ventilation ducts are to be fitted with metallic fire dampers provided with "open" and "closed" signs. These dampers are to be arranged in the open, in a readily accessible position.
- c) Gas-dangerous spaces for the purpose of 1.1.1.a) are those mentioned in paragraph 12.1.5 of the IGC Code. For other spaces which are gas-dangerous only due to their position, some relaxation may be granted.

2.2 Recirculation prevention

2.2.1

IGC CODE REFERENCE : Ch 12, 12.1.7

- a) Exhaust ducts from gas-dangerous spaces are to be arranged at a distance in the horizontal direction of at least 10 m from ventilation outlets of gas-safe spaces. Shorter distances may be accepted for ventilation outlets from safe spaces protected by air-locks.
- b) Intakes of gas-dangerous spaces are to be arranged at a distance in the horizontal direction of at least 3 m from ventilation intakes and outlets and openings of accommodation spaces, control stations and other gas-safe spaces.
- c) Exhaust and intake ducts for the same gas-dangerous space, or for the same space rendered safe by an air-lock, are to be arranged at a distance from each other in the horizontal direction of not less than 3 m.

3 Spaces not normally entered

3.1 General requirements

3.1.1 Minimum number of air changes

IGC CODE REFERENCE : 12, 12.2

Both fixed and portable systems are to guarantee the efficient ventilation of such spaces in relation to the relative density, in respect of the air, and to the toxicity of the gases transported. Such ventilation system is to be capable of effecting not less than 8 air changes per hour. The type of portable fans and their connection to the spaces served are to be approved by the Society. In no case are portable electrical fans acceptable.

SECTION 13

INSTRUMENTATION (GAUGING, GAS DETECTION)

1 General

1.1 Cargo tank instrumentation

1.1.1 The instrumentation is to be of a type approved by the Society.

1.2 Detection of leak through secondary barrier

1.2.1

IGC CODE REFERENCE : Ch. 13, 13.1.2

Upon special approval, appropriate temperature indicating devices may be accepted by the Society instead of gas detecting devices when the cargo temperature is not lower than -55°C .

1.3 Indicator location

1.3.1 Monitoring list

IGC CODE REFERENCE : Ch. 13, 13.1.3

A "cargo control room" as dealt with in [3.4.1] of IGC Code is to be provided.

- a) The following information and alarms relevant to the containment, handling and process systems are to be transferred in the "cargo control room":
- 1) the indication signalling the presence of water and/or liquid cargo in holds or interbarrier spaces
 - 2) the alarm signalling the presence of liquid cargo in the vent main as per 5.2.1.7 of the IGC Code
 - 3) the indication of the hull temperature and the hull structure low temperature alarm required in 13.5.2 of the IGC Code
 - 4) the alarm signalling the automatic shutdown of electrically driven submerged pumps required in 10.2.2 of the IGC Code
 - 5) the indication of the cargo level and the cargo tank high level alarm required in 13.3.1 of the IGC Code
 - 6) the indication of the vapour space pressure and the vapour space pressure gauges of each cargo tank

and associated high and low pressure alarms required in 13.4.1 of the IGC Code

- 7) the gas detection equipment alarm required in 13.6.4 of the IGC Code
 - 8) the indication of the status of all gas compressors with regard to pressures and temperatures
 - 9) the indication of the status of all vaporizers and heaters with regard to all pressures and temperatures
 - 10) the indication of the status of the regasification plant with regard to all pressures and temperatures
- b) The high level and high or low pressure audible and visual alarms for cargo tanks as per 13.3.1 and 13.4.1 of the IGC Code and the alarm signalling the presence of liquid in the vent main are to be located in such a position as to be clearly heard and identifiable by the personnel in charge of loading operation control.

2 Level indicators for cargo tanks

2.1 General

2.1.1

IGC CODE REFERENCE : Ch. 13, 13.2.1

- a) In order to assess whether or not one level gauge is acceptable, the wording "any necessary maintenance" is to be interpreted to mean that any part of the level gauge can be overhauled while the cargo tank is in service.
- b) Where level gauges containing cargo are arranged outside the tank they serve, means are to be provided to shut them off automatically in the event of failure.

3 Overflow control

3.1 Overflow alarm and shutdown

3.1.1 Shut-off valve for overflow control

IGC CODE REFERENCE : Ch. 13, 13.3.1

The sensor for automatic closing of the loading valve for overflow control may be combined with the liquid level indicators required by paragraph 13.2.1 of the IGC Code.

3.1.2 Shut-off valve closing time -

IGC CODE REFERENCE : Ch. 13, 13.3.1

The closing time of the valve referred to in 13.3.1 in seconds (i.e. time from shutdown signal initiation to complete valve closure) is to be not greater than:

$$\frac{3600 \cdot U}{LR}$$

where:

U : Ullage volume at operating signal level (m³)

LR : Maximum loading rate agreed between unit and shuttle tankers (m³/h)

The loading rate is to be adjusted to limit surge pressure on valve closure to an acceptable level taking into account the loading hose or arm, and the unit and shuttle tanker piping systems, where relevant.

4 Pressure gauges

4.1 Pressure gauges in cargo tanks

4.1.1

IGC CODE REFERENCE : Ch. 13, 13.4.1

The low pressure alarm indicated in paragraph 13.4.1 of the IGC Code is also to be located in the cargo control room.

5 Temperature indicating devices

5.1 General

5.1.1 Temperature recording

IGC CODE REFERENCE : Ch. 13, 13.5.1

The temperatures are to be continuously recorded at regular intervals. Audible and visual alarms are to be automatically activated when the hull steel temperature approaches the lowest temperature for which the steel has been approved.

6 Gas detection requirements

6.1 Position of sampling heads

6.1.1

IGC CODE REFERENCE : Ch. 13, 13.6.2

Requirements set out in Part C, Ch 4, Sect 2, [6.2.2] apply.

6.2 Gas sampling lines

6.2.1

IGC CODE REFERENCE : Ch. 13, 13.6.5

Requirements set out in Pt C, Ch 4, Sect 2, [6.2.2] apply.

6.3 Protected spaces

6.3.1

IGC CODE REFERENCE : Ch. 13, 13.6.7

In addition to the list in paragraph 13.6.7 of the IGC Code, the gas detection system is also to serve:

- spaces adjacent to pump rooms and compressor rooms
- areas where process equipment are located including gas compressors and turret areas
- air locks and doorways to enclosed non hazardous areas;
- intakes for ventilation air, and
- ventilation outlets from hazardous areas mechanically ventilated.

6.4 Portable gas detectors

6.4.1

IGC CODE REFERENCE : Ch. 13, 13.6.13

For units intended to store toxic and flammable gases, two sets for toxic gases and two sets for flammable gases are to be provided.

SECTION 14

PROTECTION OF PERSONNEL

1 Personnel protection requirements for individual products

1.1 Showers and eye wash

1.1.1

IGC CODE REFERENCE : Ch 14, 14.4.3

The showers and eye wash are to be fitted with a heating system, or other suitable installation, in order to avoid any ice formation in their piping.

SECTION 15

FILLING LIMITS FOR CARGO TANKS

1 General

1.1

1.1.1 This Section is void, as there are no additional or alternative requirements to those indicated in Chapter 15 of the IGC Code.

SECTION 16

USE OF CARGO AS FUEL

1 Gas fuel supply

1.1 Piping

1.1.1 Piping runs

IGC CODE REFERENCE : Ch. 16, 16.3.1

- a) The main gas line between the gas make-up station and the machinery space is to be as short as possible.
- b) The gas piping is to be installed as high in the space as possible and at the greatest possible distance from the unit's hull.

1.1.2 Segregation of piping

IGC CODE REFERENCE : Ch. 16, 16.3.1

Gas piping is to be independent of other systems and may only be used for the conveyance of gas. It is to be ensured by its arrangement that it is protected against external damage.

1.1.3 Earthing

IGC CODE REFERENCE : Ch. 16, 16.3.1

Gas piping is to be suitably earthed.

1.1.4 Testing

IGC CODE REFERENCE : Ch. 16, 16.3.1

Piping, valves and fittings are to be hydrostatically tested, after assembly on board, to 1,5 times the working pressure but to not less than 0,7 MPa. Subsequently, they are to be pneumatically tested to ascertain that all the joints are perfectly tight.

1.2 Valves

1.2.1 Manual operation

IGC CODE REFERENCE : Ch. 16, 16.3.6

The three valves indicated in paragraph 16.3.6 of the IGC Code are to be capable of being manually operated.

1.2.2 Automatic operation

IGC CODE REFERENCE : Ch. 16, 16.3.6

It is to be possible to operate the valves indicated in paragraph 16.3.6 of the IGC Code locally and from each control platform. They are to close automatically under the following service conditions:

- a) whenever the gas pressure varies by more than 10 % or, in the case of supercharged engines, if the differential pressure between gas and charging air is no longer constant
- b) in the event of one of the following fault situations:
 - 1) Gas supply to boiler burners
 - insufficient air supply for complete combustion of the gas
 - extinguishing of the pilot burner for an operating burner, unless the gas supply line to every indi-

vidual burner is equipped with a quick-closing valve that automatically cuts off the gas

- low pressure of the gas
- 2) Gas supply to internal combustion engines
 - failure of supply to pilot fuel injection pump
 - drop of engine speed below the lowest service speed
 - indication by the gas detector in the crankcase vent line that the gas concentration is approaching the lower explosion limit.

2 Gas make-up plant and related storage tanks

2.1 General

2.1.1 Location of equipment for making up gas

IGC CODE REFERENCE : Ch. 16, 16.4.1

Means for purging of flammable gases before opening are to be provided in the equipment for making up gas.

2.1.2 Equipment located on weather deck

IGC CODE REFERENCE : Ch. 16, 16.4.1

Where the equipment (heaters, compressors, filters) for making up the gas for its use as fuel and the storage tanks are located on the weather deck, they are to be suitably protected from atmospheric agents and the sea.

2.2 Compressors

2.2.1 Miscellaneous requirements -

IGC CODE REFERENCE : Ch. 16, 16.4.2

- a) The compressors are to be capable of being remotely stopped from an always and easily accessible, safe position in the open, and also from the engine room.
- b) In addition, the compressors are to be capable of automatically stopping when the suction pressure reaches a certain value depending on the setting pressure of the vacuum relief valves of the cargo tanks.
- c) The automatic shutdown device of the compressors is to have a manual resetting.
- d) Piston-type compressors are to be fitted with relief valves discharging to a position in the open, such as not to give rise to hazards.
- e) Volumetric compressors are to be fitted with anti-surge relief valves, or equivalent devices, discharging into the suction line of the compressor.
- f) The size of the pressure relief valves is to be determined in such a way that, with the delivery valve kept closed, the maximum pressure does not exceed the maximum working pressure by more than 10%.
- g) The compressors are to be fitted with shut-off valves on both the suction and delivery sides.

2.3 Heaters

2.3.1 Additional miscellaneous requirements

IGC CODE REFERENCE : Ch. 16, 16.4.3

- a) Operation of the heaters is to be automatically regulated depending on the gas temperature at the heater outlet.
- b) Before it is returned to the machinery space, the heating medium (steam or hot water) is to go through a degassing tank located in the cargo area.
- c) Provisions are to be made to detect and signal the presence of gas in the tank. The vent outlet is to be in a safe position and fitted with a flame screen.

3 Special requirements for boilers

3.1 Boiler arrangement

3.1.1 Forced air circulation

IGC CODE REFERENCE : Ch. 16, 16.5.1

Boilers are to be located as high as possible in boiler spaces and are to be of the membrane wall type or equivalent, so as to create a space with forced air circulation between the membrane wall and the boiler casing .

3.2 Combustion chamber

3.2.1 Gas detectors in the combustion chamber

IGC CODE REFERENCE : Ch. 16, 16.5.3

The Society may, at its discretion, require gas detectors to be fitted in those combustion chamber areas where gas could accumulate, as well as the provision of suitable air nozzles.

3.3 Burner system

3.3.1 Safety devices

IGC CODE REFERENCE : Ch. 16, 16.5.4

A mechanical device is to be installed to prevent the gas valve from opening until the air and the fuel oil controls are in the ignition position. A flame screen, which may be incorporated in the burner, is to be fitted on the pipe of each gas burner.

3.3.2 Shut-off

IGC CODE REFERENCE : Ch. 16, 16.5.4

The gas supply is to be automatically stopped by the shut-off devices specified in paragraph 16.3.6 of the IGC Code.

4 Special requirements for gas fired internal combustion engines and gas fired turbines

4.1 Gas fuel supply to engine

4.1.1 Flame arresters

IGC CODE REFERENCE : Ch. 16, 16.6

Flame arresters are to be provided at the inlet to the gas supply manifold for the engine.

4.1.2 Manual shut-off

IGC CODE REFERENCE : Ch. 16, 16.6

Arrangements are to be made so that the gas supply to the engine can be shut off manually from the starting platform or any other control position.

4.1.3 Prevention of fatigue failure

IGC CODE REFERENCE : Ch. 16, 16.6

The arrangement and installation of the gas piping are to provide the necessary flexibility for the gas supply piping to accommodate the oscillating movements of the engines without risk of fatigue failure.

4.1.4 Protection of gas line connections

IGC CODE REFERENCE : Ch. 16, 16.6

The connecting of gas line and protection pipes or ducts as per Ch 9, Sec 16, [4.2.1] to the gas fuel injection valves is to provide complete coverage by the protection pipe or ducts.

4.2 Gas fuel supply piping systems

4.2.1 Fuel piping in machinery spaces

IGC CODE REFERENCE : Ch. 16, 16.6

Gas fuel piping may pass through or extend into machinery spaces or gas-safe spaces other than accommodation spaces, service spaces and control stations provided that they fulfil one of the following conditions:

- a) The system complies with paragraph 16.3.1.1 of the IGC Code, and in addition, with 1, 2 and 3 below:
 - 1) The pressure in the space between concentric pipes is monitored continuously. Alarm is to be issued and the automatic valves specified in 16.3.6 of the IGC Code (hereafter referred to as "interlocked gas valves") and the master gas fuel valves specified in 16.3.7 of the IGC Code (hereafter referred to as "master gas valves") are to be closed before the pressure drops to below the inner pipe pressure (however, an interlocked gas valve connected to the vent outlet is to be opened).
 - 2) The construction and strength of the outer pipes are to comply with the requirements of 5.2 of the IGC Code.
 - 3) It is to be so arranged that the inside of the gas fuel supply piping system between the master gas valve and the engine is automatically purged with inert gas when the master gas valve is closed; or
- b) The system complies with paragraph 16.3.1.2 of the IGC Code, and in addition, with 1 to 4 below:
 - 1) The materials, construction and strength of protection pipes or ducts and mechanical ventilation systems are to be sufficiently durable against bursting and rapid expansion of high pressure gas in the event of gas pipe burst.
 - 2) The capacity of mechanical ventilating systems is to be determined considering the flow rate of gas fuel and construction and arrangement of protective pipes or ducts, as deemed appropriate by the Society.
 - 3) The air intakes of mechanical ventilating systems are to be provided with non-return devices effective for gas fuel leaks.

However, if a gas detector is fitted at the air intakes, this requirement may be dispensed with.

- 4) The number of flange joints of protective pipes or ducts is to be minimised; or
- c) Alternative arrangements to those given in a) and b) will be specially considered by the Society based upon an equivalent level of safety.

4.2.2 High pressure pipes

IGC CODE REFERENCE : Ch. 16, 16.6

High pressure gas piping systems are to be checked for sufficient constructive strength by carrying out stress analysis taking into account the stresses due to the weight of the piping system including acceleration load, when significant, internal pressure and loads induced by hog and sag of the unit.

4.2.3 Valves and expansion joints

IGC CODE REFERENCE : Ch. 16, 16.6

All valves and expansion joints used in high pressure gas fuel supply lines are to be of an approved type.

4.2.4 Pipe joints

IGC CODE REFERENCE : Ch. 16, 16.6

Joints on the entire length of the gas fuel supply lines are to be butt-welded joints with full penetration and to be fully radiographed, except where specially approved by the Society.

4.2.5 Non-welded pipe joints

IGC CODE REFERENCE : Ch. 16, 16.6

Pipe joints other than welded joints at the locations specifically approved by the Society are to comply with the appropriate standards recognised by the Society, or with joints whose structural strength has been verified through test analysis as deemed appropriate by the Society.

4.2.6 Post-weld heat treatment

IGC CODE REFERENCE : Ch. 16, 16.6

For all butt-welded joints of high pressure gas fuel supply lines, post-weld heat treatment is to be performed depending on the kind of material.

4.3 Shut-off of gas fuel supply

4.3.1 Fuel supply shut-off

IGC CODE REFERENCE : Ch. 16, 16.6

In addition to the causes specified in 16.3.6 of the IGC Code, supply of gas fuel to engines is to be shut-off by the interlocked gas valves in the event of the following abnormalities:

- a) abnormality specified in Pt C, Ch 1, App 2 of the Rules for the Classification of Ships
- b) engine stops due to any cause.

4.3.2 Master gas valve shut-off

IGC CODE REFERENCE : Ch. 16, 16.6

In addition to the causes specified in 16.3.7 of the IGC Code, the master gas valve is to be closed in the event of any of the following:

- a) the oil mist detector or bearing temperature detector specified in Pt C, Ch 1, App 2 of the Rules for the Classification of Ships detects abnormality
- b) any kind of gas fuel leakage is detected
- c) abnormality specified in Pt C, Ch 1, App 2 of the Rules for the Classification of Ships.

4.3.3 Automatic operation

IGC CODE REFERENCE : Ch. 16, 16.6

The master gas valve is to close automatically upon activation of the interlocked gas valves.

4.4 Emergency stop of dual fuel engines

4.4.1

IGC CODE REFERENCE : Ch. 16, 16.6

Dual fuel engines are to be stopped before the gas concentration detected by the gas detectors specified in 16.2.2 of the IGC Code reaches 60% of the lower flammable limit.

4.5 Gas fuel make-up plant and related storage tanks

4.5.1 Equipment construction

IGC CODE REFERENCE : Ch. 16, 16.6

The construction, control and safety system of high pressure gas compressors, pressure vessels and heat exchangers constituting a gas fuel make-up plant are to be arranged to the satisfaction of the Society.

4.5.2 Fatigue

IGC CODE REFERENCE : Ch. 16, 16.6

The possibility of fatigue failure of the high pressure gas piping due to vibration is to be considered.

4.5.3 Gas pressure pulsation

IGC CODE REFERENCE : Ch. 16, 16.6

The possibility of pulsation of gas fuel supply pressure caused by the high pressure gas compressor is to be considered.

4.6 Requirements on dual fuel engines

4.6.1

IGC CODE REFERENCE : Ch. 16, 16.6

Specific requirements on internal combustion engines supplied by gas are given in Pt C, Ch 1, App 2 of the Rules for the Classification of Ships.

SECTION 17

SPECIAL REQUIREMENTS

1 General

1.1

1.1.1 The Section is void, as there are no specific requirements applicable to **FSRU**.

SECTION 18

OPERATING REQUIREMENTS

1 General

1.1

1.1.1 This Section is void, as the provisions of Chapter 18 of the IGC Code are operating requirements which are not mandatory for the class, with exception of 18.8.2 which is referred to in Sec 13, [3.1.2].

SECTION 19

SUMMARY OF MINIMUM REQUIREMENTS

1 Additional information on products

1.1

1.1.1

IGC CODE REFERENCE - CHAPTER 19

Tab 1 lists some additional information for those products which are listed in the table in Chapter 19 of the IGC Code.

The list shown in Tab 1 gives properties for pure products. The specific gravity to be taken into account for the design of a unit might be altered considering the actual properties of the commercial product.

Information on temperature classes and explosion groups for electrical equipment in connection with the products to be stored is indicated in Sec 10, Tab 2.

Table 1

Product name	Boiling temperature (°C)	Specific gravity at boiling point (kg/m ³)	Ratio vapour/air density
Acetaldehyde	20,8	780	1,52
Ammonia, anhydrous	- 33,4	680	0,60
Butadiene	- 4,5	650	1,87
Butane	-0,5/11,7	600	2,02
Butylenes	- 6,3/- 7	625	1,94
Chlorine	- 34	1560	2,49
Diethyl ether	34,6	640	2,55
Dimethylamine	6,9	670	1,55
Ethane	- 88,6	549	1,04
Ethyl chloride	12,4	920	2,22
Ethylene	- 104	570	0,97
Ethylene oxide	-10,7	870	1,52
Isoprene	34,5	680	2,35
Isopropylamine	32,5	700	2,03
Methane (LNG)	-161,5	420	0,55
Methyl bromide	4,5	1730	3,27
Methyl chloride	-23,7	1000	1,78
Monoethylamine	16,6	690	1,56
Nitrogen	-196	808	0,97
Pentanes (all isomers)	36,1	610	2,6
Pentene (all isomers)	30,1/37	610	2,6
Propane	-42,3	580	1,56
Propylene	-47,7	610	1,50
Propylene oxides	34,5	860	2.00
Refrigerant gases			
Dichlorodifluoromethane (R12)	-30	1486	4,26
Dichloromonofluoroethane (R21)	8,9	1480	3,9
Dichlorotetrafluoroethane (R114)	3,8	1510	1,31
Monochlorodifluoromethane (R22)	-42	1420	2,98
Monochlorotetrafluoroethane (R124)	-	-	4,70
Monochlorotrifluoromethane (R13)	-81,4	1520	3,60
Sulphur dioxide	-10	1460	2,3
Vinyl chloride	-13,9	970	2,15
Vinyl ethyl ether	35,5	754	2,50
Vinylidene chloride	31,7	1250	3,45

SECTION 1	GENERAL
SECTION 2	HULL
SECTION 3	STABILITY
SECTION 4	MACHINERY
SECTION 5	ELECTRICAL INSTALLATIONS
SECTION 6	ELECTRIC PROPULSION PLANT
SECTION 7	AUTOMATION
SECTION 8	SAFETY SYSTEMS AND FIRE PROTECTION, DETECTION AND EXTINCTION
APPENDIX 1	IMPACT LOADS AND VORTEX SHEDDING
APPENDIX 2	FATIGUE ANALYSIS WITH DETERMINATION OF THE CUMULATIVE DAMAGE
APPENDIX 3	AN EXAMPLE OF ALTERNATIVE CRITERIA FOR A RANGE OF POSITIVE STABILITY AFTER DAMAGE OR FLOODING FOR COLUMN-STABILIZED SEMISUBMERSIBLE UNITS
APPENDIX 4	AN EXAMPLE OF ALTERNATIVE CRITERIA INTACT STABILITY CRITERIA FOR TWIN-PONTOON COLUMN-STABILIZED SEMISUBMERSIBLE UNITS

SECTION 1

GENERAL

1 General

1.1 Application

1.1.1 Units complying with the requirements of this Chapter are eligible for the assignment of the service notation **MODU**, as defined in Pt A, Ch 1, Sec 2, [4.5.1].

1.1.2 Units dealt with in this Chapter are to comply with the requirements stipulated in Part A, Part B, Part C and Part D, as applicable and with the requirements of this Chapter, which are specific to mobile offshore units engaged in drilling operations for the exploration or exploitation of resources beneath the seabed, such as liquid or gaseous hydrocarbons, sulphur or salt.

Some requirements of this Chapter apply to units having the notation **MODU** in lieu of, and not in addition to, the corresponding requirements of Parts B or C: each requirement for which this circumstance occurs is indicated in this chapter.

1.2 Summary table

1.2.1 Tab 1 indicates, for easy reference, the Sections of this Chapter dealing with requirements applicable to units having the notation **MODU**.

Table 1

Main subject	Reference
Hull and stability	Sec 2 and Sec 3
Machinery	Sec 4
Electrical installations	Sec 5
Electric propulsions plant	Sec 6
Automation	Sec 7
Fire protection, detection and extinction	Sec 8

1.3 Definition

1.3.1 Surface unit

A surface unit is a unit with a unit or barge-type displacement hull of single or multiple hull construction intended for operation in the floating condition.

In particular, surface type drilling units include:

a) Ship type drilling units

Ship type drilling units are seagoing ship-shaped units having a displacement type hull or hulls, of the single, catamaran or trimaran types, which have been designed or converted for drilling operations in the floating condition.

Such types of units are provided with propulsion machinery.

b) Barge type drilling units

Barge type drilling units are seagoing units having a displacement type hull or hulls, which have been designed or converted for drilling operations in the floating condition. Such types of units are not provided with propulsion machinery.

1.3.2 Self-elevating unit

A self-elevating unit is a unit with movable legs capable of raising its hull above the surface of the sea.

These units have hulls with sufficient buoyancy to safely transport the unit to the desired location; the hull is then raised to a predetermined elevation above the sea surface on its legs, which are supported by the sea-bed.

Drilling equipment and supplies may be transported on the unit, or may be added to the unit in its elevated position.

The legs of such units may penetrate the sea-bed, be fitted with enlarged sections or footings to reduce penetration, or be attached to a bottom pad or mat.

1.3.3 Column-stabilized unit

A column-stabilized unit is a displacement unit with the main deck connected to the underwater hull or footings by columns or caissons.

Such columns or caissons are of suitable scantlings and widely spaced such as to provide, together with the underwater hull or hulls, the necessary buoyancy and stability for all modes of operation afloat or the raising or lowering of the unit, as the case may be.

Bracing members of tubular or structural sections may be used to connect the columns, lower hulls or footings and to support the upper structure.

Drilling operations may be carried out in the floating condition, in which case the unit is described as a semisubmersible, or, when supported by the sea-bed, in which case the unit is described as a submersible. A semisubmersible unit may be designed to operate either floating or supported by the sea-bed, provided that both types of operation have been found to be satisfactory.

1.3.4 Other types of drilling units

Other types of drilling units are units which are designed as mobile offshore drilling units and which do not fall into the above-mentioned categories; these units are to be considered on a case by case basis.

1.3.5 Self-propelled unit

A self-propelled unit is a unit which is designed for unassisted passage. All other units are considered as non-self-propelled.

1.3.6 Modes of operation

Mode of operation means a condition or manner in which a unit may operate or function while on location or in transit.

The modes of operation of a unit subject to approval is to include at least the following:

a) Operating conditions

Conditions wherein a unit is on location for the purpose of conducting drilling operations, or similar operations (including small movements), and combined environmental and operational loadings are within the appropriate design limits established for such operations. The unit may be either afloat or supported on the sea-bed, as applicable.

b) Severe storm conditions

Conditions wherein a unit may be subjected to the most severe environmental loading for which the unit is designed.

Drilling operations or other industrial operations are assumed to have been discontinued due to the severity of the environmental loadings. The unit may be either afloat or supported on the sea-bed, as applicable.

c) Transit conditions

Conditions wherein a unit is moving from one geographical location to another.

1.3.7 Freeboard

Freeboard is the distance measured vertically downwards amidships from the upper edge of the deck line to the upper edge of the related load line.

1.3.8 Rule length

The Rules length L is:

- for ship type units, the distance, in m, on the summer load waterline from the foreside of the stem to the after-side of the rudder post or, if there is no rudder post, to the centre of the rudder stock. The length L is to be not less than 96 per cent and need not be greater than 97 per cent of the length on the summer load waterline. In the case of units with unusual stem or stern arrangements, the determination of the length L will be subject to special consideration;
- for barge type units, the distance, in m, measured on the centreline between the inside surfaces of the stem and stern structures on a waterline at 85 per cent of the depth D, excluding structural protrusions such as anchor rocks etc.;
- for other types of units, the distance, in m, measured from the fore end and the after end projected, if necessary, to the centreline of the unit;
- in the case of units without centreline, the determination of the length will be subject to special consideration.

1.3.9 Moulded breadth

The moulded breadth bis:

- For ship and barge type drilling units, the greatest horizontal distance, in m, between the inside of the outer

shell, measured perpendicularly to the centreline of the unit;

- for other types of units, the greatest overall transverse dimension, in m, measured perpendicularly to the centreline of the unit, excluding structural protrusions such as anchor rocks etc.;
- in the case of units without centreline, the determination of the breadth will be subject to special consideration.

1.3.10 Depth D

The depth D is:

- For ship and barge type drilling units, the vertical distance, in m, measured from the moulded base line to the moulded line of the weather deck at the middle of the length L;
- for other types of units, the vertical distance, in m, measured from the moulded base line to the moulded line of the uppermost continuous deck.

1.3.11 Moulded draught

The moulded draught T is the vertical distance, in m, measured from the moulded base line to the assigned load line which is determined according to load line regulations or on the basis of structural or stability considerations. Certain components of a unit's structure, machinery or equipment may extend below the moulded base line.

1.3.12 Moulded base line

The moulded base line is a horizontal line extending through the upper surface of the bottom shell plating of the hull or of the lowest hull or of the caisson of the unit.

1.3.13 Water depth

The water depth is the vertical distance, in m, from the seabed to the maximum water level, taking into account the effects of the astronomical, barometric and wind tide.

1.3.14 Light weight

The light weight is the weight of the complete unit with all its permanently installed machinery and systems, relevant equipment and outfits, including permanent ballast, spare parts normally retained on board, and liquids in machinery and systems at their normal working levels, but does not include liquids not necessary for the operation of machinery and systems, fuel in storage or reserve supply tanks, items of consumable or variable loads, persons on board and their effects.

1.3.15 Weathertight

Weathertight means that in any sea conditions water will not penetrate into the unit.

1.3.16 Watertight

Watertight means the capability of preventing the passage of water through the structure in any direction under a head of water for which the surrounding structure is designed.

1.3.17 Downflooding

Downflooding means any flooding of the interior of any part of the buoyant structure of a unit through openings which cannot be closed watertight or weathertight, as appropriate, in order to meet the intact or damage stability criteria, or which are required for operational reasons to be left open.

1.3.18 Normal operational and habitable conditions

Normal operational and habitable conditions means:

- a) conditions under which the unit as a whole, its machinery, services, means and aids ensuring safe navigation when under way, safety when in the industrial mode, fire and flooding safety, internal and external communications and signals, means of escape and winches for rescue boats, as well as the means of ensuring sufficiently comfortable conditions of habitability, are in working order and functioning normally; and
- b) drilling operations.

Note 1: Sufficiently comfortable conditions of habitability include at least adequate services for cooking, heating, air-conditioning, mechanical ventilation and fresh and sanitary water.

1.3.19 Gas-tight door

A gas-tight door is a solid, close-fitting door designed to resist the passage of gas under normal atmospheric conditions.

1.3.20 Main steering gear

The main steering gear is the machinery, the steering gear power units, if any, and ancillary equipment and the means of applying torque to the rudder stock, e.g. tiller or quadrant, necessary for effecting movement of the rudder for the

purpose of steering the unit under normal service conditions.

1.3.21 Auxiliary steering gear

The auxiliary steering gear is the equipment which is provided for effecting movement of the rudder for the purpose of steering the unit in the event of failure of the main steering gear.

1.3.22 Steering gear power unit

The steering gear power unit means:

- a) in the case of electric steering gear, an electric motor and its associated electrical equipment;
- b) in the case of electrohydraulic steering gear, an electric motor and its associated electrical equipment and connected pump;
- c) in the case of other hydraulic gear, a driving engine and connected pump.

1.3.23 Maximum ahead service speed

The maximum ahead service speed is the greatest speed which the unit is designed to maintain in service at sea at its deepest seagoing draught.

1.3.24 Maximum astern speed

The maximum astern speed is the speed which it is estimated the unit can attain at the designed maximum astern power at its deepest seagoing draught.

1.3.25 Diving system

A diving system is the plant and equipment necessary for the safe conduct of diving operations from a mobile offshore drilling unit.

SECTION 2

HULL

1 General analysis and design principles

1.1 Methods of analysis and calculation

1.1.1 Foreword

The determination of forces, moments, stresses and deflections as well as the definition of corresponding allowable values is to be based upon accepted principles of statics, dynamics and strength of materials and are to be in accordance with the requirements given in this Chapter.

The structural responses due to dynamic loadings are to be determined either by deterministic method or by stochastic method.

1.1.2 Deterministic dynamic analysis

This analysis may be performed either by the calculation of the motion of the unit due to the exciting forces given by the design wave or by a quasi-static analysis consisting of a calculation of the hydrodynamic forces acting on the unit assumed as steady and of the addition of inertia forces suitable, together with other acting loads, to achieve the static balance.

1.1.3 Stochastic dynamic analysis

This method consists of the calculation of the response function of the unit on regular waves, of the standard deviations on steady random waves (short term responses) and of the long term distribution of motions and stresses of the unit.

1.2 Design

1.2.1 General

The units are to be designed and constructed in order to minimize their sensitivity to the environmental actions and to loads during operation, in order to facilitate their construction and surveying.

Structural connections and nodes are to be designed to avoid, as far as practicable, complex structures and stress concentrations.

Units intended for operations in extreme cold areas are to be so arranged that water and ice cannot be trapped in structures or machinery.

In addition, means are to be provided to prevent fresh water, water ballast and intermediate tank fire-fighting water from freezing.

Structures which may be subjected to forces from alongside supply vessels or other floating units are to be locally strengthened and fitted with adequate fenders or sponsons.

The above is not necessary when special berthing and mooring arrangements preventing the structures from being subjected to forces from alongside supply vessels or other floating units are provided.

1.2.2 Units resting on the sea-bed

Units designed to rest on the sea-bed are to have sufficient positive downward gravity loadings on the support footings or mat to withstand the overturning moment of the most unfavourable combined environmental forces from any direction, with a reserve against the loss of positive bearing of any footing or segment of the area thereof, for each design loading condition.

Variable loads are to be considered in a realistic manner to the satisfaction of the Society.

Stabilizing and overturning moments are to be in compliance with the following equation:

$$M_{RRj} \geq K \cdot M_{Rj}$$

where:

- M_{RRj} : stabilizing moment due to the reactions of supporting structure and acting in the j direction
- M_{Rj} : overturning moment due to the combined environmental forces and acting in the j direction
- K : • safety factor against loss of vertical bearing capacity (scouring) and against loss of horizontal holding capacity (sliding) of any footing or segment in the area thereof
- 1,50, for operating loading condition
 - 1,25, for extreme loading condition.

1.2.3 Scantlings

Scantlings of the major structural elements of the unit are to be determined in accordance with the provisions of these Rules.

Scantlings of structural elements which are subject to local loads only, and which are not considered to be effective components of the primary structural frame of the unit, shall comply with the applicable requirements of the Rules.

- a) Where the unit is fitted with an adequate corrosion protection system, the scantlings may be determined on the basis of the provisions of [4] and taking account of allowable stresses given in [5]; in this case no corrosion allowance is required.
- b) Where no corrosion protection system is fitted or where the system is considered by the Society to be inadequate, an appropriate corrosion allowance is required on scantlings determined according to requirements given in [5] and [6] below.

Surface type drilling units are also to comply with the requirements in [6].

1.2.4 Equipment for mooring and anchoring

The transit condition is to be referred to for the evaluation of the relevant equipment for mooring and anchoring; the equipment required will be evaluated on a case by case basis.

2 Environmental conditions

2.1 General

2.1.1 In order to design a unit, all environmental phenomena which may produce loads acting on the structures are to be considered.

The environmental phenomena are to be considered both in the structural and in the stability analysis of the unit in all its anticipated conditions.

In order to design the unit, the environmental conditions are to be described in conjunction with the following types of reference conditions defined in Sec 1, [1.3]:

- operating and transit conditions which the operating environmental conditions are associated with;
- severe storm condition which the extreme environmental conditions are associated with.

2.2 Acceptability of the parameters defining the design environmental conditions

2.2.1 The parameters defining the design environmental conditions for which the unit is to be approved are to be based, where possible, upon significant statistical information relevant to the geographical operating and transit areas anticipated for the unit, obtained from statistics covering a sufficiently long period of time and supplied by recognized meteorologic-oceanographic institutes.

When the above-mentioned environmental parameters are based upon extrapolated data or upon forecasting methodologies other than those commonly used, sufficient theoretical information and technical know-how are to be supplied to the Society in order to demonstrate their soundness and their comparability with the official data.

When the available data are discordant, the parameters defining the design environmental conditions are to those which are most conservative.

2.3 Recurrence periods and environmental conditions

2.3.1 In order to design the unit structures, the statistical environmental conditions are to be split into the two following reference conditions:

- operating environmental conditions: the environmental conditions within which the normal industrial activity is performed. The recurrence period of such limiting conditions is to be established by the designer, approved by the Society and recorded in the Operating Manual.
- extreme environmental conditions: environmental conditions defined by a recurrence period as given in [3.1.2].

2.4 Parameters relevant to environmental phenomena

2.4.1 Wind

The parameters describing the wind conditions are to be obtained, where possible, on the basis of wind velocity statistics.

For the calculation of the loads due to wind, the statistics relevant to the two following types of wind velocity are to be considered:

- sustained wind velocity;
- gust wind velocity.

The sustained wind velocity is defined as the average wind velocity during a time interval of 1 minute.

The most probable highest sustained wind velocity relevant to an N years recurrence period is referred to as the N years sustained wind velocity".

The gust wind velocity is defined as the average wind velocity during a time interval of 3 seconds.

The most probable highest gust wind velocity relevant to an N years recurrence period is referred to as the N years gust wind velocity".

When data of the wind velocity versus height above the still water level are not available, the following equations may be used:

Sustained wind velocity at a height Z above the still water level:

$$V_{Z,C}(N) = V_{10,C}(N) \cdot (C_H)^{0.5}$$

Gust wind velocity at a height Z above the still water level:

$$V_{Z,R}(N) = V_{10,R}(N) \cdot (Z/10)^{0.085}$$

When $V_{10,R}(N)$ is unknown and only $V_{10,C}(N)$ is known, the following equation may be used:

$$V_{Z,R}(N) = V_{10,C}(N)[0.45 + (Z/10)^{0.085}]$$

where:

- $V_{Z,C}(N)$: N years sustained wind velocity at a height Z, in m/s
- $V_{10,C}(N)$: as $V_{Z,C}(N)$ at a height Z = 10 m
- Z : height level referred to still water, in m
- $V_{Z,R}(N)$: N years gust wind velocity at a height Z, in m/s
- $V_{10,R}(N)$: as $V_{Z,R}(N)$, at a height Z = 10 m
- C_H : height coefficient (see Sec 3, [3]).

Formulas for the calculation of wind velocities versus height other than the above are to be previously approved by the Society.

In order to determine the design loads due to the sustained wind velocities, the velocities are generally to be specified by the Interested Parties and are to be not less than the following:

- 36,0 m/s for design loads relevant to the operating environmental conditions;
- 51,5 m/s for design loads relevant to the extreme environmental conditions.

When the unit operating conditions are restricted to sheltered geographical areas, the Society may take into consideration reductions of wind velocity which, for the unit in operating and/or in transit conditions, may in no case be taken less than 25,8 m/s.

2.4.2 Sea waves

a) Foreword

The selection criteria of the design wave is to be specified by the Interested Parties and may be defined by means of design deterministic waves having appropriate shapes, dimensions and periods when the deterministic dynamic analysis is used, or by means of power spectral density functions when the probabilistic dynamic analysis is used.

The parameters describing the design waves are to represent realistically the most unfavourable load conditions anticipated for the unit and are to be based upon reliable wave statistics relevant to operating and transit geographical areas anticipated for the unit considered.

Such parameters are to be deemed acceptable by the Society.

In particular, the description parameters of the design waves is to supply the following information:

- 1) The N years wave height defined as the most probable largest wave height the individual wave may reach with a recurrence period of N years for the anticipated geographical areas;
- 2) The definition of the design wave producing the most unfavourable loads for the unit as a whole and/or on a few or all of its main structural components. The analysis may show that the most unfavourable loads are induced by a wave other than the N years wave previously defined.
- 3) The evaluations of the probability distribution of the waves the unit will meet during its life. Such information is necessary to analyse the fatigue and its effects on the structural components.

b) Deterministic description of the waves

When the deterministic method of sea description is used, the design waves are defined by means of the following parameters:

H, T, λ, h

where:

- H : wave height, i.e. the distance measured vertically between the crest and the trough of the wave, in m;
- T : wave period, in s;
- λ : wave length, in m;
- h : mean sea depth calculated from the still water level, in m

Where necessary, the finite depth effects are to be taken into consideration.

The analysis of wave induced loads on the unit is to be carried out for a few wave periods in order to ensure a sufficiently accurate determination of the maximum loads.

Normally it is sufficient to investigate the following range of wave periods which may turn out to be significant:

$$0,8(H/g)^{0,5} \leq T \leq 20$$

where g is the gravity acceleration, in m/s^2 .

In order to define the design wave height, the smaller of the heights defined as follows is to be selected:

- 1) the N years wave height relevant to the geographical operating and transit areas anticipated for the unit;
- 2) the breaking wave height defined according to the wave periods and to the water depths relevant to the geographical operating and transit areas anticipated for the unit.

As guidance, the curves of the breaking wave height H_F versus the above-mentioned parameters are shown in the diagram in Fig 1.

c) Stochastic description of the waves

When the stochastic method of sea description is used, the waves are analysed taking into account stationary irregular sea states described by the spectral power density functions which are parametrically defined by the significant wave height $H_{1/3}$ and by the average apparent wave period \bar{T} the analytical expressions of the spectral power density functions of the sea states is to reflect the shape and the amplitude of the typical spectra of the significant sea states of the geographical operating and transit areas anticipated for the unit.

The spectral power density function in the Pierson Moskowitz analytic formulation is generally applied for open deep-water sea areas.

In general, a narrower-banded spectrum, e.g. the Jonswap spectrum, is to be used for shallow water.

According to the dynamic analysis methodology, the long term sea behaviour is mathematically described by means of the occurrence probability of each short term spectrum, i.e. by means of a distribution function of the sea states.

In general, the distribution function is used in biparametrical form $(H_{1/3}, \bar{T})$, and is obtained, as a rule, from wave statistics relevant to the geographical areas considered.

2.4.3 Tides

In order to define the design depth, it is necessary to know the values of the sea level increase produced by tides.

The calculation of the depth increase due to tides is necessary for self-elevating units in order to define the crest clearance between the underside of the unit in the elevated position and the crest of the highest wave.

The three following tide components are to be considered to define sea level increase in respect of its mean value:

- astronomical tide;
- barometric tide;
- wind tide.

The astronomical tide is due to the attraction force exerted on the oceans by the moon and the sun.

The barometric tide is due to the low pressure level conditions associated with the local presence of storms.

The values reached by the barometric tides are generally less than those reached by other tide components.

The variation ΔZB , in m, of the water level due to a variation Δp , in N/mm², of the barometric pressure is given by the following equation:

$$\Delta ZB = 102 \Delta p$$

The wind tide is due to the tangential action exerted by wind on the water surface which results in an accumulation of water masses against the coasts.

The values of the wind tide are difficult to calculate and may be obtained, as for the values of astronomical tide, from tables and graphs supplied by recognized meteorologic-oceanographic institutes.

2.4.4 Currents

The current velocity data relevant to the operating areas anticipated for the unit are to be obtained, as far as possible, from reliable statistics.

In order to calculate the design current velocity, all current components which are deemed to be significant are to be taken into account; the main current components are generally the following:

- tide component;
- wind component;
- convection component due to thermal variations.

The design current velocity is given by the vector sum of the individual current components:

$$\vec{V}_{CZ} = \vec{V}_{Cm} + \vec{V}_{Cv} + \vec{V}_{Ct}$$

where:

- \vec{V}_{CZ} : total current velocity, at a distance Z above the sea bottom, in m/s;
- \vec{V}_{Cm} : current component velocity, at a distance Z above the sea bottom, due to tide, in m/s;
- \vec{V}_{Cv} : current component velocity, at a distance Z above the sea bottom, due to wind, in m/s;
- \vec{V}_{Ct} : current component velocity, at a distance Z above the sea bottom, due to thermal variations, in m/s.

When reliable data relevant to current velocity variations versus the distance from the sea bottom are not available, the following equations for

$$\vec{V}_{Cm}$$

and

$$\vec{V}_{Cv}$$

, in m/s, may be used:

$$\vec{V}_{Cm} = \vec{V}_{C1}(Z/h)^{1/7}$$

$$\vec{V}_{Cv} = \vec{V}_{C2}(Z/h)$$

where:

- \vec{V}_{C1} : velocity of the still water surface current due to tide, in m/s;
- \vec{V}_{C2} : velocity of the still water surface current due to wind, in m/s;
- Z : distance from the sea bottom of the point where the current velocity is to be calculated, in m;
- h : distance from the sea bottom of the still water surface, in m.

When reliable statistics are not available to calculate the current velocity

$$\vec{V}_{C2}$$

in open sea areas, the following equation may be used:

$$\vec{V}_{C2} = 0,01 \vec{V}_{10,C}(N)$$

where:

- $\vec{V}_{10,C}(N)$: N years sustained wind velocity, as previously defined, at a height Z = 10 m above the still water level, in m/s.

The current velocity due to tide, to be used in conjunction with the design wave height, shall be not less than 0,5 m/s.

2.4.5 Temperature

The design temperature is to be defined, according to Pt B, Ch 4, Sec 1, [2.5] of the Rules for the Classification of Ships on the basis of the operating and transit geographical areas anticipated for the unit.

Figure 1 : Breaking wave height ($N_{F,NL}$)

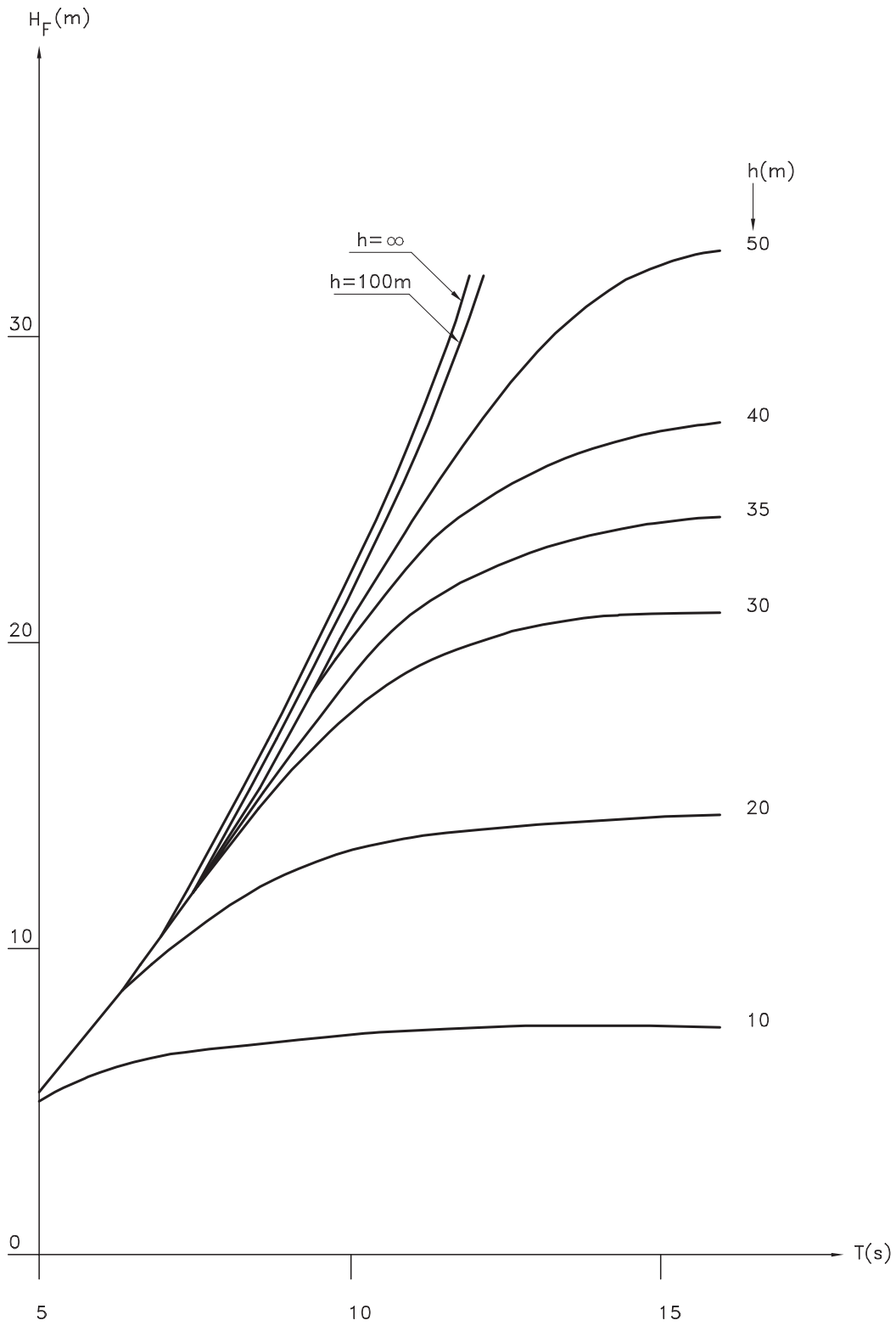

3 Environmental conditions and design loads

3.1 General

3.1.1 The modes of operation for each unit are to be investigated using realistic loading conditions including gravity loadings with relevant environmental loadings.

The following environmental conditions are to be included where applicable:

- a) wind;
- b) wave;
- c) current;
- d) ice;
- e) sea bed conditions;
- f) temperature;
- g) fouling; and
- h) earthquake.

3.1.2 Where possible, the above design environmental conditions are to be based upon significant data with a period of recurrence of at least 50 years for the most severe anticipated environment.

Such recurrence period is to be increased when the Society deems it necessary to adopt more severe environmental conditions.

If a unit is restricted to seasonal operations in order to avoid extremes of wind and wave, such seasonal limitations are also be specified.

3.1.3 Results from relevant model tests may be used to substantiate or amplify calculations.

3.1.4 Limiting design data for each mode of operation are to be stated in the Operating Manual.

3.1.5 Where applicable, the design loads indicated herein are to be adhered to for all types of mobile offshore drilling units. The owner (designer) will specify the environmental conditions for which the unit is to be approved.

3.2 Gravity loads

3.2.1 These loads include:

- the actual weight of the structure including, where applicable, hull, columns, bracing, superstructures, platform and any other significant structural element of the unit;
- the weight of equipment and machinery including all working equipment and appliances, relevant to drilling and any other marine industrial work, such as the derrick or mast, the tube and/or rod stores, the draw-works, the rod-racks, the pumps, the tanks (empty), the fenders, etc.;
- the weight of all the reserves and stores used during industrial work, such as mud, chemical, water, fuel, etc.;
- the weight of water in pipes and tanks during hydrostatic tests;
- the weight of ballast.

3.3 Functional loads

3.3.1 The functional loads include all those loads which occur due to industrial operation of the unit under ideal environmental conditions, i.e. without any environmental loads.

With regard to functional loads acting on decks, a loading plan is to be prepared to the satisfaction of the Society showing the maximum design uniform and concentrated deck loadings for each area for each mode of operation.

Such loading plan is to be included in the Operating Manual.

Design functional loads are to be not less than:

- a) crew spaces, accommodation spaces, walkways, etc.): 4,5 kN/m²
- b) work areas: 9,0 kN/m²
- c) storage areas: 13,0 kN/m²
- d) helideck: 2 kN/m²

Design loads lower than those specified above may be accepted provided that the structures concerned, considered as subjected to the latter loads, do not bear stresses higher than those which are allowed in the case of combined loads.

3.4 Environmental loads

3.4.1 Foreword

All the forces induced on the unit by environmental factors are defined as environmental loads.

The values of the environmental loads may be evaluated either by means of calculations or by means of reliable experimental tests carried out by recognized institutes.

Since environmental factors are of a random nature, their values are to be calculated, in principle, by means of non-deterministic analysis.

The design shall suitably take into account the simultaneous occurrence of different environmental phenomena by superimposing their individual effects.

3.4.2 Wind loading

Sustained and gust wind velocities, as relevant, are to be considered when determining wind loading.

Pressures and resultant forces are to be calculated by the method referred to in Sec 3, [3] or by some other method to the satisfaction of the Society.

Alternatively, wind tunnel data obtained from reliable model tests carried out by recognized laboratories for the evaluation of the wind pressures and forces may be submitted to the Society.

Special attention is to be paid to the design of structures affected by dynamic loads.

Any external surface of closed structures which are not effectively shielded shall be analysed to check the effects of the positive and negative pressure; to this end the following equation may be used:

$$p(Z) = \frac{1}{2} \rho V^2(Z) C_p \cdot 10^{-3} \quad (\text{kN/m}^2)$$

where:

C_p : pressure coefficient, the values of which are as follows:

- $\pm 1,0$, for vertical surfaces;
- $-1,0$, for horizontal surfaces.

The meaning of the other parameters is that given above and in Sec 3, [3].

3.4.3 Wave loading

a) Description of design wave criteria

Design wave criteria are to be described by design wave energy spectra or deterministic design waves having appropriate shape and size.

Consideration is to be given to waves of lesser height, where due to their period, the effects on structural elements may be greater.

b) Evaluation of design wave forces

The wave forces utilized in the design analysis are to include the effects of immersion, heeling and accelerations due to motion.

Such forces are constituted by:

- 1) inertia forces resulting from accelerations of wave water particles and from accelerations due to unit movements;
- 2) drag forces resulting from the boundary layer effects of the sea flow around wetted structures;
- 3) impact forces due to wave slamming against structural members;
- 4) hydrostatic forces resulting from the variations of the wave profile and from the unit movements.

Theories used for the calculation of wave forces and selection of relevant coefficients are to be to the satisfaction of the Society.

The wave forces may affect a structural member both as a single member and as one of a group of similar members; in the latter case the interaction or group effects are present.

When the equivalent diameter of the single structural members is of the same order of magnitude as the distance between the members themselves, the interaction effects (solidification effect, shielding effect and synchronization effect) are to be considered in the calculation of the hydrodynamic forces.

Such effects are more pronounced, the nearer the members are to each other and to the free surface of the water.

- Inertia forces

Different methods may be used to calculate the inertia forces.

In particular, the Morison method may be used on the assumption that the equivalent diameter of the member considered would not significantly deform the incident wave, i.e. on the assumption that the ratio of the member equivalent diameter to the wave length is very small.

A more suitable theory, e.g. the potential theory, is generally to be used for bodies with equivalent diameter which is not negligible compared to wave length; in general, for such bodies, the inertia forces

are preponderant with respect to drag forces, which may therefore be disregarded.

For cylindrical elements, both ends of which are not free (i.e. with the characteristic that only the cylindrical surface is subject to wave action) and having arbitrary cross-sectional shape, the following Morison equation for the inertia force vector \vec{F}_i , in kN, is generally accepted:

$$\vec{F}_i = \rho \cdot A \cdot \Delta l \cdot [(1 + C_m) \cdot \vec{u} \wedge \vec{a}_w \wedge \vec{u} + C_m \cdot \vec{u} \wedge \vec{a}_e \wedge \vec{u}] \cdot 10^{-3}$$

where:

- ρ : specific mass of water, in kg/m³;
- A : cross-sectional area of the structural element considered, in m²;
- Δl : length of the axis of the structural element considered, in m;
- C_m : added mass coefficient depending upon the shape of the cylindrical element considered;
- \vec{u} : unit vector of the cylindrical element axis;
- \vec{a}_w : water particles acceleration vector due to the waves, in m/s²;
- \vec{a}_e : structural element acceleration due to the movement of the unit on the waves, in m/s²;

For a practically isolated structural element (i.e. with equivalent diameter preponderant with respect to the bracing equivalent diameter), the following Morison equation for the inertia force vector \vec{F}_i in kN, is generally accepted:

$$\vec{F}_i = \rho \cdot V \cdot [(1 + C_m) \cdot \vec{u} \wedge \vec{a}_w \wedge \vec{u} + C_m \cdot \vec{u} \wedge \vec{a}_e \wedge \vec{u}] \cdot 10^{-3}$$

where:

- V : volume of the structural element considered, in m³.

The other symbols are as defined above.

- Drag forces

Different methods may be used to evaluate the drag forces.

In particular the Morison method may be used on the same assumption specified above for inertia forces.

For cylindrical elements, both ends of which are not free (i.e. with the characteristic that only the cylindrical surface is subject to wave action) and having arbitrary cross-sectional shape, the following Morison equation for the drag force vector \vec{F}_D , in kN, is generally accepted:

$$\vec{F}_D = \frac{1}{2} \rho \cdot D \cdot \Delta l \cdot C_D \cdot v \cdot \vec{u} \wedge \vec{v} \wedge \vec{u} \cdot 10^{-3}$$

where:

- D : cross-section dimension of the cylindrical element considered normally to the plane defined by the axis of the element and the vector \vec{v} , in m;
- Δl : length of the structural element, in m;
- C_D : drag coefficient;
- v : modulus of vector \vec{v} , in m/s
- \vec{v} : relative velocity vector of the water particles with respect to the element;
- \vec{u} : unit vector of the cylindrical element axis.

The vector \vec{v} results from the following equation:

$$\vec{v} = \vec{v}_w - \vec{v}_e - \vec{v}_u$$

where:

- \vec{v}_w : orbital velocity vector of water particles due to waves;
- \vec{v}_e : velocity vector of the structural element due to the motion of the unit on the waves;
- \vec{v}_u : advancing velocity vector of the unit.

For a practically isolated structural element (i.e. with equivalent diameter preponderant with respect to the equivalent diameter of the bracings), the drag force may generally be disregarded when compared to the inertia force.

When the drag force is significant, the following Morison equation is generally applied:

$$\vec{F}_D = \frac{1}{2} \rho \cdot A \cdot C_D \cdot v \cdot \vec{u} \wedge \vec{v} \wedge \vec{u} \cdot 10^{-3}$$

where:

- A : cross-sectional area of the structural element considered, in m².

- Impact forces

Impact forces from waves against the structures shall be determined according to recognized theoretical methods or from results of model tests.

Possible dynamic amplification of such forces shall be carefully considered.

In App 1 a method for calculating such forces is described.

- Wave induced vibrations

Consideration should be given to the possibility of wave induced vibrations.

3.4.4 Current loadings

The current induced forces acting on immersed members are drag forces.

The following Morison equations may be considered to calculate the forces due to current on the same assumption specified above for drag forces due to waves:

- for structural cylindrical elements both ends of which are not free, whatever their cross section is:

$$\vec{F}_{DC} = \frac{1}{2} \rho \cdot D \cdot \Delta l \cdot v_c \cdot \vec{u} \wedge \vec{v}_c \wedge \vec{u} \cdot 10^{-3}$$

- for cylindrical structural elements which are practically isolated:

$$\vec{F}_{DC} = \frac{1}{2} \rho \cdot A \cdot C_D \cdot v_c \cdot \vec{u} \wedge \vec{v}_c \wedge \vec{u} \cdot 10^{-3}$$

where:

- \vec{F}_{DC} : drag force vector due to current, in kN;
- v_c : modulus of vector \vec{v}_c in m/s;
- \vec{v}_c : current velocity vector for the location in which the unit rests.

The other symbols are as defined above.

Consideration is to be given to the interaction of current and waves. Where necessary, the effects are to be superimposed by adding the constant current velocity \vec{v}_c vectorially to the orbital wave particle velocity. The resultant velocity should be used in calculating the structural loading due to current and waves.

3.4.5 Loading due to vortex shedding

Consideration is to be given to loading induced in structural members due to vortex shedding.

The von Karman vortices may occur downstream from the cylindrical structural elements, whatever their cross section is, when the flow around them and normally to their axis reaches critical velocities.

In app 1 a method for the determination of hydrodynamic forces induced by vortex shedding is described.

3.4.6 Loading due to ice

The following forces due to ice are to be considered, when relevant, for units designed for operations in geographic areas where the design temperature is less than 0°C:

- static forces due to ice accumulation on superstructures and decks;
- impact forces due to ice masses falling on structures;
- impact forces due to the impact of the unit against icebergs;
- forces exerted on the structures by the freezing of sea sprays;
- forces exerted on the wind exposed structures caused by the increase of the areas of wind exposed surfaces due to ice.

For the definition of design temperature, see [2.4.5].

3.5 Additional loads

3.5.1 Foreword

All loads that are not covered by the definition of gravity, functional or environmental loads are defined as additional loads.

The main additional loads are the following:

- loads arising from maintaining the unit on station;
- loads arising from towing operations;
- loads arising from boarding;
- loads arising from building and positioning operations.

3.5.2 Additional loads arising from maintaining the unit on station

The additional loads due to systems and equipment fitted to maintain the unit on station are to be considered according to the two following structural aspects:

- a) loads relevant to the overall strength of the unit structure;
- b) loads relevant to the local strength of the structure where the maintaining on station forces are transmitted to the unit.

For calculation of the above-mentioned loads, the forces due to waves, wind and current, are to be taken into account in addition to the pretension force of the mooring lines.

For calculation of the above loads, due account is to be taken of all mooring configurations and of all associated environmental conditions indicated in the Operating Manual.

When, for calculation of the overall strength of the unit, the motion of the latter due to waves is evaluated, the horizontal force components of the mooring lines are to be considered taking into account, in the motion equations, the adequate elastic constants of the mooring lines.

Of the six degrees of freedom movements of the unit, the mooring line tensions may only be significantly modified by the following horizontal movements:

- surge
- sway
- yaw

while the variation of the mooring line tensions due to the following movements:

- heave
- roll
- pitch

may be disregarded.

When the quasi-static analysis (see [1.2.2]) is used for the calculation of the overall strength of the unit, the horizontal force components of the mooring lines are to be considered equal and opposite to the forces arising from wind and current.

The loads induced on the structures by the dynamic positioning systems shall be considered when relevant.

3.5.3 Additional loads arising from towing operations

The additional loads arising from towing operations are applicable to the unit while it is being towed by tugs; they may be subdivided into the following forces:

- a) static forces applied to the unit-tug connections; these depend on the velocity of the unit transit motions on water (resulting from the unit transit velocity and from the current velocity, both measured with respect to the seabed) and on the wind velocity;
- b) dynamic forces applied to the unit-tug connections; these arise from the unit-tug relative movement caused by the wave action.

3.5.4 Additional loads arising from building and positioning operations

These loads applied to the unit structures occur during the construction and positioning operations.

The following stages of such operations may give rise to considerable stresses:

- assembling
- launching
- drydocking
- immersion
- emersion
- raising and lowering of self-elevating units or of any other type of articulated unit, etc.

3.5.5 Additional loads arising from boarding

The loads arising from boarding are impulsive and are due to the relative movements of the unit and vessels alongside.

The following equation for the evaluation of the maximum value of the boarding force is given for guidance:

$$F_{abb} = \left(2,5 \frac{H}{gT^2} + 0,05 \right) P$$

where:

- F_{abb} : boarding force, in kN;
- H : maximum wave height for which the possibility of boarding is accepted, in m;
- T : period of the above-mentioned wave, in s;
- P : maximum anticipated weight for the vessel whose boarding force is to be evaluated, in kN;
- g : gravity acceleration, in m/s^2 .

When a spectral definition of the sea states is used, H and T are, respectively, the significant wave height and mean apparent period values of the state in which boarding is expected to occur.

4 Structural analysis

4.1

4.1.1 Sufficient loading conditions for all modes of operation are to be analysed to enable the critical design cases for all principal structural components to be evaluated.

This design analysis should be to the satisfaction of the Society.

Calculations for relevant conditions are to be submitted to the Society for consideration.

The analysis is to be performed using an appropriate calculation method and are to be fully documented with references.

The Society may, at its discretion, require the application of design loads other than those mentioned above when this is called for by the particular type, structure or use of the unit.

For each considered loading condition, relevant to the associated operational condition, the following primary stresses

shall be determined for comparison with the appropriate allowable stresses given in 5.

- a) stresses due to static loading only, in calm water conditions, where the "static loads" include functional loads and gravity loads acting on the structures, with the unit afloat or resting on the sea-bed, as applicable;
- b) stresses due to combined loading, where the applicable static loads in a) are combined with significant design environmental loads, including acceleration and heeling forces.

4.1.2 The scantlings are to be determined on the basis of criteria which combine, in a rational manner, the individual stress components in each structural element.

Such criteria are to be acceptable to the Society.

The allowable stresses are to be to the satisfaction of the Society.

4.1.3 Local stresses, including stresses caused by circumferential loadings on tubular members, are to be added to primary stresses in evaluating combined stress levels.

4.1.4 For calculation of bending stresses, the effective flange areas are to be determined in accordance with effective width concepts acceptable to the Society.

Elastic deflections are to be taken into account, as appropriate, when determining the effects of eccentricity of axial loading, and the resulting bending moments are to be superimposed on the bending moments calculated for other types of loading.

4.1.5 For calculation of shear stresses in bulkheads, plate girder webs or hull side plating, only the effective shear area of the web are to be considered.

In this regard, the total depth of the girder may be considered as the web depth.

4.1.6 For structural components analysed within the linear elastic field, the equivalent stresses calculated according to von Mises' criterion may not exceed the permissible stresses given in [5].

Criteria other than the von Mises' criterion used in the evaluation of equivalent stresses are to be submitted to the Society for approval.

4.1.7 Members of grillage type structures are to be designed in accordance with recognized calculation methods for such structures.

4.1.8 The buckling strength of structural members is to be evaluated where appropriate.

The buckling analysis of the structures is to be carried out using generally accepted theories.

Buckling analysis criteria other than those commonly used are subject to approval by the Society.

For structures subject to buckling, the effect of the predeformations due to geometrical and construction imperfections shall, if possible, be taken into account for the determination of the critical buckling stresses.

In the case of structural members analysed as beams, the critical buckling stress may be determined as follows:

$$\sigma_{cr} = \left[1 - \frac{1}{2} \left(\frac{\lambda}{\lambda_0} \right)^2 \right] \sigma_s \quad \text{if } \lambda < \lambda_0$$

$$\sigma_{cr} = \frac{1}{2} \left(\frac{\lambda_0}{\lambda} \right)^2 \sigma_s \quad \text{if } \lambda \geq \lambda_0$$

where:

σ_s : yield strength of the material;

$$\lambda = \frac{Kl}{r}$$

$$\lambda_0 = \left(\frac{2\pi^2 E}{\sigma_s} \right)^{0.5}$$

Kl : effective unsupported length;

r : governing (minimum) radius of gyration associated with Kl ;

E : modulus of elasticity of material.

When the beam concerned is made of compound members or is subject to local buckling, the critical buckling stress are to be suitably reduced.

When structural members under compression are subjected to combined stress condition, possible second order effects are to be taken into account.

In particular, in the case of beams subjected to combined compression and bending, the bending stress are to be multiplied by the amplifying coefficient equal to:

$$\frac{1}{1 - \frac{\sigma_c}{\sigma_{cr}}}$$

where σ_c is the stress due to compression only.

Structural members subjected to torsional buckling in loading conditions lower than those which may produce lateral buckling are to be checked for torsional buckling.

Stiffeners are to be analysed in such a way that the stiffened plate has a total buckling load higher than the local buckling load of single panels between the stiffeners.

Unstiffened or ring stiffened cylindrical structures with circular cross section subjected to axial compression, or compression due to bending, or a combination thereof, and having proportions which satisfy the following relationship:

$$\frac{D}{t} < \frac{E}{9\sigma_s}$$

where:

D : cylinder mean diameter

t : cylinder wall thickness

need not be checked for local buckling.

Designs based on novel or unconventional methods such as plastic analysis or elastic buckling concepts will be specially considered by the Society.

4.1.9 Where deemed necessary by the Society, a fatigue analysis based on intended operating areas or environments is to be provided.

The fatigue analysis of the structural elements is to be based upon a period of time not less than the anticipated unit life, normally not less than 20 years.

The detailed fatigue analysis is generally carried out on particularly critical structures, e.g. on joints.

The fatigue analysis criteria used in the unit design is subject to acceptance by the Society.

When the fatigue analysis is performed with the cumulative damage method, as mentioned in App 2, the allowable limits of the cumulative damage will be subject to special consideration by the Society.

The equivalent stresses used in the fatigue analysis are to take into account stress concentration and the effect that cyclical loads may have on corrosion.

4.1.10 The effect of notches, local stress concentrations and other stress raisers should be allowed for in the design of primary structural elements.

4.1.11 Where possible, structural joints are to not designed so that they do not transmit primary tensile stresses through the thickness of plates integral with the joint.

Where such joints are unavoidable, the plate material properties and inspection procedures selected to prevent lamellar tearing are to be to the satisfaction of the Society.

4.1.12 In addition to the above, the unit structures are to be investigated with respect to the following effects, when appropriate:

- brittle fracture;
- excessive deformation;
- loss of water-tightness;
- excessive vibrations.

The most unfavourable stresses for a unit may be associated with conditions less severe than the extreme design environmental conditions specified by the Designer.

In this case the Society may require such additional environmental conditions to be considered taking account of one or both of the following precautions:

- a) appropriate reduction of the allowable stresses associated with the case of combined loads;
- b) careful investigation of the fatigue behaviour of the structures concerned.

5 Safety factors and permissible stresses

5.1

5.1.1 The safety factors indicated in Tab 1 are to be considered in the structural analysis of all the members of the platform in relation to the possible types of collapse.

Where, for a structural member under compression, the critical buckling load P_{cr} is higher than the proportional load P_p , the safety factor for buckling may be assumed equal to:

$$\frac{1,5}{1 - 0,13(P_p/P_{cr})^{0,5}}$$

P_p being the extreme load between the elastic and the inelastic buckling [4.1.8] apply, is to be assumed to be equal to half the yield stress.

Table 1

Type of collapse	Safety factor
yielding	1,5
failure	1,725
buckling	1,725

5.1.2 In the case of structural members analysed as beams, the stresses calculated for the single types of stress are not to exceed the following values:

- tensile: $0,6 \sigma_s$
- shear: $0,4 \sigma_s$
- bending: $0,6 \sigma_s$
- compression:

$$\sigma_a = 0,6 \left(1 - 0,13 \frac{\lambda}{\lambda_o} \right) \sigma_{cr} \quad \text{if } \lambda < \lambda_o$$

$$\sigma_a = 0,522 \cdot \sigma_{cr} \quad \text{if } \lambda \geq \lambda_o$$

- tensile and bending:

$$\frac{\sigma_t}{0,6 \cdot \sigma_s} + \frac{\sigma_f}{0,6 \cdot \sigma_s} \leq 1,0$$

- compression and bending:

$$\frac{\sigma_c}{\sigma_a} + \frac{\sigma_f}{0,6 \cdot \sigma_s} \leq 1,0$$

where:

- σ_t : tensile stress;
- σ_c : compressive stress;
- σ_f : maximum stress due to bending, which shall be multiplied, in the case of members subject to compression and bending, by the amplifying coefficient given in [4.1.8];
- σ_{cr} : critical buckling stress (see [4.1.8]).

Where the beam concerned is subject to local buckling, the permissible bending stresses shall be suitably reduced.

5.1.3 Where they are referred to combined stresses (see [4.1.1]), the values of the safety factors given in [5.1.1] may be reduced by 1/4 and the permissible stresses given in [5.1.2] may be increased by 1/3.

Note 1: The allowable stresses as stated above are intended to reflect uncertainties in environmental data, determination of loadings from the data and calculation of stresses.

It is understood that the adoption of separate load factors or safety factors for the above influences may be allowed, and that allowance can be given for improvements in environmental condition forecasting, load estimation or structural analysis, as the technology or expertise in any one of these areas improves.

6 Special design principles applied to surface units

6.1 Hull

6.1.1 The longitudinal strength of the unit required by the Rules is to be maintained in way of the drilling well, and particular attention is to be given to the transition of fore and aft members, so as to maintain the continuity of the longitudinal material.

The plating of the well is to be suitably stiffened to prevent damage when the unit is in transit.

6.1.2 Consideration should be given by means of suitable compensation to the scantlings necessary to maintain strength in way of large hatches.

6.1.3 The structure in way of heavy concentrated loads, such as those resulting from the drilling derrick, tube store or rack, drilling mud storage, draw-works, etc., is to be suitably reinforced.

6.1.4 The structure in way of components for the position mooring system such as fairleads and winches is to be designed to withstand the stresses imposed when a mooring line is loaded to its breaking strength.

7 Special design principles applied to self-elevating units

7.1 Hull

7.1.1 The hull strength is to be evaluated in the elevated position for the specified environmental conditions with maximum gravity loads aboard and supported by all legs.

The distribution of these loads in the hull structure is to be determined by a method of rational analysis.

Scantlings are to be calculated on the basis of this analysis, but should not be less than those required for other modes of operation.

7.1.2 Scantlings of units having other than rectangular hull configurations are subject to special consideration.

7.2 Wave clearance

7.2.1 The unit is to be so designed as to enable the hull to clear the highest design wave including the combined effects of astronomical and storm tides.

The minimum clearance may be the lesser of either:

- 1,2 m; or
- 10% of the combined astronomical tide, storm tide and height of the design wave above the mean low water level.

In any case, the above clearance is not to be less than 0,5 m, unless the unit operation is restricted to harbour waters or sheltered areas.

7.2.2 The effects due to the lowering of the unit caused by the legs' subsidence into the sea-bed are to be taken into account whenever significant.

7.2.3 A clearance less than that specified above may be considered whenever the lower structures of the hull which are expected to come into contact with waves are designed taking account of impulsive wave loads.

7.3 Legs

7.3.1 Legs may be either shell type or truss type.

Shell type legs may be designed as either stiffened or unstiffened shells.

In addition, individual footings may be fitted or legs may be permanently attached to a bottom mat.

7.3.2 Where footings or mats are not fitted, proper consideration should be given to the penetration of the sea bed and the consequent end fixity of the leg.

7.3.3 Legs are to be designed to withstand the dynamic loads which may be encountered by their unsupported length while being lowered to the bottom, and also to withstand the shock of bottom contact due to wave action on the hull.

The maximum design motions, sea state and bottom conditions for operations to raise or lower the hull should be clearly stated in the Operating Manual.

The legs are not permitted to touch the sea-bed when the site conditions are other than those allowed.

7.3.4 When evaluating leg stresses with the unit in the elevated position, the maximum overturning moment on the unit due to the most adverse combination of applicable environmental and gravity loadings should be considered.

7.3.5 For the field transit condition, the following requirements apply.

Legs are to be designed for the most severe environmental transit conditions anticipated including wind moments, gravity moments and accelerations resulting from unit motions.

The Society is to be provided with calculations, an analysis based on model tests, or a combination of both.

As an alternative, legs may be designed for a bending moment caused by minimum design criteria of a single cycle of roll or pitch of suitable amplitude and period, plus 120% of the bending moment caused by gravity and the legs' angle of inclination.

Values of amplitude and period of such cycle are to be approved by the Society.

Amplitudes less than 6° and periods greater than the natural period of the unit shall generally not be accepted.

The legs are to be investigated for any proposed leg arrangement with respect to vertical position during field transit moves, and the approved positions are to be specified in the Operating Manual.

Such investigation is to include strength and stability aspects.

7.3.6 For the ocean transit condition, the following requirements apply.

Legs are to be designed for the most severe environmental transit conditions anticipated including wind moments,

gravity moments and accelerations resulting from unit motions.

The Society is to be provided with calculations, an analysis based on model tests, or a combination of both.

Alternatively, legs may be designed for a bending moment caused by a single cycle of roll or pitch of suitable amplitude and period, plus 120% of the bending moment caused by gravity and the legs' angle of inclination.

Values of amplitude and period of such cycle are to be approved by the Society.

Amplitudes less than 15° and periods greater than 10 s may generally not be accepted.

Acceptable oceanic transit conditions are to be included in the Operating Manual.

For some transit conditions, it may be necessary to reinforce or support the legs, or to remove sections to ensure their structural integrity.

Where the oceanic transit is effected on board special craft, dynamic loads on the unit are subject to special consideration by the Society.

7.3.7 Leg scantlings are to be determined in accordance with a method of rational analysis, to the satisfaction of the Society.

7.3.8 In the case of significant leg penetration into the seabed it may be necessary to apply large forces to the legs in order to draw them.

Such forces shall be taken into account in designing legs and connecting structures to hull. The maximum allowed values are to be specified in the Operating Manual.

7.4 Pre-loading capability of legs

7.4.1 Except for those units utilizing a bottom mat, the capability is to be provided to pre-load each leg to the maximum applicable combined load after initial positioning at a site.

The pre-loading procedures are to be submitted to the Society for approval and included in the Operating Manual.

7.5 Structures connecting legs to hull

7.5.1 Structural members which transmit loads between the legs and the hull are to be designed for the maximum loads transmitted and arranged to diffuse the loads into the hull structure.

7.6 Bottom mat

7.6.1 When a mat is utilized to transmit the bottom bearing loads, attention are to be given to the attachment of the legs so that the loads are diffused into the mat.

7.6.2 Where tanks in the mat are not open to the sea, the scantlings are to be based on a design head using the maximum water depth and tidal effects.

7.6.3 Mats are to be designed to withstand the loads encountered during lowering including the shock of bottom contact due to wave action on the hull.

7.6.4 The effect of possible scouring action (loss of bottom support) are to be considered.

The effect of skirt plates, where provided, is to be given special consideration.

7.7 Sea-bed conditions

7.7.1 Classification is to be based upon the designer's assumptions regarding the sea-bed conditions.

These assumptions are to be specified in the Operating Manual.

It is the responsibility of the operator to ensure that actual conditions do not impose more severe loadings on the unit.

7.8 Deckhouses

7.8.1 Deckhouses located near the side shell of a unit are to be those required by the Rules for an unprotected house front.

Other deckhouses, i.e. those located in positions protected by other deckhouses, are to have scantlings suitable for their size, function and location, based on the requirements of the Rules.

8 Special design principles applied to column stabilized units

8.1 General

8.1.1 For units of this type, the highest stresses may be associated with less severe environmental conditions than the maximum specified by the designer or by the owner.

Where considered necessary by the Society, account is to be taken of the consequent increased possibility of occurrence of significant stress levels, by either or both of the following:

- a) suitable reduction of the allowable stress levels for combined loadings (see [5]);
- b) detailed investigation of the fatigue behaviour.

Particular attention is to be given to the details of structural design in critical areas such as bracing members, joint connections, etc.

8.2 Wave clearance of upper deck

8.2.1 Unless deck structures are designed for wave impact, a clearance acceptable to the Society, taking account of anticipated unit movements, is to be maintained between passing wave crests and the deck structure.

The Society is to be provided with model test data, reports on past operating experience with similar configurations or calculations showing that adequate provision is made to maintain this clearance.

8.2.2 For units operating while supported by the sea bed the clearance required in [7.2] are to be maintained.

8.3 Upper deck

8.3.1 The scantlings of the upper structure are not to be less than those required by Part B, considering the upper deck as the strength deck of a unit, for the loading shown in the deck loading plan.

These loadings are to be not less than the minima specified in [3.3].

In addition, when the upper deck structure is considered to be an effective member of the overall structural frame of the unit, the scantlings are to be sufficient to withstand actual local loadings plus any additional loadings superimposed by the primary structures of the unit, within the stress limitations given in [5].

8.3.2 When an approved mode of operation or damage condition in accordance with the stability requirements allows the upper structure to become waterborne, special consideration is to be given to the resulting structural loading.

8.4 Columns, lower hulls and footings

8.4.1 The scantlings of columns, lower hulls and footings are to be based on the evaluation of hydrostatic pressure loading and combined loading including wave and current considerations.

8.4.2 Main stability columns, lower hulls or footings may be designed as either framed or unframed shells.

In either case, framing, ring stiffeners, bulkheads or other suitable diaphragms which are used are to be sufficient to maintain shape and stiffness under all the anticipated loadings.

8.4.3 Where columns, lower hulls or footings are designed with stiffened plating, the minimum scantlings of plating, framing, girders, etc. may be determined in accordance with the requirements for tanks.

The design head to be used for subdivision bulkheads is that corresponding to the final waterline of the unit in damaged condition.

The scantlings of shell plates and associated stiffeners of columns, lower hulls and footings are to be calculated either as above for subdivision bulkheads, or as tank bulkheads with a head corresponding to the maximum allowable waterline for intact condition, adopting the more severe scantling. The stiffeners of external shells of columns and of the upper hull are also to be verified as side or superstructure stiffeners, as appropriate.

In addition, the scantlings of bulkheads bounding a tank are to be calculated as for tank bulkheads with internal head.

8.4.4 Where columns, lower hulls or footings are designed as shells, either unstiffened or ring stiffened, the minimum scantlings of shell plating and ring stiffeners are to be determined on the basis of established shell analysis using the appropriate safety factors and the design heads as given in [8.4.3].

8.4.5 Scantlings of columns, lower hulls or footings as determined in [8.4.3] and [8.4.4] are minimum requirements for hydrostatic pressure loads.

Where wave and current forces are superimposed, the local structure of the shell is to be increased in scantlings as necessary to meet the strength requirements of [2.4].

8.4.6 Where a column, lower hull or footing is a part of the overall structural frame of a unit, consideration is also to be given to stresses resulting from deflections due to the applicable combined loading.

8.4.7 Particular consideration is to be given to structural arrangements and details in areas subject to high local loading resulting from, for example, external damage (collisions, grounding, etc.), wave impact, partially filled tanks, bottom bearing operations or continuity through joints.

8.4.8 When a unit is designed for operations while supported by the sea-bed, the footings are to be designed to withstand the shock of bottom contact due to wave action on the hull.

Such units are also to be evaluated for the effects of possible scouring action (loss of bottom support).

As a first approach the scouring effects may be evaluated as follows:

- for units designed to rest on a single large footing, a non-bearing area equal to 20% of the area covered by the footing is considered;
- when two or more footings are provided, the area of each footing resting on the sea-bed shall be considered not greater than 50% of its bearing surface.

The non-bearing areas are to be located in the most severe positions for unit safety.

The effect of skirt plates, or any other arrangement to prevent loss of sea-bed bearing capacity, are to be given special consideration.

8.4.9 The structure in way of components of the position mooring system such as fairleads and winches is to be designed to withstand the stresses imposed when a mooring line is loaded to its breaking strength.

8.5 Bracing members

8.5.1 Bracing members are to be designed to make the structure effective against applicable combined loading, and when the unit is supported by the sea-bed, against the possibility of uneven bottom bearing loading.

Bracing members are to be capable to withstand, where applicable, the combined stresses including local bending stresses due to buoyancy, wave forces and current forces.

8.5.2 Where applicable special consideration is to be given to local stresses caused by wave impact.

8.5.3 Where bracings are watertight they are to be designed to prevent collapse from hydrostatic pressure.

Underwater bracing are normally to be made watertight and have a leak detection system to make it possible to detect fatigue cracks at an early stage.

8.5.4 Consideration is to be given to the need for ring frames to maintain stiffness and shape in tubular bracing members.

8.6 Structural redundancy

8.6.1 The unit's structure is to be able to withstand the loss of any slender bracing member without causing overall collapse when exposed to environmental loading corresponding to a one-year return period for the intended area of operation.

Structural redundancy is to be based on the applicable requirements of [3], [4], [5] and [1.2.2]. Maximum calculated stresses in the structure remaining after the loss of a slender bracing member are to be in accordance with [5] in association with safety factors not less than 1,0 and permissible stresses not greater than yielding or buckling stresses.

This criteria may be exceeded for local areas, provided redistribution of forces due to yielding or buckling is taken into consideration.

8.6.2 The structural arrangement of the upper hull is to be considered with regard to the structural integrity of the unit after the assumed failure of any primary girder. The Society may require a structural analysis showing satisfactory protection against overall collapse of the unit after such an assumed failure when exposed to environmental loading corresponding to a one-year return period for the intended area of operation.

8.7 Fatigue analysis

8.7.1 The possibility of fatigue damage due to cyclic loading is to be considered in the design of self-elevating and column-stabilized units.

The fatigue analysis is to be based on the intended mode and area of operations to be considered in the unit's design.

The fatigue analysis is to take into account the intended design life and the accessibility of individual structural members for inspection.

SECTION 3

STABILITY

1 General

1.1 Application

1.1.1 Requirements contained in this Section are additional to those contained in Part B, Chapter 3, except for Item [2] that is to be applied in lieu of Pt B, Ch 3, Sec 1, [2.2].

1.1.2 All units are to have positive stability in calm water equilibrium position, for the full range of draughts when in all modes of operation afloat, and for temporary positions when raising or lowering.

In addition, all units are to meet the stability requirements set forth below for all applicable conditions.

1.2 Document to be submitted

1.2.1 The stability documentation to be submitted for approval is as follows:

- damage stability calculations,
- damage control documentation.

1.2.2 A copy of the documentation as per [1.2.1] is to be available on board for the attention of the Master.

2 Inclining test

2.1

2.1.1 An inclining test is to be required for the first unit of a design, when the unit is as near to completion as possible, to determine accurately the light ship data (weight and position of centre of gravity).

The test procedure is to be submitted to the Society for approval prior to the test.

2.1.2 For successive units which are identical by design, the light ship data of the first unit of the series may be accepted by the Society in lieu of an inclining test, provided the difference in light ship displacement or position of centre of gravity due to weight changes for minor differences in machinery, outfitting or equipment, confirmed by the results of a deadweight survey, is less than 1% of the values of the light ship displacement and principal horizontal dimensions as determined for the first of the series. Extra care is to be given to the detailed weight calculation and comparison with the original unit of a series of column-stabilized, semi-submersible types as these, even though identical by design, are recognized as being unlikely to attain an acceptable similarity of weight or centre of gravity to warrant a waiver of the inclining test.

2.1.3 The results of the inclining test, or deadweight survey and inclining experiment adjusted for weight differences, are to be indicated in the Operating Manual.

2.1.4 A record of all changes to machinery, structure, outfitting and equipment that affect the light ship data, is to be maintained in the Operating Manual or in a light ship data alterations log and be taken into account in daily operations.

2.1.5 For column-stabilized units, a deadweight survey is to be conducted at intervals not exceeding 5 years. Where the deadweight survey indicates a change from the calculated light ship displacement in excess of 1% of the operating displacement, an inclining test is to be conducted.

2.1.6 The inclining test or deadweight survey is to be attended by a Surveyor of the Society. The Society may accept inclining tests or lightweight checks attended by a member of the flag Administration.

2.1.7 For units which have undergone work of minor importance and for which the weights and the centres of gravity of shipped and unshipped loads are known, the new displacement and centre of gravity obtained from calculation carried out on the basis of the original data are deemed satisfactory.

3 Righting moment and heeling moment curves

3.1

3.1.1

Righting moment curves and wind heeling moment curves related to the most critical axis, with supporting calculations, are to be prepared for a sufficient number of conditions covering the full range of draughts corresponding to afloat modes of operation (see Fig. 1). Where drilling equipment is of the nature that it can be lowered and stowed, additional wind heeling moment and stability curves may be required, and such data should clearly indicate the position of such equipment. In all cases, except column stabilized units, the area under the righting moment curve to the second intercept or downflooding angle, whichever is less, is not to be less than 40% in excess of the area under the wind heeling moment curve to the same limiting angle. For column stabilized units, the area under the righting moment curve to the angle of downflooding is not to be less than 30% in excess of the area under the wind heeling moment curve to the same limiting angle. In all cases, the righting moment curve is to be positive over the entire range of angles from upright to the second intercept.

3.1.2

a) The curves of wind heeling moments are to be drawn for wind forces calculated by the following formula:

$$F = 0,5 C_s \cdot C_H \cdot r \cdot V^2 \cdot A$$

where:

- F : the wind force, in N
- C_s : the shape coefficient depending on the shape of the structural member exposed to the wind (see Tab 1);
- C_H : the height coefficient depending on the height above sea level of the structural member exposed to wind (see Tab 2);
- r : the air mass density (1,222 kg/m³)
- V : the wind velocity, in m/s;
- A : the projected area of all exposed surfaces in either the upright or the heeled condition, in m²

Shapes or combinations of shapes which do not readily fall into the specified categories will be subject to special consideration by the Society.

b) Wind forces should be considered in any direction relative to the unit realistic operating conditions are to be evaluated as follows:

- 1) The unit is to be capable of remaining in the operating mode with a sustained wind velocity of not less than 36 m/s (70 knots).
- 2) The capability is to be provided to change the mode of operation of the unit to that corresponding to a severe storm condition, with a sustained wind velocity of not less than 51,5 m/s (100 knots), in a reasonable period of time for the particular unit.
- 3) In all cases, the limiting wind velocities are to be specified and instructions are to be included in the Operating Booklet for changing the mode of operation by redistribution of the variable load and equipment, by changing draughts, or both.
- 4) For restricted operations consideration may be given to a reduced sustained wind velocity of not less than 25,8 m/s (50 knots). Particulars of the applicable service restrictions are to be recorded in the Operating Booklet. For the purpose of calculation it is to be assumed that the unit is floating free of mooring restraints.

c) In calculating the projected areas to the vertical plane, the area of surfaces exposed to wind due to heel or trim, such as under-deck surfaces, etc., is to be included using the appropriate shape factor. Open truss work may be approximated by taking 30% of the projected block area of both the front and back section, i.e. 60% of the projected block area of one side.

An appropriate shape coefficient is to be taken from Tab 1.

Table 1 : Values of the shape coefficient C_s

Shape	C _s
Spherical	0,4
Cylindrical	0,5
Large flat surfaces (hull, deckhouse, smooth under-deck areas)	1,0
Drilling derrick	1,25
Wires	1,2
Exposed beams and girders under deck	1,3
Small parts	1,4
Isolated shapes (crane, beam, etc.)	1,5
Clustered deckhouses or similar structures	1,1

Table 2 : Values of the height coefficient C_H

Height above sea level (m)	C _H
0 - 15,3	1,00
15,3 - 30,5	1,10
30,5 - 46,0	1,20
46,0 - 61,0	1,30
61,0 - 76,0	1,37
76,0 - 91,5	1,43
91,5 - 106,5	1,48
106,5 - 122,0	1,52
122,0 - 137,0	1,56
137,0 - 152,5	1,60
152,5 - 167,5	1,63
167,5 - 183,0	1,67
183,0 - 198,0	1,70
198,0 - 213,5	1,72
213,5 - 228,5	1,75
228,5 - 244,0	1,77
244,0 - 256,0	1,79
above 256	1,80

d) In calculating the wind forces, the following procedures are recommended:

- 1) in the case of units with columns, the projected areas of all columns are to be included; i.e. no shielding allowance is to be taken;
- 2) the block projected area of a clustering of deckhouses may be used in lieu of the calculation of each individual area. The shape coefficient may be assumed to be 1,1;

- 3) isolated houses, structural shapes, cranes, etc. are to be calculated individually, using the appropriate shape coefficient.

3.1.3 In calculating the wind heeling moments, the lever of the wind overturning force is to be taken vertically from the centre of pressure of all surfaces exposed to the wind to the centre of lateral resistance or, if available, the centre of hydrodynamic pressure, of the underwater body of the unit. The unit is to be assumed floating free of mooring restraint. However, the possible detrimental effects of mooring restraints is to be considered.

3.1.4 The wind heeling moment curve is to be calculated for a sufficient number of heel angles to define the curve. For ship-shaped hulls the curve may be assumed to vary as the cosine function of vessel heel.

3.1.5 Wind heeling moments derived from wind tunnel tests on a representative model of the unit may be considered as alternatives to the method given in [3.1.2] to [3.1.4]. Such heeling moment determination is to include lift and drag effects at various applicable heel angles.

4 Intact stability criteria

4.1

4.1.1 The stability of a unit in each mode of operation is to meet the following criteria (see also Fig 1).

- a) For surface and self-elevating units the area under the righting moment curve to the second intercept or downflooding angle, whichever is less, is to be not less than 40% in excess of the area under the wind heeling moment curve to the same limiting angle.
- b) For column-stabilized units the area under the righting moment curve to the angle of downflooding is to be not less than 30% in excess of the area under the wind heeling moment curve to the same limiting angle.
- c) The righting moment curve is to be positive over the entire range of angles from upright to the second intercept.
- d) A check is to be carried out to assess that the lesser of the downflooding angle and the second intercept angle is not greater than the following angles:
 - 1) the angle for which the stresses of whichever primary structural element become excessive;
 - 2) the limit angle for which lashes of loads on the decks are calculated.

4.1.2 Each unit is to be capable of attaining a severe storm condition in a period of time consistent with the meteorological conditions. The procedures recommended and the approximate length of time required, considering both operating conditions and transit conditions, are to be contained in the Operating Manual.

It is to be possible to achieve the severe storm condition without the removal or relocation of solid consumables or other variable load. However, the Society may permit loading a unit past the point at which solid consumables would have to be removed or relocated to go to severe storm condition under the following conditions, provided the allowable KG requirement is not exceeded:

- a) in a geographic location where weather conditions annually or seasonally do not become sufficiently severe to require a unit to go to severe storm condition, or
- b) where a unit is required to support extra deckload for a short period of time that falls well within a period for which the weather forecast is favourable.

The geographic locations, weather conditions and loading conditions in which this is permitted are to be identified in the Operating Manual.

4.1.3 Alternative stability criteria may be considered by the Society provided an equivalent level of safety is maintained and if they are demonstrated to afford adequate positive initial stability. In determining the acceptability of such criteria, the Society may consider at least the following and take into account as appropriate:

- a) environmental conditions representing realistic winds (including gusts) and waves appropriate for world-wide service in various modes of operation;
- b) dynamic response of a unit. Analysis is to include the results of wind tunnel tests, wave tank model tests, and non-linear simulation, where appropriate. Any wind and wave spectra used is to cover sufficient frequency ranges to ensure that critical motion responses are obtained;
- c) potential for flooding taking into account dynamic responses and wave profile in a seaway;
- d) susceptibility to capsizing considering the unit's restoration energy and the static inclination due to the mean wind speed and the maximum dynamic response;
- e) an adequate safety margin to account for uncertainties;
- f) equivalent damage and flooding criteria (see Appendix 4).

Figure 1 : Righting moment and heeling moment curves

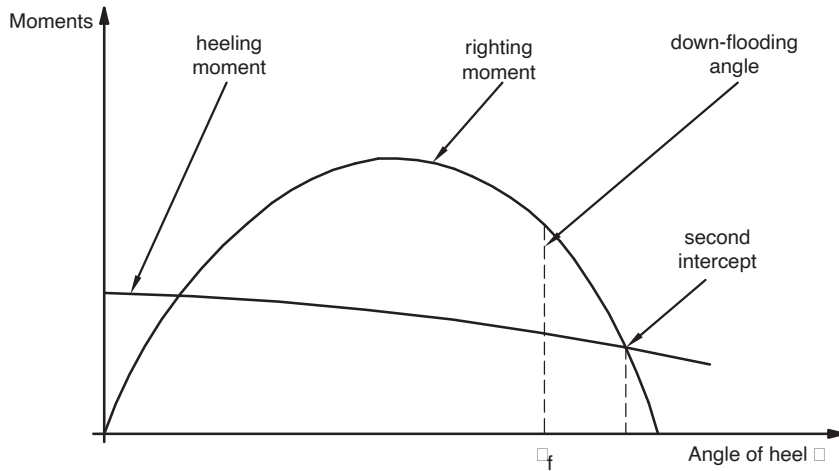

$$\text{Area (A + B)} > 1,4 \text{ or } 1,3 \text{ Area (B + C)}$$

5 Subdivision and damage stability

5.1 Surface and self-elevating units

5.1.1

The unit is to have sufficient freeboard and be subdivided by means of watertight decks and bulkheads to provide sufficient buoyancy and stability to withstand the flooding from the sea of any single compartment or any combination of compartments in any operating or transit condition consistent with the damage assumptions set out in item [6].

5.1.2 The unit is to have sufficient reserve stability in a damaged condition to withstand the wind heeling moment based on a wind velocity of 25,8 m/s (50 knots) superimposed from any direction. In this condition the final waterline, after flooding, is to be below the lower edge of any downflooding opening.

5.1.3

Self elevating and surface type units are to have sufficient stability as per [5.1.1], such that the final waterline is located below the lower edge of any opening that does not meet the watertight integrity requirements of [8.2.2].

For self-elevating units particularly, the flooding of any single compartment with the assumption of no wind while meeting the following criterion:

$$RoS = \theta_m - \theta_s \geq \text{Max } 7, (\theta_s) \text{ or } 5\theta_s$$

where:

RoS : range of stability, in degrees

θ_m : maximum angle of positive stability, in degrees

θ_s : static angle of inclination after damage, in degrees.

The range of stability is determined without reference to the angle of downflooding. Refer to Fig 2.

Figure 2 : Residual stability for self-elevating units

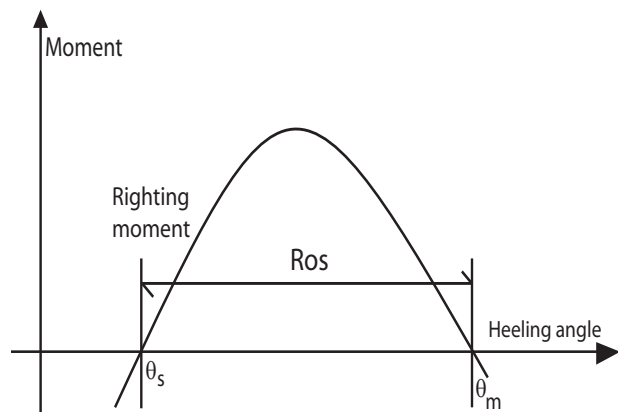

5.2 Column-stabilized units

5.2.1 The unit is to have sufficient freeboard and be subdivided by means of watertight decks and bulkheads to provide sufficient buoyancy and stability to withstand a wind heeling moment induced by a wind velocity of 25,8 m/s (50 knots) superimposed from any direction in any operating or transit condition, taking the following considerations into account:

- inclination after the damage set out in [6.3.1], b) is to not be greater than 17°;
- any opening below the final waterline is to be made watertight, and openings within 4 m above the final waterline are to be made weathertight;
- the righting moment curve, after the damage set out above, is to have, from the first intercept to the lesser of the extent of weathertight integrity required by b) and the second intercept, a range of at least 7°.

Within this range, the righting moment curve is to reach a value of at least twice the wind heeling moment curve, both being measured at the same angle (see Fig 2 below).

For alternative criteria see Appendix 3.

5.2.2

The unit is to provide sufficient buoyancy and stability in any operating or transit condition with the assumption of no wind to withstand the flooding of any watertight compartment wholly or partially below the waterline in question, which is a pump-room, a room containing machinery with a salt water cooling system or a compartment adjacent to the sea, taking the following considerations into account:

- the angle of inclination after flooding is to not be greater than 25°;
- any opening below the final waterline is to be made watertight;
- a range of positive stability is to be provided, beyond the calculated angle of inclination in these conditions, of at least 7°.

For alternative criteria see App 3.

5.2.3

Column stabilized units are to have sufficient stability as per [5.2.1] such that:

- the final waterline is located below the lower edge of any opening that does not meet the watertight integrity requirements of 8.2.2 (Attention is drawn to 3.4.3 of the 2009 IMO MODU Code [Res A.1023(26)] which limits the inclination of the unit relative to this final waterline, to be not greater than 17 degrees. Refer to Fig.3. Compliance with this limitation may be required by some Administrations).
- within the provided extent of weathertight integrity the damage righting moment curve is to have a range of at least 7 degrees beyond its first intercept with the 25,8 m/sec (50 knots) wind heeling moment curve to its second intercept or downflooding angle, whichever is less.

Further, the damage righting moment curve is to reach a value of at least twice the wind heeling moment curve, both measured at the same angle. Refer to Fig 3.

- openings within 4 m above the final waterline are to be made weathertight.

Figure 3 : Residual damage stability requirements for column stabilized units

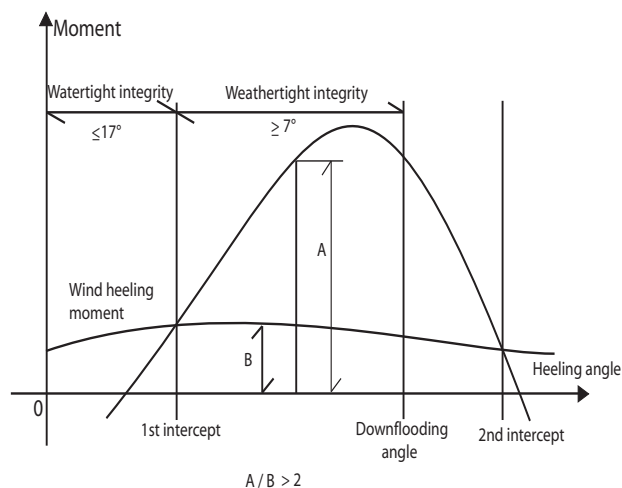

5.2.4

Column stabilized units are to have sufficient stability as per [5.2.2] such that:

- the equilibrium waterline is located below the lower edge of any opening that does not meet the watertight integrity requirements of [8.2.2] (Attention is drawn to 3.4.4 of the 2009 IMO MODU Code [Res A.1023(26)] which limits the inclination of the unit, relative to this equilibrium waterline, to be not greater than 25 degrees. Compliance with this limitation may be required by some Administrations).
- sufficient margin of stability is provided. (Attention is drawn to 3.4.4 of the 2009 IMO MODU Code [Res A.1023(26)] which requires a range of positive stability of at least 7 degrees beyond the first intercept of the righting moment curve and the horizontal coordinate axis of the static stability curve to the second intercept of them or the downflooding angle, whichever is less. Compliance with this range may be required by some Administrations).

5.3 All types of units

5.3.1

- Compliance with the requirements of items [5.1] and [5.2] is to be determined by calculations which take into consideration the proportions and design characteristics of the unit and the arrangements and configuration of the damaged compartments. In making these calculations, it is to be assumed that the unit is in the worst anticipated service condition as regards stability and is floating free of mooring restraints.

However, the possible detrimental effects of mooring restraints are to be considered.

- The ability to reduce angles of inclination by pumping out or ballasting compartments or application of mooring forces, etc., is not to be considered as justifying any relaxation of the requirements.
- For the purpose of stability calculations, tanks whose vents or overflows terminate on open decks or in locations assumed flooded, or in any event not above the final calculated water line in damage conditions, are to be considered flooded. Where the tanks are considered flooded, the locations where their vents and/or overflows terminate are also to be assumed flooded.

5.4

5.4.1 Alternative subdivision and damage stability criteria may be considered for approval by the Society provided an equivalent level of safety is maintained. In determining the acceptability of such criteria, the Society may consider at least the following and take into account:

- extent of damage as set out in item [6];
- on column-stabilized units, the flooding of any one compartment as set out in item [5.2.2];
- the provision of an adequate margin against capsizing.

6 Extent of damage

6.1 Surface units

6.1.1 In assessing the damage stability of surface units, the following extent of damage is to be assumed to occur between effective watertight bulkheads:

- a) horizontal penetration: 1,5 m; and
- b) vertical extent: from the base line upwards without limit.

6.1.2 The distance between effective watertight bulkheads or their nearest stepped portions which are positioned within the assumed extent of horizontal penetration is to be not less than 3,0 m; where there is a lesser distance, one or more of the adjacent bulkheads is to be disregarded.

6.1.3 Where damage of a lesser extent than in item [6.1.1] results in a more severe condition, such lesser extent is to be assumed.

6.1.4 All piping, ventilation systems, trunks, etc., within the extent of damage referred to in item [6.1.1] are to be assumed to be damaged. Positive means of closure are to be provided at watertight boundaries to preclude the progressive flooding of other spaces which are intended to be intact.

In addition, the compartments bounded by the bottom shell are to be considered flooded individually.

6.2 Self-elevating units

6.2.1 In assessing the damage stability of self-elevating units, the following extent of damage is to be assumed to occur between effective watertight bulkheads:

- a) horizontal penetration: 1,5 m; and
- b) vertical extent: from the base line upwards without limit.

6.2.2 The distance between effective watertight bulkheads or their nearest stepped portions which are positioned within the assumed extent of horizontal penetration is to be not less than 3,0 m; where there is a lesser distance, one or more of the adjacent bulkheads is to be disregarded.

6.2.3 Where damage of a lesser extent than in item [6.2.1] results in a more severe condition, such lesser extent is to be assumed.

6.2.4 Where a mat is fitted, the above extent of damage is to be applied to both the platform and the mat but not simultaneously, unless deemed necessary by the Society due to their close proximity to each other.

The simultaneous application of damage to both the platform and the mat are not to be considered only if the following conditions are met:

- a) at the maximum elevation the distance of any point of the mat from the plane of the water line is more than 1,5 m;
- b) the water line area is included in the area of the vertical projection, on its plane, of the mat and the distance of the boundary of said projection from the boundary of the water line is not less than 1,5 m.

6.2.5 All piping, ventilation systems, trunks, etc., within the extent of damage referred to in item [6.2.1] are to be assumed to be damaged. Positive means of closure are to be provided at watertight boundaries to preclude the progressive flooding of other spaces which are intended to be intact.

In addition, the compartments adjacent to the bottom shell are also to be considered flooded individually.

6.2.6 The recessed ends and sides of the drilling slot need not be subjected to horizontal penetration if warning signals are posted on each side of the vessel prohibiting any boat from approaching the drilling slot. Instructions to this effect are to be included in the Operating Manual.

6.3 Column stabilized units

6.3.1 In assessing the damage stability of column-stabilized units, the following extent of damage is to be assumed:

- a) Only those columns, underwater hulls and braces on the periphery of the unit are to be assumed to be damaged and the damage is to be assumed in the exposed portions of the columns, underwater hulls and braces.
- b) Columns and braces are to be assumed to be flooded by damage having a vertical extent of 3,0 m occurring at any level between 5,0 m above and 3,0 m below the draughts specified in the Operating Manual. Where a watertight flat is located within this region, the damage is to be assumed to have occurred in both compartments above and below the watertight flat in question. Lesser distances above or below the draughts may be applied to the satisfaction of the Society, taking into account the actual operating conditions.

However, the required damage region is to extend at least 1,5 m above and below the draught specified in the Operating Manual.

- c) No vertical bulkhead is to be assumed to be damaged, except where bulkheads are spaced closer than a distance of one eighth of the column perimeter at the draught under consideration, measured at the periphery, in which case one or more of the bulkheads is to be disregarded.
- d) Horizontal penetration of damage is to be assumed to be 1,5 m.
- e) Underwater hull or footings are to be assumed to be damaged when operating in a transit condition in the same manner as indicated in a), b), d) and either c) or item [6.2.2], having regard to their shape.

- f) All piping, ventilation systems, trunks, etc., within the extent of damage are to be assumed to be damaged. Positive means of closure are to be provided at watertight boundaries to preclude the progressive flooding of other spaces which are intended to be intact.

In addition, the compartments bounded by the bottom shells are to be considered flooded individually.

- g) If damage of a lesser extent results in a more severe final equilibrium condition, such lesser extent is to be assumed.

7 Watertight integrity

7.1 General

7.1.1 All units are to be provided with watertight bulkheads. In all cases, the plans submitted are to clearly indicate the location and extent of the bulkheads.

7.1.2 Watertight subdivision bulkheads are to have scantlings as required assuming a head equal to the greatest water head relevant to the unit in damage conditions.

7.1.3 Where watertight boundaries are required for damage stability, they are to be made watertight throughout, including piping, ventilation, shafting, electrical penetrations, etc. For compliance with the requirements of damage stability, where individual lines, ducts or piping systems serve more than one compartment or are within the extent of damage, satisfactory arrangements are to be provided to preclude the possibility of progressive flooding through the system to other spaces, in the event of damage.

7.1.4 The number of openings in watertight subdivisions is to be kept to a minimum compatible with the design and proper working of the unit. Where penetrations of watertight decks and bulkheads are necessary for access, piping, ventilation, electrical cables, etc., arrangements are to be made to maintain the watertight integrity of the enclosed compartments.

7.1.5 Where valves are provided at watertight boundaries to maintain watertight integrity, these valves are to be capable of being operated from a pump-room or other normally manned space, a weather deck, or a deck which is above the final waterline after flooding.

In the case of a column-stabilized unit this would be the central ballast control station.

Valve position indicators are to be provided at the remote control station.

7.1.6 For self-elevating units the ventilation system valves required to maintain watertight integrity are to be kept closed when the unit is afloat. Necessary ventilation in this case is to be arranged by alternative approved methods.

7.1.7 In the case of column-stabilized drilling units, the scantlings of the watertight flats and bulkheads are to be made effective to that point necessary to meet the requirements of damage stability and are to be indicated on the appropriate plans.

7.1.8 All surface type units are to be fitted with a collision bulkhead. Sluice valves, cocks, manholes, watertight doors, etc. are not to be fitted in the collision bulkhead.

Elsewhere, watertight bulkheads are to be fitted as necessary to provide transverse strength and subdivision.

7.2 Tank boundaries

7.2.1 Tanks for fresh water or fuel oil, or any other tanks which are not intended to be kept entirely filled in service, are to have divisions or deep swashes as may be required to minimize the dynamic stress on the structure. Tight divisions and boundary bulkheads of all tanks are to be constructed in accordance with Tasneef Rules.

The arrangement of all tanks, together with their intended service and the height of the overflow pipes, is to be clearly indicated on the plans submitted for approval.

Consideration is to be given to the density of the liquid in the tank.

7.2.2 Tanks are to be tested in accordance with Part A depending on the service of the tanks.

8 Closing appliances

8.1 General requirements related to intact stability

8.1.1 Closing appliances are to be as required by applicable load line requirements, except that special consideration will be given to openings in the upper deck of the upper hull of column-stabilized drilling units.

8.2 General requirements related to damage stability

8.2.1 General requirements related to watertight integrity

a) The means to ensure the watertight integrity of internal openings are to comply with the following:

- 1) Doors and hatch covers which are used during the operation of the unit while afloat are to be remotely controlled from the central ballast control station and are also to be operable locally from each side.

Open/shut indicators are to be provided at the control station.

In addition, remotely operated doors provided to ensure the watertight integrity of internal openings which are used while at sea are to be sliding watertight doors with audible alarm. The power, control and indicators are to be operable in the event of main power failure. Particular attention is to be paid to minimizing the effect of control system failure. Each power-operated sliding watertight door shall be provided with an individual handoperated mechanism. It shall be possible to open and close the door by hand at the door itself from both sides.

- 2) Doors or hatch covers in self-elevating units, or doors placed above the deepest load line draft in column-stabilized and surface units, which are nor-

mally closed while the unit is afloat may be of the quick acting type and should be provided with an alarm system (e.g., light signals) showing personnel both locally and at the central ballast control station whether the doors or hatch covers in question are open or closed. A notice should be affixed to each such door or hatch cover stating that it is not to be left open while the unit is afloat.

- 3) The closing appliances are to have strength, packing and means for securing which are sufficient to maintain the watertight integrity of the division on which they are fitted under the design water head of the watertight boundary of the flooded compartment.
- b) The means to ensure the watertight integrity of internal openings are to comply with the following:
- 1) a notice is to be affixed to each such closing appliance stating that it is to be kept closed while the unit is afloat; however, manholes fitted with close bolted covers need not be so marked
 - 2) on self-elevating units, and also on other units, an entry is to be made in the official logbook or tour report, as applicable, stating that all such openings have been witnessed closed before the unit becomes waterborne.
 - 3) The closing appliances are to have strength, packing and means for securing which are sufficient to maintain the watertight integrity of the division on which they are fitted under the design water head of the watertight boundary of the flooded compartment.
- c) All downflooding openings the lower edge of which is submerged when the unit is inclined to the first intercept between the righting moment and wind heeling moment curves in any intact or damaged condition are to be fitted with a suitable watertight closing appliance, such as closely spaced bolted covers.

In any case, the lower edges of air pipes (regardless of closing appliances), ventilators, ventilation intakes and outlets, non-watertight hatches and weathertight doorways are not to be submerged. Openings, such as side scuttles of the non-opening type, manholes and small hatches, which are fitted with appliances to ensure watertight integrity, may be submerged.

Such openings are not allowed in the columns of column-stabilized units.

Such openings are not to be regarded as emergency exits.

External openings, such as air pipes (regardless of closing appliances), ventilators, ventilation intakes and outlets, nonwatertight hatches and weathertight doors, which are used during operation of the unit while afloat, are not to submerge when the unit is inclined to the first intercept of the righting moment and wind heeling moment curves in any intact or damaged condition.

- d) Where flooding of chain lockers or other buoyant volumes may occur, the openings to these spaces are to be considered as downflooding points.

8.2.2 General requirements related to weathertight integrity

Any opening, such as an air pipe, ventilator, ventilation intake or outlet, non-watertight sidescuttle, small hatch, door, etc., having its lower edge submerged below a waterline associated with the zones indicate in a) or b) below, is to be fitted with a weathertight closing appliance to ensure the weathertight integrity, when:

- a) a unit is inclined to the range between the first intercept of the right moment curve and the wind heeling moment curve and the angle necessary to comply with the requirements of 3.1.1 during the intact condition of the unit while afloat; and
- b) a column stabilized unit is inclined to the range:
 - 1) necessary to comply with the requirements of 5.2.3 (b) and with a zone measured 4.0 m perpendicularly above the final damaged waterline per 5.2.3 a) referred to Fig.4, and
 - 2) necessary to comply with the requirements of 5.2.4 (b).

External openings fitted with appliances to ensure weathertight integrity, which are kept permanently closed while afloat are to comply with the requirements of [8.2.1], b), 1) and 2).

Figure 4 : Residual damage stability requirements for column stabilized units

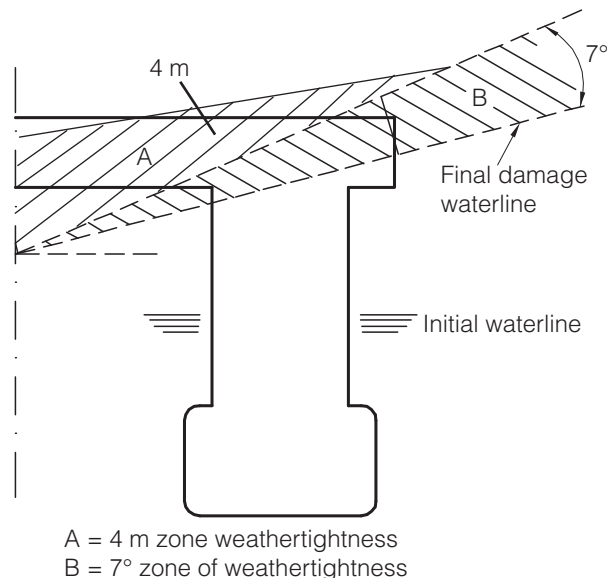

9 Freeboard

9.1 General

9.1.1 The requirements of the 1966 Load Line Convention, including those relating to certification, are to apply to all units and certificates are to be issued as appropriate. The minimum freeboard of units which cannot be computed by the normal methods laid down by that Convention is to be determined on the basis of meeting the applicable intact stability, damage stability and structural requirements for transit conditions and drilling operations while afloat. The

freeboard is not to be less than that computed from the Convention where applicable.

9.1.2 The requirements of the 1966 Load Line Convention with respect to weathertightness and watertightness of decks, superstructures, deckhouses, doors, hatchway covers, other openings, ventilators, air pipes, scuppers, inlets and discharges, etc., are to be taken as a basis for all units in the floating condition.

9.1.3 In general, heights of hatch and ventilator coamings, air pipes, door sills, etc., in exposed positions and their means of closing are to be determined by consideration of both intact and damage stability requirements.

- a) All downflooding openings which may become submerged before the angle of inclination at which the required area under the intact righting arm curve is achieved are to be fitted with weathertight closing appliances.
- b) With regard to damage stability, the requirements in [5.2.1] b), [5.2.2] and [8.2.1], c) are to apply.
- c) Society is to give special consideration to the position of openings which cannot be closed in emergencies, such as air intakes for emergency generators, having regard to the intact righting arm curves and the final waterline after assumed damage.

9.2 Surface units

9.2.1 Load lines are to be assigned to surface units as calculated under the terms of the 1966 Load Line Convention and are to be subject to all the conditions of assignment of that Convention.

9.2.2 Where it is necessary to assign a greater than minimum freeboard to meet intact or damage stability requirements or on account of any other restriction imposed by the Society, Regulation 6(6) of the 1966 Load Line Convention is to apply. When such a freeboard is assigned, seasonal marks above the centre of the ring are not to be marked and any seasonal marks below the centre of the ring are to be marked. If a unit is assigned a greater than minimum freeboard at the request of the owner, Regulation 6(6) need not apply.

9.3 Self-elevating units

9.3.1 Load lines are to be assigned to self-elevating units as calculated under the terms of the 1966 Load Line Convention. When floating or when in transit from one operational area to another units are to be subject to all the conditions of assignment of that Convention unless specifically exempted.

However, these units are not to be subject to the terms of that Convention while they are supported by the sea-bed or are in the process of lowering or raising their legs.

9.3.2 Where it is necessary to assign a greater than minimum freeboard to meet intact or damage stability require-

ments or on account of any other restriction imposed by the Administration, Regulation 6(6) of the 1966 Load Line Convention is to apply. When such a freeboard is assigned, seasonal marks above the centre of the ring are not to be marked and any seasonal marks below the centre of the ring are to be marked. If a unit is assigned a greater than minimum freeboard at the request of the owner, Regulation 6(6) need not apply.

9.3.3 Self-elevating units may be manned when under tow. In such cases a unit would be subject to a bow height requirement which may not always be possible to achieve.

In such circumstances, the Society is to consider the extent of application of Regulation 39(3) of the 1966 Load Line Convention to such units, having regard to the occasional nature of such voyages on predetermined routes and to prevailing weather conditions, subject to the acceptance of the Flag Administration.

9.3.4 Some self-elevating units utilize a large mat or similar supporting structure which contributes to the buoyancy when the unit is floating.

In such cases the mat or similar supporting structure is to be ignored in the calculation of freeboard. The mat or similar supporting structure is, however, always to be taken into account in the evaluation of the stability of the unit when floating since its vertical position relative to the upper hull may be critical.

9.4 Column-stabilized units

9.4.1 The hull form of this type of unit makes the calculation of geometric freeboard in accordance with the provisions of Chapter III of the 1966 Load Line Convention impracticable.

Therefore the minimum freeboard of each column-stabilized unit is to be determined by meeting the applicable requirements for:

- a) the strength of the unit's structure;
- b) the minimum clearance between passing wave crests and deck structure; and
- c) intact and damage stability requirements.

9.4.2 The minimum freeboard is to be marked in appropriate locations on the structure.

9.4.3 The enclosed deck structure of each column-stabilized unit is to be made weathertight.

9.4.4 Windows, sidescuttles and portlights, including those of the non-opening type, or other similar openings are not to be located below the deck structure of column-stabilized units.

9.4.5 The Society is to give special consideration to the position of openings which cannot be closed in emergencies, such as air intakes for emergency generators, having regard to the intact righting arm curves and the final waterline after assumed damage.

SECTION 4

MACHINERY

1 Machinery installations for all types of units

1.1 General

1.1.1 The requirements of this section apply to MODUs in addition to, and when indicated in lieu of, those in Pt C, Ch 1.

1.1.2 The machinery and electrical requirements contained in this Section provide an acceptable degree of protection for personnel from fire, electric shock or other physical injuries. The requirements apply to both marine and industrial equipment.

1.1.3 Codes and standards of practice which have been proven to be effective by actual application by the offshore drilling industry which are not in conflict with this Code, and which are acceptable to the Society, may be applied in addition to these requirements.

1.1.4 All machinery, electrical equipment, boilers and other pressure vessels, associated piping systems, fittings and wiring are to be of a design and construction adequate for the service for which they are intended and are to be so installed and protected as to reduce to a minimum any danger to persons on board, due regard being paid to moving parts, hot surfaces and other hazards. The design is to have regard to materials used in construction, and to the marine and industrial purposes for which the equipment is intended, the working conditions and the environmental conditions to which it will be subjected.

Consideration is to be given to the consequences of the failure of systems and equipment essential to the safety of the unit.

1.1.5 The requirements of this item apply in lieu of those in Pt C, Ch 1, Sec 1, [2.5] of the Rules for the Classification of Ships.

All machinery, components and systems essential to the safe operation of a unit are to be designed to operate under the following static conditions of inclination:

- a) when column-stabilized units are upright and inclined to an angle up to 15° in any direction;
- b) when self-elevating units are upright and inclined to an angle up to 10° in any direction;
- c) when surface units are upright and in level trim and when inclined to an angle of list up to 15° either way and simultaneously trimmed to an angle up to 5° by the bow or stern.

The Society may permit or require deviations from these angles, taking into consideration the type, size and service conditions of the unit.

1.1.6 Jacking mechanisms for self-elevating units are in general to be arranged with redundancy so that a single failure of any component does not cause an uncontrolled descent of the unit.

1.1.7 Means are to be provided whereby normal operation of vital systems, such as ballast systems in semisubmersible units, jacking systems in self-elevating units or control of blow-out preventers, can be sustained or restored even though one of the essential auxiliaries becomes inoperable.

1.1.8 Means are to be provided to ensure that machinery can be brought into operation from the "dead ship" condition without external aid.

1.2 Arrangements for oil fuel, lubricating oil and other flammable oils

1.2.1 The requirements of this item apply in lieu of the ones in Pt C, Ch 1, Sec 1, [2.9] of the Rules for the Classification of Ships.

Flash points mentioned in this subparagraph are intended to be determined by closed cup test.

Where it is intended to burn fuels of a flash point equal to or less than 60°C but not less than 43°C, this fact is to be indicated clearly on the arrangement submitted for approval. Vent heads of an approved type with wire gauze flame arrestors are to be fitted to vent pipes. Consideration may be given to other arrangements. The use of fuels of a flash point lower than 43°C will require special consideration of storage and handling facilities and controls as well as of the electrical installation and ventilation provisions.

1.3 Installation of internal combustion engines and boilers

1.3.1 Generally, combustion engines are not to be installed in hazardous areas. When this cannot be avoided, special consideration may be given to the arrangement.

Fired boilers are not to be installed in hazardous areas.

Exhaust outlets of internal combustion engines are to be fitted with effective spark arresting devices and are to discharge outside hazardous areas.

Exhaust outlets of fired boilers are to discharge outside hazardous areas.

Air intakes for internal combustion engines are to be not less than 3 m from hazardous areas.

1.4 Machinery controls

1.4.1 Machinery essential for the safety of the unit is to be provided with effective means for its operation and control.

1.4.2 Automatic starting, operational and control systems for machinery essential for the safety of the unit are to be in general, include provisions for manually overriding the automatic controls. Failure of any part of the automatic and remote control system are not to prevent the use of the manual override.

Visual indication is to be provided to show whether or not the override has been actuated.

1.5 Pumping and piping systems

1.5.1 General requirements

Pipes are to be arranged inboard of the zone of assumed damage penetration unless special consideration has been taken in the damage stability review.

Piping systems carrying non-hazardous fluids are generally to be separate from piping systems which may contain hazardous fluids. Cross connection of the piping systems may be permitted where means for avoiding possible contamination of the non-hazardous fluid system by the hazardous medium are provided.

1.5.2 Inlet and discharge valves

Inlet and discharge valves in compartments situated below the assigned load line (normally unattended compartments) are to be provided with remote control. Where remote operation is provided by power actuated valves for seawater inlets and discharges for operation of propulsion and power generating machinery, power supply failure of the control system is not to result in:

- a) closing of open valves;
- b) opening of closed valves.

Consideration may be given to accepting bilge alarms in lieu of remote operation for surface type and self-elevating units only.

1.5.3 Steam and air systems

Where steam or air is used to atomize well bore fluids prior to flaring, a non-return valve is to be fitted in the steam or air line. This valve is to be part of the permanently installed piping, readily accessible and as close as possible to the burner boom. Alternative arrangements shown to provide an equivalent level of safety may be accepted by the Society.

1.5.4 Bilge systems

The requirements in this item apply in lieu of the ones in Pt C, Ch 1, Sec 9, [6.2], [6.3.1], [6.7.1], [6.7.2] and [6.8] of the Rules for the Classification of Ships.

An efficient bilge pumping system is to be provided, capable of pumping from and draining watertight compartments other than spaces permanently appropriated for the carriage of fresh water, water ballast, oil fuel or liquid cargo and for which other efficient means of pumping are provided, under all practical conditions whether the unit is upright or inclined, as specified in [1.1.5].

Additional suction are to be provided in large compartments or compartments of unusual form, as deemed necessary by the Society. Arrangements are to be made whereby water in the compartment may find its way

to the suction pipes. Compartments not provided with a bilge suction may be drained to other spaces provided with bilge pumping capability. Means are to be provided to detect the presence of water in such compartments which are adjacent to the sea or adjacent to tanks containing liquids and in void compartments through which pipes conveying liquids pass.

If the Society is satisfied that the safety of the unit is not impaired, the bilge pumping arrangements and the means to detect the presence of water may be dispensed with in particular compartments.

At least two self-priming power pumps connected to each bilge main are to be provided. Sanitary, ballast and general service pumps may be accepted as independent power bilge pumps if fitted with the necessary connections to the bilge pumping system.

The cross-sectional area of the main bilge line is to be not less than the combined areas of the two largest branch suction.

The internal diameter of branch suction from each compartment is to be not less than the value given by the following formula, to the nearest 5 mm:

$$d = 2,15 \cdot A^{0,5} + 25 \text{ mm}$$

where A is the wetted surface, in m², of the compartment, excluding stiffening members, when the compartment is half-filled with water. The internal diameter of any bilge line is to be not less than 50 mm.

Each bilge pump is to be capable of giving a speed of water through the bilge main of not less than 2 m per second. When more than two pumps are connected to the bilge system, their aggregate capacity is not to be less effective.

Propulsion machinery rooms or pump rooms in lower hulls of column-stabilized units which are normally unattended is to be provided with two independent systems of high level detection.

Hazardous and non-hazardous areas are to be provided with separate drainage or pumping arrangements.

All distribution boxes and manually operated valves in connection with the bilge pumping arrangements are to be in positions which are accessible under ordinary circumstances. Where such valves are located in normally unmanned spaces below the assigned load line and not provided with high bilge water level alarms, they are to be operable from outside the space.

A means to indicate whether a valve is open or closed is to be provided at each location from which the valve can be controlled. The indicator is to rely on movement of the valve spindle.

Drainage of hazardous areas are to be given special consideration having regard to the risk of explosion (see Sec 5, [5.3.9]).

Chainlockers are to be capable of being drained by a permanently installed bilge or drainage system or by portable means. Means are to be provided for removal of mud and debris from the bilge or drainage system.

The following additional requirements are applicable to column-stabilized units.

- a) Chain lockers which, if flooded, could substantially affect the unit's stability are to be provided with a

remote means to detect flooding and a permanently installed means of dewatering. Remote indication of flooding are to be provided at the central ballast control station.

- b) At least one of the pumps referred to above and pump-room bilge suction valves are to be capable of both remote and local operation.
- c) Propulsion rooms and pump-rooms in lower hulls are to be provided with two independent systems for high bilge water level detection providing an audible and visual alarm at the central ballast control station.

1.5.5 Ballast system

The requirements in this item apply in lieu of the ones in Pt C, Ch 1, Sec 10, [7] of the Rules for the Classification of Ships.

The unit is to be provided with at least two independently driven ballast pumps for ballasting and de-ballasting of tanks to ensure the safe operation of the unit.

Consideration will be given to alternative arrangements.

The ballast system is to be arranged to prevent the inadvertent transfer of ballast water from one quadrant to any other quadrant of the unit.

Where the pumping arrangement consists of a multiple-pump system, the loss of any one pump are to not prevent the unit being de-ballasted sufficiently to an approved safety position.

Means for ballast control during submersion and raising of column-stabilized units are to be provided; specific instructions are to be included in the Operating Manual.

Control against accidental opening of flooding valves for all modes of operation, including the possible need to blank systems not in use during these operations, are to be provided.

Sea inlets and discharge valves in compartments located below the assigned load line, which generally are not accessible during the normal working conditions, are to be provided with remote controlled valves approved by the Society.

All valves are to be provided with an indicating system showing their effected operations and independent of the valve control.

1.5.6 Ballast pumping arrangements on column-stabilized units

The requirements in this item apply in lieu of the ones in Pt C, Ch 1, Sec 10, [7] of the Rules for the Classification of Ships.

Units are to be provided with an efficient pumping system capable of ballasting and deballasting any ballast tank under normal operating and transit conditions. Alternatively, the Society may permit controlled gravity ballasting.

The ballast system is to provide the capability to bring the unit, while in an intact condition, from the maximum normal operating draught to a severe storm draught, or to a greater distance, as may be specified by the Society, within 3 hours.

The ballast system is to be arranged to provide at least two independent power driven pumps so that the system remains operational in the event of failure of any one such pump. The pumps provided need not be dedicated ballast pumps, but are to be readily available for such use at all times.

The ballast system is to be capable of operating after the damage specified in Sec 3, [6.3] and have the capability of restoring the unit to a level trim and safe draught condition without taking on additional ballast, with any one pump inoperable. The Society may permit counter-flooding as an operational procedure.

The ballast pumps are to be of the self-priming type or be provided with a separate priming system.

The ballast system is to be arranged and operated so as to prevent inadvertent transfer of ballast water from one tank or hull to another, which could result in moment shifts leading to excessive angles of heel or trim.

It is to be possible to supply each required ballast pump from the emergency source of power. The arrangements are to be such that the system is capable of restoring the unit from an inclination specified in [1.1.5], a) to a level trim and safe draught condition after loss of any single component in the power supply system.

All ballast pipes are to be of steel or other suitable material having properties acceptable to the Society. Special consideration is to be given to the design of ballast lines passing through ballast tanks, taking into account effects of corrosion or other deterioration.

All valves and operating controls are to be clearly marked to identify the function they serve. Means are to be provided locally to indicate whether a valve is open or closed.

Air pipes are to be provided on each ballast tank sufficient in number and cross-sectional area to permit the efficient operation of the ballast pumping system. In order to allow deballasting of the ballast tanks intended to be used to bring the unit back to normal draught and to ensure no inclination after damage, air pipe openings for these tanks are to be above the worst damage waterline specified in Sec 3. Such air pipes are to be positioned outside the extent of damage, as defined in Sec 3.

Control and indicating systems are to comply with the following:

- a) A central ballast control station is to be provided. It is to be located above the worst damage waterline and in a space not within the assumed extent of damage referred to in Sec 3 and adequately protected from weather. It is to be provided with the following control and indicating systems where applicable:
 - 1) ballast pump control system;
 - 2) ballast pump status-indicating system;
 - 3) ballast valve control system;
 - 4) ballast valve position-indicating system;
 - 5) tank level-indicating system;
 - 6) draught indicating system;
 - 7) heel and trim-indicators;

- 8) power availability indicating system (main and emergency);
 - 9) ballast system hydraulic/pneumatic pressure-indicating system.
- b) In addition to remote control of the ballast pumps and valves from the central ballast control station, all ballast pumps and valves are to be fitted with independent local control operable in the event of remote control failure. The independent local control of each ballast pump and of its associated ballast tank valves are to be in the same location.
 - c) The control and indicating systems listed in a) are to function independently of one another, or have sufficient redundancy, such that a failure in one system does not jeopardize the operation of any of the other systems.
 - d) Each power-actuated ballast valve is to fail to the closed position upon loss of control power. Upon reactivation of control power, each such valve is to remain closed until the ballast control operator assumes control of the reactivated system. The Society may accept ballast valve arrangements that do not fail to the closed position upon loss of power provided the Society is satisfied that the safety of the unit is not impaired.
 - e) The tank level indicating system required by a), 5) is to provide means to:
 - 1) indicate liquid levels in all ballast tanks. A secondary means of determining levels in ballast tanks, which may be a sounding pipe, is to be provided. Tank level sensors are not to be situated in the tank suction lines;
 - 2) indicate liquid levels in other tanks, such as fuel oil, fresh water, drilling water or liquid storage tanks, the filling or emptying of which, in the view of the Society, could affect the stability of the unit. Tank level sensors are not to be situated in the tank suction lines.
 - f) The draught indicating system is to indicate the draught at each corner of the unit or at representative positions as required by the Society.
 - g) Enclosures housing ballast system electrical components, the failure of which would cause unsafe operation of the ballast system upon liquid entry into the enclosure, is to comply with Pt C, Ch 2, Sec 2, [7].
 - h) A means to indicate whether a valve is open or closed are to be provided at each location from which the valve can be controlled. The indicators are to rely on movement of the valve spindle.
 - i) Means are to be provided at the central ballast control station to isolate or disconnect the ballast pump control and ballast valve control systems from their sources of electrical, pneumatic or hydraulic power.

Internal communication system is to be provided complying with the following a permanently installed means of communication, independent of the unit's main source of electrical power, are to be provided between the central ballast control station and spaces that contain

ballast pumps or valves, or other spaces that may contain equipment necessary for the operation of the ballast system.

1.5.7 Protection against flooding

Each seawater inlet and discharge in spaces below the assigned load line are to be provided with a valve operable from an accessible position outside the space on:

- a) all column-stabilized units;
- b) all other units where the space containing the valve is normally unattended and is not provided with high bilge water level detection.

The control systems and indicators provided in Sec 3, [8.2.1] are to be operable in both normal conditions and in the event of main power failure. Where stored energy is provided for this purpose, its capacity is to be to the satisfaction of the Society.

1.5.8 Vents and overflows

Tank vents and overflows are to be located giving due regard to damage stability and the location of the final calculated waterline in the assumed damage condition.

Tank vents and overflows which could cause progressive flooding are to be avoided unless special consideration has been taken in the damage stability review.

In cases where tank vents and overflows terminate externally or in spaces assumed flooded, the vented tanks are to also be considered flooded.

In cases where tanks are considered damaged, the spaces in which their vents or overflows terminate are to also be considered flooded.

Vents and overflows from tanks not considered flooded as a result of damage and located above the final calculated waterline may be required to be fitted with automatic means of closure.

1.5.9 Vent pipes protection (1/7/2022)

Location and arrangement of vent pipes serving fuel oil tanks and lubrication tanks are to be done in a way providing protection against ingress of seawater or rain water in case of accidental vent pipes damage.

1.5.10 Sounding arrangements

All tanks are to be provided with separate sounding pipes, or approved remote level indicating system.

The internal diameter of sounding pipes is to generally be not less than 38 mm.

Where a sounding pipe exceeds 20 m in length, the minimum internal diameter is to be increased to at least 50 mm.

Where a remote level indicating system is used, an additional sounding system is to be provided for tanks which are not always accessible.

1.5.11 High pressure piping for drilling operations

Permanently installed piping systems for drilling operations are to comply with national or international standards or codes recognized by the Society.

1.6 Position keeping systems and components

1.6.1 Anchoring systems

a) General

Plans showing the arrangement and complete details of the anchoring system, including anchors, shackles, anchor lines consisting of chain, wire or rope, together with details of fairleads, windlasses, winches, and any other components of the anchoring system are to be submitted to the Society.

b) Design

1) An analysis of the anchoring arrangements expected to be utilized in the unit's operation are to be submitted to the Society.

Among the items to be addressed are:

- design environmental conditions of waves, winds, currents, tides and ranges of water depth;
- air and sea temperature;
- ice conditions (if applicable);
- description of analysis methodology.

2) Anchoring arrangements, where fitted as the sole means for position keeping, are to be provided with adequate factors of safety and be designed to maintain the unit on station in all design conditions. The arrangements are to be such that a failure of any single component or anchor line are not to cause progressive failure of the remaining anchoring arrangements.

In particular, sufficient numbers of heading angles together with the most severe combination of wind, current and wave are to be considered, usually from the same direction, to determine the maximum tension in each mooring line.

When a particular site is being considered, any applicable cross sea conditions are also to be considered in the event that they might induce higher mooring loads.

3) When the Quasi Static Method is applied, the tension in each anchor line is to be calculated at the maximum excursion for each design condition defined in 4), combining the following steady state and dynamic responses of the unit:

- steady mean offset due to the defined wind, current, and steady wave forces;
- most probable maximum wave induced motions of the moored unit due to wave excitation.

For relatively deep water, the effect from damping and inertia forces in the anchor lines are to be considered in the analysis.

The effects of slowly varying motions are to be included for units when the magnitudes of such motions are considered to be significant.

4) When the Quasi Static Method outlined in 3) is applied, the minimum factors of safety (FOS) at the maximum excursion of the unit for a range of headings (design condition) indicated in Tab 1 are to be considered.

When a dynamic analysis is employed, other safety factors may be considered to the satisfaction of the Society.

The defined operating and severe storm conditions are to be the same as those identified for the design of the unit, unless the Society is satisfied that lesser conditions may be applicable to specific sites.

5) In general, the maximum wave induced motions of the moored unit about the steady mean offset are to be obtained by means of model tests. The Society may accept analytical calculations provided that the proposed method is based on a sound methodology which has been validated by model tests.

In the consideration of column-stabilized units, the values of C_s and C_{Hr} , as indicated in Sec 3, may be introduced in the analysis for position keeping mooring systems.

The provisions of Sec 3, [3.1.5] and [4.1.3] may also be considered.

6) The Society may accept different analysis methodologies provided that it is satisfied that a level of safety equivalent to that obtained by 2) and 4) is ensured.

7) Special consideration is to be given to arrangements where the anchoring systems provided are used in conjunction with thrusters to maintain the unit on station.

Table 1

Design condition	FOS
operating	2,7
severe storm	1,8
operating - one line failed	1,8
severe storm - one line failed	1,25
$FOS = \frac{PB}{T_{max}} = \text{factor of safety}$ <p>T_{max} : characteristic tension in the anchor line, equal to the maximum value obtained according to 3)</p> <p>PB : minimum rated breaking strength of the anchor line</p> <p>operating: the most severe design environmental condition for normal operations as defined by the owner or designer</p> <p>severe storm: the most severe design environmental condition for severe storm as defined by the owner or designer</p> <p>operating - one line failed: following the failure of any one mooring line in the operating condition</p> <p>severe storm - one line failed: following the failure of any one mooring line in the severe storm condition.</p>	

1.6.2 Equipment

a) Windlasses

1) The design of the windlasses is to provide for adequate dynamic braking capacity to control normal combinations of loads from the anchor,

anchor cable and anchor handling vessel during the deployment of the anchors at the maximum design payout speed of the windlass.

The attachment of the windlass to the hull structure is to be designed to withstand the breaking strength of the anchor line.

- 2) Each windlass is to be provided with two independent power-operated brakes. Each brake is to be capable of holding against a static load in the anchor cable of at least 50% of its breaking strength. Where the Society so allows, one of the brakes may be replaced by a manually operated brake.

- 3) On loss of power to the windlasses, the power-operated braking system is to be automatically applied and be capable of holding against 50% of the total static braking capacity of the windlass.

Each windlass is to be capable of being controlled from a position which provides a good view of the operation.

- b) Fairleads and sheaves

Fairleads and sheaves are to be designed to prevent excessive bending and wear of the anchor cable. The attachments to the hull or structure are to be such as to adequately withstand the stresses imposed when an anchor cable is loaded to its breaking strength.

1.6.3 Anchor line

- a) It is to be ensured that the anchor lines are of a type that will satisfy the design conditions of the anchoring system.
- b) Means are to be provided to enable the anchor cable to be released from the unit after loss of main power.
- c) Means are to be provided for measuring anchor line tensions.
- d) Anchor lines are to be of adequate length to prevent uplift of the anchors under the maximum design conditions for the anticipated area(s) of operation.

1.6.4 Anchors

- a) Type and design of anchors are to be to the satisfaction of the Society.
- b) Suitable anchor stowage arrangements are to be provided to prevent movement of the anchors in a seaway.

1.6.5 Quality control

- a) Details of the quality control of the manufacturing process of the individual anchoring system components are to be submitted.
- b) The anchors, cables, shackles and other associated connecting equipment are to be designed, manufactured and tested in accordance with a recognized standard.

Evidence, to the satisfaction of the Society, that the equipment has been so tested and approved are to be readily available. Provisions are to be made on board for the recording of changes to and inspection of the equipment. Anchor cables may be of wire, rope, chain or any combination thereof.

1.6.6 Control stations

- a) A manned control station is to be provided with means to:
 - 1) indicate cable tension; and
 - 2) indicate speed and direction of wind.
- b) Reliable means are to be provided to communicate between locations critical to the anchoring operation.
- c) Means are to be provided at the windlass control position to:
 - 1) monitor cable tension and windlass power load; and
 - 2) indicate the amount of cable paid out.

1.6.7 Dynamic positioning systems

Dynamic positioning systems used as a sole means of position keeping are to provide a level of safety equivalent to that provided for anchoring arrangements (see Note 1).

Units provided with position keeping systems equipment in accordance with the Pt F, Ch 6, Sec 2 may obtain the additional class notation **DYNAPOS**.

Note 1: Reference is made to the "Guidelines for Vessels with Dynamic Positioning Systems" approved by the Maritime Safety Committee of IMO at its 63rd session and disseminated by circular MSC/Circ. 645.

1.7 Jacking system

1.7.1 The jacking system is to be designed and constructed to maintain the safety of the unit in the event of failure of a critical component during operation of the jacking system. Suitable monitoring is to be provided at a manned control station to indicate such failure.

1.8 Mud system level alarms

1.8.1 Suitable audible and visual alarms to indicate significant increase or decrease in the level of the contents of the mud pits are to be provided at the control station for drilling operations and at the mud pits.

Equivalent means to indicate possible abnormal conditions in the drilling system may be considered by the Society.

2 Additional requirements for machinery and electrical installations of self-propelled units

2.1 General

2.1.1 The requirements of this Chapter apply to units which are designed to undertake self-propelled passages without external assistance and are not applicable to units which are fitted only with means for the purpose of positioning or of assistance in towing operations. These requirements are additional to those in [1].

2.1.2 For propulsion system reference is to be made to the relevant rule requirements of Pt C, Ch 1 of the Rules for Classification of Ships.

2.1.3 Means are to be provided whereby normal operation of propulsion machinery can be sustained or restored even

though one of the essential auxiliaries becomes inoperative. Special consideration is to be given to the malfunction of:

- a) a generator set which serves as a main source electrical power;
- b) the sources of steam supply;
- c) the arrangements for boiler feedwater;
- d) the arrangements which supply fuel oil for boilers or engines;
- e) the sources of lubricating oil pressure;
- f) the sources of water pressure;
- g) a condensate pump and the arrangements to maintain vacuum in condensers;
- h) the mechanical air supply for boilers;
- i) an air compressor and receiver for starting or control purposes; and
- j) the hydraulic, pneumatic or electrical means for control in main propulsion machinery including controllable pitch propellers.

However, the Society, having regard to overall safety considerations, may accept a partial reduction in capability from full normal operation

2.1.4 Main propulsion machinery and all auxiliary machinery essential to the propulsion and the safety of the unit are to as fitted in the unit, be capable of operating under the static conditions required by [1.1.5] and the following dynamic conditions:

- a) column-stabilized unit; 22,5° in any direction;
- b) self elevating units: 15° in any direction;
- c) surface units 22,5° rolling and simultaneously pitching 7,5° by bow or stern.

The Society may permit deviation from these angles, taking into consideration the type, size and service conditions of the unit.

2.1.5 Special consideration is to be given to the design, construction and installation of propulsion machinery systems so that any mode of their vibrations does not cause undue stresses in this machinery in the normal operating ranges.

2.2 Means of going astern

2.2.1 Units are to have sufficient power for going astern to secure proper control of the unit in all normal circumstances.

2.2.2 The ability of the machinery to reverse the direction of thrust of the propeller in sufficient time and so to bring the unit to rest within a reasonable distance from maximum ahead service speed is to be demonstrated.

2.2.3 The stopping times, unit headings and distances recorded on trials, together with the results of trials to determine the ability of units having multiple propellers to navigate and manoeuvre with one or more propellers

inoperative, are to be available on board for the use of the master or other designated personnel.

Note 1: Reference is made to the 'Recommendation on the Provision and Display of Manoeuvring Information on Board Ships' adopted by auto with, Resolution A.601 (15).

2.2.4 Where the unit is provided with supplementary means for manoeuvring or stopping, these are to be demonstrated and recorded as referred to in [2.2.2] and [2.2.3].

2.3 Steam boilers and boiler feed systems

2.3.1 Water tube boilers serving turbine propulsion machinery are to be fitted with a high-water-level alarm.

2.3.2 Every steam generating system which provides services essential for the propulsion of the unit is to be provided with not less than two separate feedwater systems from and including the feed pumps, noting that a single penetration of the steam drum is acceptable.

Means are to be provided which will prevent over pressure in any part of the systems.

2.4 Machinery controls

2.4.1 Main and auxiliary machinery essential for the propulsion of the unit are to be provided with effective means for its operation and control. A pitch indicator is to be provided on the navigating bridge for controllable pitch propellers.

2.4.2 Where remote control of propulsion machinery from the navigating bridge is provided and the machinery spaces are intended to be manned, the following are to apply:

- a) the speed, direction of thrust and, if applicable, the pitch of the propeller are to be fully controllable from the navigating bridge under all sailing condition, including manoeuvring;
- b) the remote control is to be performed, for each independent propeller, by a control device so designed and constructed that its operation does not require particular attention to the operational details of the machinery. Where more than one propeller is designed to operate simultaneously, these propellers may be controlled by one control device;
- c) the main propulsion machinery is to be provided with an emergency stopping device on the navigating bridge and independent from the bridge control system;
- d) propulsion machinery orders from the navigating bridge are to be indicated in the main machinery control station or at the manoeuvring platform as appropriate;
- e) remote control of the propulsion machinery is to be possible from only one station at a time; at one control station interconnected control units are permitted. There is to be at each station an indicator showing which station is in control of the propulsion machinery. The transfer of control between navigating bridge and

machinery space is to be possible only in the machinery space or machinery control room;

- f) it is to be possible to control the propulsion machinery locally, even in the case of failure in any part of the remote control system;
- g) the design of the remote control system is to be such that in case of its failure an alarm will be given and the preset speed and direction of thrust be maintained until local control is in operation, unless the Society considers it impracticable;
- h) indicators are to be fitted on the navigating bridge for:
 - 1) propeller speed and direction in the case of fixed pitch propellers;
 - 2) propeller speed and pitch position in the case of controllable pitch propellers;
- i) an alarm is to be provided at the navigating bridge and in the machinery space to indicate low starting air pressure set at a level which still permits main engine starting operations. If the remote control system of the propulsion machinery is designed for automatic starting, the number of automatic consecutive attempts which fail to produce a start are to be limited to safeguard sufficient starting air pressure for starting locally.

2.4.3 Where the main propulsion and associated machinery including sources of main electrical supply are provided with various degrees of automatic or remote control and are under continuous manned supervision from a control room, this control room is to be designed, equipped and installed so that the machinery operation will be as safe and effective as if it were under direct supervision; for this purpose Pt F, Ch 2, Sec 1 [3] and [4] apply as appropriate. Particular consideration is to be given to protection against fire and flooding,

2.5 Steering gear

2.5.1 Main and auxiliary steering gear

- a) Except as provided for in [2.5.2], units are to be provided with main steering gear and auxiliary steering gear to the satisfaction of the Society. The main steering gear and the auxiliary steering gear are to be so arranged that a single failure in one of them so far as is reasonable and practicable will not render the other one inoperative.
- b) The main steering gear is to be of adequate strength and sufficient to steer the unit at maximum service speed and this is to be demonstrated. The main steering gear and rudder stock are to be so designed they will not be damaged at maximum astern speed but this design requirement does not need to be proved by trials at maximum astern speed and maximum rudder angle.
- c) The main steering gear is to be, with the unit at its deepest seagoing draught, capable of putting the rudder over from 35° on one side to 35° on the other side with the unit running ahead at maximum service speed. The rudder is to be capable of being put over from 35° on

either side to 30° on the other side in not more than 28 seconds, under the same conditions

- d) The main steering gear is to be operated by power where necessary to fulfil the requirements of c) and in any case in which the Society requires a rudder stock of over 120 mm diameter in way of the tiller.
- e) The main steering gear power unit or units are to be arranged to start automatically when power is restored after a power failure.
- f) The auxiliary steering gear is to be of adequate strength and sufficient to steer the unit at navigable speed and capable of being brought speedily into action in an emergency.
- g) The auxiliary steering gear is to be capable of putting the rudder over from 15° on one side to 15° on the other side in not more than 60 seconds with the unit at its deepest seagoing draught while running at one half of its maximum speed ahead or seven knots, whichever is the greater,
- h) The auxiliary steering gear is to be operated by power where necessary to fulfil the requirements of g), and in any case in which the Society requires a rudder stock of over 230 mm diameter in way of the tiller.
- i) Where the main steering gear comprises two or more identical power units auxiliary steering gear need not be fitted if the main steering gear is capable of operating the rudder as required by c) while operating with all power units.

As far as is reasonable and practicable the main steering gear is to be so arranged that a single failure in its piping or in one of the power unit will not impair the integrity of the remaining part of the steering gear.

- j) Control of the main steering gear is to be provided both on the navigating bridge and in the steering gear compartment, If the steering gear control system which provides for control from the navigating bridge is electric, it is to be supplied from the steering gear power circuit from a point within the steering gear compartment.

When the main steering gear is arranged according to i) two independent control systems are to be provided, each of which can be operated from the navigating bridge. Where the control system comprises a hydraulic telemotor, the Society may waive the requirements for a second independent control system.

Where the auxiliary steering gear is power operated, it is to be provided with a control system operated from the navigating bridge and this is to be independent of the control system for the main steering gear.

Means are to be provided in the steering gear compartment to disconnect the steering gear control system from the power circuit.

- k) A means of communication is to be provided between the navigating bridge and the steering gear compartment.
- l) The exact angular position of the rudder, if power operated, is to be indicated on the navigating bridge.

The rudder angle indication is to be independent of the steering gear control system.

The angular position of the rudder is to be recognizable in the steering gear compartment.

- m) An alternative power supply, sufficient at least to supply a steering gear power unit which complies with the requirement of g) and also its associated control system and the rudder angle indicator, are to be provided, automatically, within 45 seconds, either from the emergency source of electrical power, or from another independent source of power located in the steering gear compartment. This independent source of power is to be used only for this purpose and is to have a capacity sufficient for at least 10 minutes of continuous operation.

2.5.2 Non-conventional rudder

Where a non-conventional rudder is installed, or where a unit is steered by means other than a rudder, the Society is to give special consideration to the steering system so as to ensure that an acceptable degree of reliability and effectiveness, which is based on [2.5.1] a), is provided.

2.6 Electric and electrohydraulic steering gear

2.6.1 Indicators for running indication of the motors of electric and electrohydraulic steering gear are to be installed on the navigating bridge and at a suitable machinery control position.

2.6.2

- a) Each electric or electrohydraulic steering gear comprising one or more power units are to be served by at least two circuits fed from the main switchboard.

One of the circuits may pass through the emergency switchboard. Auxiliary electric or electrohydraulic steering gear associated with main electric or

electrohydraulic steering gear may be connected to one of the circuits supplying this main steering gear. The circuits supplying electric or electrohydraulic steering gear are to have adequate rating for supplying all motors which can be simultaneously connected to it and have to operate simultaneously,

- b) Short-circuit protection and an overload alarm are to be provided for these circuits and motors. Protection against excess current, if provided, is to be for not less than twice the full load current of the motor or circuit so protected, and is to be arranged to permit the passage of the appropriate starting currents. Where a three-phase supply is used, an alarm is to be provided that will indicate failure of any one of the supply phases. The alarms required in the subparagraph are to be both audible and visual and be situated in a position on the navigating bridge where they can be readily observed.

2.7 Communication between the navigating bridge and the engine-room

2.7.1 Units are to be provided with at least two independent means for communicating orders from the navigating bridge to the position in the machinery space or control room from which the engines are normally controlled. One of these is to be an engine-room telegraph providing visual indication of the orders and responses both in the engine-room and on the navigating bridge. Consideration is to be given to providing a means of communication to any other positions from which the engines may be controlled.

2.8 Engineer's alarm

2.8.1 An engineer's alarm is to be provided to be operated from the engine control room or at the manoeuvring platform, as appropriate, and clearly audible in the engineer's accommodation.

SECTION 5

ELECTRICAL INSTALLATIONS

1 General

1.1 Application

1.1.1 The requirements in this Section apply to MODU in addition to (and when indicated in replacement of) those contained in Part C, Chapter 2.

1.2 Documentation to be submitted

1.2.1 In addition to the documents requested in Pt C, Ch 2, Sec 1, Tab 1 of the Rules for the Classification of Ships the following are to be submitted for approval:

- a) plan of hazardous areas
- b) document giving details of types of cables and safety characteristics of the equipment installed in hazardous areas.

1.3 Power sources location

1.3.1 Sources of electrical power and their section boards and distribution boards, etc., are normally not to be located in hazardous locations.

1.3.2 The generating plant, switchboards and batteries are to be separated from any zone 0 by cofferdams or equivalent spaces and from other hazardous areas by gas-tight steel divisions.

1.3.3 Access between such spaces has to comply with [5.3.8].

2 Main plant

2.1 Shaft generators

2.1.1 The arrangement of the unit's main source of power is to be such that essential services can be maintained regardless of the speed and direction of the main propelling engines or shafting.

2.1.2 The generating plant is to be such as to ensure that with any one generator or its primary source of power out of operation, the remaining generator or generators will be capable of providing the electrical services necessary to start the main propulsion plant from a dead ship condition. The emergency generator may be used for the purpose of starting from a dead ship condition if its capability either alone or combined with that of any generator is sufficient to provide at the same time those services required by [4.2.8].

2.2 Requirement for self propelled units

2.2.1 For electrically self-propelled units the application of Pt C, Ch 2, Sec 2, [3.2.5] need only include for propulsion sufficient power to ensure safe navigation when under way.

2.2.2 The main switchboard is to be so placed relative to one main generating station that, as far as is practicable the integrity of the normal supply may be affected only by a fire or other casualty in one space. An environmental enclosure for the main switchboard, such as may be provided by a machinery control room situated within the main boundaries of the space, is not to be considered as separating the switchboards from the generators.

2.2.3 Where the main source of electrical power is necessary for propulsion and steering of the unit, the system is to be so arranged that the electrical supply to equipment necessary for propulsion and steering and to ensure safety of the unit will be maintained or immediately restored in the case of loss of any one of the generators in service.

2.2.4 Where the main source of electrical power is necessary for propulsion of the ship, the main busbar is to be subdivided into at least two parts which are normally to be connected by circuit breakers or other approved means; so far as is practicable, the connection of generating sets and other duplicated equipment is to be equally divided between the parts.

2.2.5 Electrically operated speed control systems of main engines are to be fed from the main source of electrical power.

2.2.6 Where more than one main propulsion engine is foreseen, each speed control system is to be provided with an individual supply by means of separate wiring from the main switchboard or from two independent section boards. Being the main bus-bars divided into at least two sections, the governors are, as far as practicable, to be supplied equally from the two sections.

2.2.7 In the case of propulsion engines which do not depend for their operation on electrical power, i.e. pumps driven from the main engine, the speed control systems are to be fed both from the main source of electrical power and from an accumulator battery for at least 15 minutes or from a similar supply source.

Such battery may also be used for other services such as automation systems, where foreseen.

2.2.8 Steering gear circuits are to be provided with short-circuit protection only.

2.2.9 In case of electrical propulsion plants see Sec 6.

3 Shore connection

3.1 Shore supply

3.1.1 Where arrangements are made for supplying the electrical installation from a source on shore or elsewhere, a suitable connection box is to be installed on the unit in a convenient location to receive the flexible cable from the external source.

3.1.2 Permanently fixed cables of adequate rating are to be provided for connecting the box to the main switchboard or emergency switchboard.

3.1.3 Where necessary for systems with earthed neutrals, the box is to be provided with an earthed terminal for connection between the shore's and unit's neutrals or for connection of a protective conductor.

3.1.4 The connection box is to contain a circuit-breaker or a switch-disconnector and fuses.

The shore connection is to be protected against short-circuit and overload; however, the overload protection may be omitted in the connection box if provided on the main or emergency switchboard.

3.1.5 Means are to be provided for checking the phase sequence of the incoming supply in relation to the unit's system.

3.1.6 The cable connection to the box is to be provided with at least one switch-disconnector on the main or emergency switchboard.

3.1.7 The shore connection is to be provided with an indicator at the main or emergency switchboard in order to show when the cable is energized.

3.1.8 At the connection box a notice is to be provided giving full information on the nominal voltage and frequency of the installation.

3.1.9 The switch-disconnector on the main or emergency switchboard is to be interlocked with the generator circuit-breakers in order to prevent its closure when any generator is supplying the main or emergency switchboard unless special provisions to the satisfaction of the Society are taken to permit safe transfer of electrical load.

3.1.10 Adequate means are to be provided to equalize the potential between the hull and the shore when the electrical installation of the unit is supplied from shore.

3.1.11 Provisions are to be made for securing the trailing cables to the framework so that mechanical stress is not applied to the electrical terminals.

3.1.12 Any transformer used for shore-connection is to be of the double-wound type.

3.1.13 The maximum short-circuit rating of the distribution system is to be higher than the short-circuit level of the shore supply system.

3.1.14 Permanently fixed cables connecting the shore connection box to the main or emergency switchboard are to be protected by fuses or circuit-breakers.

4 Emergency plant

4.1 Application

4.1.1 The requirements of Pt C, Ch 2, Sec 2, [3.3], [4.4] and [5] are replaced by those of [4.2].

4.2 Emergency source of electrical power

4.2.1 Every unit should be provided with a self-contained emergency source of electrical power.

4.2.2 The emergency source of power, any associated transforming equipment, the transitional source of emergency power and the emergency switchboard are to be located above the worst damage waterline and in a space not within the assumed extent of damage referred to in Sec 4, and be readily accessible.

They are not to be forward of the collision bulkhead, if any.

4.2.3 The location of the emergency source of power, any associated transforming equipment, the transitional source of emergency power and emergency switchboard in relation to the main source of electrical power is to be such as to ensure to the satisfaction of the Society that a fire or other casualty in the space containing the main source of electrical power or in any machinery space of Category A will not interfere with the supply or distribution of emergency power.

4.2.4 The emergency source of electrical power, any associated transforming equipment, the transitional source of emergency power and the emergency switchboard are not to be located in any space or spaces containing the main source of electrical power or other equipment presenting a fire risk nor in any room or compartment having direct access to such space or spaces.

4.2.5 As far as practical, the space containing the emergency source of power, any associated transforming equipment, the transitional source of emergency power and the emergency switchboard is not to be contiguous to boundaries of machinery spaces of Category A or of those spaces containing the main source of electrical power. Where the emergency source of power, any associated transforming equipment, the transitional source of emergency power, and the emergency switchboard are contiguous to the boundaries of machinery spaces of Category A or to those spaces containing the main source of electrical power, or to spaces of Zone 1 or Zone 2, the contiguous boundaries is to be in compliance with Pt C, Ch 4, Sec 2, [3].

4.2.6 Provided that suitable measures are taken for safeguarding independent emergency operation under all circumstances, the emergency switchboard may be used to supply non-emergency circuits, and the emergency generator may be used exceptionally and for short periods to supply non-emergency circuits.

4.2.7 For units where the main source of electrical power is located in two or more spaces which have their own systems, including power distribution and control systems completely independent of the systems in the other spaces and such that a fire or other casualty in any one of the spaces will not affect the power distribution from the others, or to the services required by [4.2.8], the requirements of [4.2.1] may be considered satisfied without an additional emergency source of electrical power, provided that the Society is satisfied that:

- a) there are at least two generating sets, meeting the requirements of [4.2.18] and each of sufficient capacity to meet the requirements of [4.2.8], in each of at least two spaces;
- b) the arrangements required by 4.2.7 (a) in each such space are equivalent to those required by [4.2.10] so that a source of electrical power is available at all times to the services required by [4.2.8];
- c) the location of each of the spaces referred to in [4.2.7] a), is in compliance with [4.2.2], and the boundaries meet the requirements of [4.2.3], [4.2.4] and [4.2.5], except that contiguous boundaries have to consist of an "A-60" bulkhead and a cofferdam, or a steel bulkhead insulated to class "A-60" on both sides.

4.2.8 The power available is to be sufficient to supply all those services that are essential for safety in an emergency, due regard being paid to such services as may have to be operated simultaneously.

The emergency source of power is to be capable, having regard to starting currents and the transitory nature of certain loads, of supplying simultaneously at least the following services for the periods specified hereinafter, if they depend upon an electrical source for their operation.

- a) For a period of 18 hours, emergency lighting:
 - at every embarkation station on deck and over sides;
 - in all service and accommodation alleyways, stairways and exits, personnel lift cars, and personnel lift trunks;
 - in the machinery spaces and main generating stations including their control positions;
 - in all control stations and in all machinery control rooms;
 - in all spaces from which control of the drilling process is performed and where controls of machinery essential for the performance of this process, or devices for emergency switching-off of the power plant are located;
 - at the stowage position or positions for firemen's outfits;
 - at the sprinkler pump, if any, at the fire pump referred to in e), at the emergency bilge pump, if any, and at their starting positions;
 - on helicopter landing decks;
 - at the steering gear.

- b) For a period of 18 hours:
 - the navigation lights,
 - other lights and sound signals, required by the International Regulations for the Prevention of Collisions at Sea, in force.
- c) For a period of 4 days:
 - any signalling lights, or
 - sound signals
 which may be required for marking of offshore structures.
- d) For a period of 18 hours:
 - all internal communication equipment that is required in an emergency;
 - fire and gas detection and their alarm systems;
 - intermittent operation of the manual fire alarms and all internal signals that are required in an emergency; and
 - the capability of closing the blow-out preventer and of disconnecting the unit from the well head arrangement, if electrically controlled;
 unless they have an independent supply from an accumulator battery suitably located for use in an emergency and sufficient for the period of 18 hours.
- e) For a period of 18 hours:
 - one of the fire pumps, if dependent upon the emergency generator for its source of power;
 - permanently installed diving equipment, if dependent upon the unit's electrical power;
 - radio communication installations;
 - equipment, operating on electric power, serving embarkation stations of survival craft for abandoning the unit.
- f) On column-stabilized units, for a period of 18 hours:
 - ballast control and indicating systems required by Sec 4, [1.5.5]; and
 - the largest of the ballast pumps required by Sec 4, [1.5.5]; only one of the connected pumps need be considered to be in operation at any time.
- g) For a period of half an hour:
 - power to operate the watertight doors as provided by Sec 3, [8.2.1]; but not necessarily all of them simultaneously, unless an independent temporary source of stored energy is provided;
 - power to operate the controls and indicators required by Sec 3, [8.2.1].
- h) For a period of 18 hours:
 - navigational aids as required by SOLAS Convention;
 - intermittent operation of the daylight signalling lamp and the unit's whistle;
 unless they have an independent supply from an accumulator battery suitably located for use in an emergency and sufficient for the period of 18 hours.
- i) For the period of 10 minutes:
 - the steering gear where it is required to be so supplied by Sec 4, [2.5.1].

4.2.9 The emergency source of power may be either a generator or an accumulator battery.

4.2.10 Where the emergency source of power is a generator it is to be:

- a) driven by a suitable prime mover with an independent supply of fuel, having a flashpoint of not less than 43°C;
- b) started automatically upon failure of the normal electrical supply unless a transitional source of emergency power in accordance with following item c) is provided; where the emergency generator is automatically started, it should be automatically connected to the emergency switchboard; those services referred to in [4.2.12] are then to be connected automatically to the emergency generator; and unless a second independent means of starting the emergency generator is provided, the single source of stored energy is to be protected to preclude its complete depletion by the automatic starting system; and
- c) provided with a transitional source of emergency power, as specified in [4.2.12], unless the emergency generator is capable of supplying the services mentioned in [4.2.12] and of being automatically started and supplying the required load as quickly as is safe and practicable but in not more than 45 seconds.

4.2.11 Where the emergency source of power is an accumulator battery it is to be capable of:

- a) carrying the emergency load without recharging while maintaining the voltage of the battery throughout the discharge period within plus or minus 12% of its nominal voltage;
- b) automatically connecting to the emergency switchboard in the event of failure of the main power supply; and
- c) immediately supplying at least those services specified in [4.2.12].

4.2.12 The transitional source or sources of emergency power, where required by [4.2.10] c), is to consist of an accumulator battery suitably located for use in an emergency, which has to operate without recharging whilst maintaining the voltage of the battery throughout the discharge period within plus or minus 12% of its nominal voltage, and be of sufficient capacity and so arranged as to supply automatically, in the event of failure of either the main or the emergency source of power, the following services for half an hour at least if they depend upon an electrical source for their operation:

- a) the lighting required by [4.2.8] a) and b). For this transitional phase, the required emergency lighting, in respect of the machinery space and accommodation and service areas, may be provided by permanently fixed, individual accumulator lamps which are automatically charged and operated;
- b) all essential internal communication equipment required by the first two items of [4.2.8] d); and
- c) intermittent operation of the services referred to in last two items of [4.2.8] d), unless in the case of preceding items b) and c) they have an independent supply from an accumulator battery suitably

located for use in an emergency and sufficient for the period specified.

4.2.13 The emergency switchboard is to be installed as near as is practicable to the emergency source of power and, where the emergency source of power is a generator, the emergency switchboard is preferably to be located in the same space.

4.2.14 No accumulator battery fitted in accordance with this requirement for emergency or transitional power supply is to be installed in the same space as the emergency switchboard, unless appropriate measures to the satisfaction of the Society are taken to extract the gases discharged from the said batteries.

4.2.15 An indicator is to be mounted in a suitable place on the main switchboard or in the machinery control room to indicate when the batteries constituting either the emergency source of power or the transitional source of power, referred to in [4.2.11] or [4.2.12] are being discharged.

4.2.16 The emergency switchboard is to be supplied in normal operation from the main switchboard by an interconnector feeder which is to be adequately protected at the main switchboard against overload and short circuit. The arrangement at the emergency switchboard is to be such that the interconnector feeder is disconnected automatically at the emergency switchboard upon failure of the main power supply. Where the system is arranged for feedback operation, from emergency to main switchboard, the interconnector feeder is also to be protected at the emergency switchboard at least against short circuit.

4.2.17 In order to ensure ready availability of emergency supplies, arrangements are to be made where necessary to disconnect non-emergency circuits automatically from the emergency switchboard to ensure that power is available automatically to the emergency circuits.

4.2.18 The emergency generator and its prime mover and any emergency accumulator battery are to be designed to function at full rated power when upright and when inclined up to the maximum angle of heel in the intact and damaged condition, as determined in accordance with Sec 4. In no case need the equipment be designed to operate when inclined more than:

- 25° in any direction on a column-stabilized unit;
- 15° in any direction on a self-elevating unit; and
- 22,5° about the longitudinal axis and/or when inclined 10° about the transverse axis on a surface unit.

4.2.19 Provision is to be made for the periodic testing of the complete emergency system. This should include the testing of automatic starting arrangements.

5 Electrical installations in hazardous location

5.1 Monitoring of circuits in hazardous areas

5.1.1 The devices intended to continuously monitor the insulation level of all distribution systems are also to monitor all circuits, other than intrinsically safe circuits, connected to apparatus in hazardous areas or passing through such areas.

An audible and visual alarm is to be given, at a manned position, in the event of an abnormally low level of insulation.

Systems fed by single transformers supplying one consumer or a control circuit do not require an earth fault detection.

5.2 Precautions against inlet of gases or vapours

5.2.1 Suitable arrangements are to be provided, to the satisfaction of the Society, so as to prevent the possibility of gases or vapours passing from a gas-dangerous space to another space through runs of cables or their conduits.

5.3 Hazardous location classification and permitted electrical equipment

5.3.1 Units are to be assessed with regard to any potential explosive gas atmosphere in accordance with the provisions of [5.3] or alternatively with an acceptable Code or Standard giving equivalent safety.

5.3.2 The results are to be documented in area classification drawings to allow the proper selection of all electrical components to be installed.

5.3.3 The hazardous location classification is to be carried out by those who have knowledge of the properties of flammable materials, the process and the equipment, in consultation with, as appropriate, safety, electrical, mechanical and other engineering personnel.

5.3.4 Classification of hazardous areas in ZONES is defined in Pt C, Ch 2, Sec 1 [3.24] of the Rules for the Classification of Ships.

5.3.5 Release as a result of accidental events such as blow-out or vessel rupture is not addressed by area classification. It is to be covered by emergency measures.

5.3.6 Openings, penetrations or connections between areas of different hazardous area classification are to be avoided, e.g. through ventilation systems, air pipes or drain systems.

5.3.7 Enclosed or semi-enclosed spaces (not containing a source of hazard) having a direct opening, including those for ventilation, into any hazardous area are to be designated as the same hazardous zone as the area in which the opening is located. See also [5.3.6] and [5.3.9]. Electrical

installations are to comply with the requirements for the space or area into which the opening leads.

5.3.8 (1/7/2022)

Except for operational reasons, access doors or other openings are not to be provided between a non-hazardous space and a hazardous area or between a zone 2 space and a zone 1 space. Where such access doors or other openings are provided, any non-hazardous enclosed space having a direct access to any zone 1 location or zone 2 location becomes the same zone as the location except that:

- a) an enclosed space with direct access to any zone 1 location can be considered as zone 2 if:
 - the access is fitted with a gastight door opening into the zone 2 space, and
 - ventilation is such that the air flow with the door open is from the zone 2 space into the zone 1 location, and
 - loss of ventilation is alarmed at a manned station;
- b) an enclosed space with direct access to any zone 2 location is not considered hazardous if:
 - the access is fitted with a self-closing gastight door that opens into the non-hazardous location, and
 - ventilation is such that the air flow with the door open is from the non-hazardous space into the zone 2 location, and
 - loss of ventilation is alarmed at a manned station;
- c) an enclosed space with direct access to any zone 1 location is not considered hazardous if:
 - the access is fitted with self-closing gastight doors forming an airlock, and
 - the space has ventilation overpressure in relation to the hazardous space, and
 - loss of ventilation overpressure is alarmed at a manned station.

Where ventilation arrangements for the intended safe space are considered sufficient by the Society to prevent any ingress of gas from the zone 1 location, the two self-closing doors forming an airlock may be replaced by a single self-closing gastight door which opens into the non-hazardous location and has no hold-back device.

Hold-back devices are not to be used on self-closing gastight doors forming hazardous area boundaries.

5.3.9 Piping systems are to be designed to preclude direct communication between hazardous areas of different classifications and between hazardous and non-hazardous areas.

5.4 Ventilation

5.4.1 For requirements of ventilation systems in hazardous areas, see Pt C, Ch 4, Sec 2, [3.5].

5.5 Protection in overpressure

5.5.1 For requirements relevant to protection in overpressure, see Pt C, Ch 4, Sec 2, [3.6].

5.6 Hazardous area

5.6.1 (1/7/2022)

The following are to be considered Zone 0 hazardous locations.

- a) The internal spaces of closed tanks and piping for containing active non-degassed drilling mud, oil that has a closed-cup flashpoint below 60°C or flammable gas and vapour, as well as produced oil and gas in which an oil/gas/air mixture is continuously present or present for long periods.

Active drilling mud is considered as being that mud in the system which is between the well and the final degassing discharge.

5.6.2 (1/7/2022)

The following are to be considered Zone 1 hazardous locations.

- a) Enclosed spaces containing any part of the mud circulating system that has an opening into the spaces and is between the well and the final degassing discharge. Any space containing testing facilities for oil or gas is to be specially considered.
- b) Enclosed spaces or semi-enclosed locations that are below the drill floor and contain a possible source of release such as the top of a drilling nipple.
- c) Enclosed spaces that are on the drill floor and which are not separated by a solid floor from the spaces in [5.6.2] b).
- d) In outdoor or semi-enclosed locations, except as provided for in [5.6.2] b), the area within 1,5 m from the boundaries of any openings to equipment which is part of the mud system as specified in [5.6.2] a), any ventilation outlets of Zone 1 spaces, or any access to Zone 1 spaces.
- e) Pits, ducts or similar structures in locations which would otherwise be Zone 2 but which are so arranged that dispersion of gas may not occur.
- f) Enclosed spaces which contain pits, ducts or similar structures which would otherwise be Zone 2 but which are arranged so that dispersion of gas may not occur.
- g) Outdoor locations below the drill floor and within a radius of 1.5 m from a possible source of release such as the top of a drilling nipple.

5.6.3 (1/7/2022)

The following are to be considered Zone 2 hazardous locations.

- a) Enclosed spaces which contain open sections of the mud circulating system from the final degassing discharge to the mud pump suction connection at the mud pit.
- b) Outdoor locations within the boundaries of the drilling derrick up to a height of 3 m above the drill floor.
- c) Semi-enclosed locations below and contiguous to the drill floor and to the boundaries of the derrick or to the extent of any enclosure which is liable to trap gases.

- d) Outdoor locations below the drill floor within a radius of 1,5 m area beyond the zone 1 area as specified in [5.6.2], g).
- e) The areas 1,5 m beyond the Zone 1 areas specified in [5.6.2] a) and beyond the semi-enclosed locations specified in [5.6.2] b).
- f) Outdoor areas within 1,5 m of the boundaries of any ventilation outlet from or access to a Zone 2.
- g) Semi-enclosed derricks to the extent of their enclosure above the drill floor or to a height of 3 m above the drill floor, whichever is greater.
- h) Air locks between Zone 1 areas and non-hazardous areas.

5.7 Permitted electrical equipment

5.7.1 Electrical equipment and cables installed in hazardous areas are to be limited to those necessary for operational purposes.

5.7.2 Portable electrical equipment, supplied by cables is not permitted in hazardous areas, unless special precautions are taken (see IEC 61892-7 clause 6.5).

5.7.3 For electrical cables see Pt C, Ch 2, Sec 2, [12.2].

5.7.4 The cross-section of cables installed in hazardous areas is to be correlated to the characteristics time/current of the relevant electrical protective device in order to limit the surface temperature of the cable to a safety value obliged by the temperature class of the dangerous gas likely to be present in the area, under the most severe expected fault condition.

5.7.5 Permitted certified safe type electrical equipment is to be chosen taking into account the more demanding of the required explosion groups and temperature classes of the products which may cause the presence of an explosive atmosphere in consequence of drilling, handling, processing (if any) and storing (if any) operations.

5.7.6 Permitted electrical equipment are indicated in Pt C, Ch 2, Sec 2, [12.1.3], [12.1.4], [12.1.5] and [12.1.6] as applicable.

5.7.7 For increased safety motors, due consideration is to be given to the protection against overcurrent, locked rotor, extended starting periods, etc., which could cause excessive temperatures.

5.7.8 Electrical apparatus and cables are, where practicable, to be excluded from any compartment in which explosive are stored. Where lighting is required, the light has to come from outside, through the boundaries of the compartment. If electrical equipment cannot be excluded from such a compartment it is to be so designed and used as to minimize the risk of fire or explosion.

SECTION 6

ELECTRIC PROPULSION PLANT

1 General

1.1 Applicable requirements

1.1.1 The following requirements apply to units for which the main propulsion plants are provided by at least one electric propulsion motor and its electrical supply. All electrical components of the propulsion plants are to comply with these requirements.

1.1.2 Prime movers are to comply with the requirements of Sec 4, [2.1.2].

1.1.3 For the torsional vibration characteristics of the electric propulsion plant, the provisions of Sec 4, [2.1.2] apply.

1.1.4 Cooling and lubricating oil systems are to comply with the requirements of Pt C, Ch 1, Sec 10 of the Rules for the Classification of Ships.

1.1.5 Monitoring and control systems are to comply with the requirements of Part C, Chapter 3.

1.1.6 Installations assigned an additional notation for automation are to comply with the requirements of Part F.

1.2 Operating conditions

1.2.1 The normal torque available on the electric propulsion motors for manoeuvring is to be such as to enable the vessel to be stopped or reversed when sailing at its maximum service speed.

1.2.2 Adequate torque margin is to be provided for three-phase synchronous motors to avoid the motor pulling out of synchronism during rough weather and when turning.

1.2.3 When an electric generating plant has a continuous rating greater than the electric propulsion motor rating, means are to be provided to limit the continuous input to the motor. This value is not to exceed the continuous full load torque for which motor and shafts are designed.

1.2.4 The plant as a whole is to have sufficient overload capacity to provide the torque, power and reactive power needed during starting and manoeuvring conditions.

Locked rotor torque which may be required in relation to the operation of the vessel (e.g. for navigation in ice) is to be considered.

1.2.5 The electric motors and shaftline are to be constructed and installed so that, at any speed reached in service, all the moving components are suitably balanced.

2 Design of the propulsion plant

2.1 General

2.1.1 The electrical power for the propulsion system may be supplied from generating sets, dedicated to the propulsion system, or from a central power generation plant, which supplies the unit's services and electric propulsion.

The minimum configuration of an electric propulsion plant consists of one prime mover, one generator and one electric motor. When the electrical production used for propulsion is independent of the shipboard production, the diesel engines driving the electric generators are to be considered as main engines.

2.1.2 For plants having only one propulsion motor controlled via a static convertor, a standby convertor which it is easy to switch over to is to be provided. Double stator windings with one convertor for each winding are considered as an alternative solution.

2.1.3 In electric propulsion plants having two or more constant voltage propulsion generating sets, the electrical power for the unit's auxiliary services may be derived from this source. Additional unit's generators for auxiliary services need not be fitted provided that effective propulsion and the services mentioned in Pt C, Ch 2, Sec 2, [3.2.5] are maintained with any one generating set out of service.

2.1.4 Plants having two or more propulsion generators, two or more static convertors or two or more motors on one propeller shaft are to be so arranged that any device may be taken out of service and disconnected electrically, without affecting the operation of the others.

2.2 Power supply

2.2.1 Where the plant is intended exclusively for electric propulsion, voltage variations and maximum voltage are to be maintained within the limits required in Pt C, Ch 2, Sec 2 of the Rules for the Classification of Ships.

2.2.2 In special conditions (e.g. during crash-stop manoeuvres), frequency variations may exceed the limits stipulated in Pt C, Ch 2, Sec 2 of the Rules for the Classification of Ships provided that other equipment operating on the same network is not unduly affected.

2.2.3 The electric plant is to be so designed as to prevent the harmful effects of electromagnetic interference generated by semiconductor convertors, in accordance with Pt C, Ch 2, Sec 2 of the Rules for the Classification of Ships.

2.3 Auxiliary machinery

2.3.1 Propeller/thruster auxiliary plants are to be supplied directly from the main switchboard or from the main distribution board or from a distribution board reserved for such circuits, at the auxiliary rated voltage.

2.3.2 When the installation has one or more lubrication systems, devices are to be provided to ensure the monitoring of the lubricating oil return temperature.

2.3.3 Propelling machinery installations with a forced lubrication system are to be provided with alarm devices which will operate in the event of oil pressure loss.

2.4 Electrical Protection

2.4.1 Automatic disconnections of electric propulsion plants which adversely affect the manoeuvrability of the unit are to be restricted to faults liable to cause severe damage to the equipment.

2.4.2 The following protection of convertors is to be provided:

- protection against overvoltage in the supply systems to which convertors are connected
- protection against overcurrents in semiconductor elements during normal operation
- short-circuit protection.

2.4.3 Overcurrent protective devices in the main circuits are to be set sufficiently high so that there is no possibility of activation due to the overcurrents caused in the course of normal operation, e.g. during manoeuvring or in heavy seas.

2.4.4 Overcurrent protection may be replaced by automatic control systems ensuring that overcurrents do not reach values which may endanger the plant, e.g. by selective tripping or rapid reduction of the magnetic fluxes of the generators and motors.

2.4.5 In the case of propulsion plants supplied by generators in parallel, suitable controls are to ensure that, if one or more generators are disconnected, those remaining are not overloaded by the propulsion motors.

2.4.6 In three-phase systems, phase-balance protective devices are to be provided for the motor circuit which de-excite the generators and motors or disconnect the circuit concerned.

2.5 Excitation of electric propulsion motor

2.5.1 Each propulsion motor is to have its own exciter.

2.5.2 For plants where only one generator or only one motor is foreseen, each machine is to be provided with a standby static electronic exciter, which it is easy to switch over to.

2.5.3 In the case of multi-propeller propulsion units, one standby static electronic exciter which it is easy to switch over to is to be provided.

2.5.4 For the protection of field windings and cables, means are to be provided for limiting the induced voltage when the field circuits are opened. Alternatively, the induced voltage when the field circuits are opened is to be maintained at the nominal design voltage.

2.5.5 In excitation circuits, there is to be no overload protection causing the opening of the circuit, except for excitation circuits with semiconductor convertors.

3 Construction of rotating machines and semiconductor convertors

3.1 Ventilation

3.1.1 Where electrical machines are fitted with an integrated fan and are to be operated at speeds below the rated speed with full load torque, full load current, full load excitation or the like, the design temperature rise is not to be exceeded.

3.1.2 Where electrical machines or convertors are force-ventilated, at least two fans, or other suitable arrangements, are to be provided so that limited operation is possible in the event of one fan failing.

3.2 Protection against moisture and condensate

3.2.1 Machines and equipment which may be subject to the accumulation of moisture and condensate are to be provided with effective means of heating. The latter is to be provided for motors above 500 kW, in order to maintain the temperature inside the machine at about 3°C above the ambient temperature.

3.2.2 Provision is to be made to prevent the accumulation of bilge water, which is likely to enter inside the machine.

3.3 Rotating machines

3.3.1 Electrical machines are to be able to withstand the excess speed which may occur during operation of the unit.

3.3.2 The design of rotating machines supplied by static convertors is to consider the effects of harmonics.

3.3.3 The winding insulation of electrical machines is to be capable of withstanding the overvoltage which may occur in manoeuvring conditions.

3.3.4 The design of a.c. machines is to be such that they can withstand without damage a sudden short-circuit at their terminals under rated operating conditions.

3.3.5 The obtainable current and voltage of exciters and their supply are to be suitable for the output required during manoeuvring and overcurrent conditions, including short-circuit in the transient period.

3.4 Semiconductor convertors

3.4.1 The following limiting repetitive peak voltages U_{RM} are to be used as a base for each semiconductor valve:

- when connected to a supply specifically for propeller drives:

$$U_{RM} = 1,5 U_p$$

- when connected to a common main supply:

$$U_{RM} = 1,8 U_p$$

where

U_p : is the peak value of the rated voltage at the input of the semiconductor convertor.

3.4.2 For semiconductor convertor elements connected in series, the values in [3.4.1] are to be increased by 10%. Equal voltage distribution is to be ensured.

3.4.3 For parallel-connected convertor elements, an equal current distribution is to be ensured.

3.4.4 Means are to be provided, where necessary, to limit the effects of the rate of harmonics to the system and to other semiconductor convertors. Suitable filters are to be installed to keep the current and voltage within the limits given in Pt C, Ch 2, Sec 2 of the Rules for the Classification of Ships.

4 Control and monitoring

4.1 General

4.1.1 The control and monitoring systems, including programmable electronic systems, are to be type approved, according to Pt C, Ch 3, Sec 6 of the Rules for the Classification of Ships.

4.2 Power plant control systems

4.2.1 The power plant control systems are to ensure that adequate propulsion power is available, by means of automatic control systems and/or manual remote control systems.

4.2.2 The automatic control systems are to be such that, in the event of a fault, the propeller speed and direction of thrust do not undergo substantial variations.

4.2.3 Failure of the power plant control system is not to cause complete loss of generated power (i.e. blackout) or loss of propulsion.

4.2.4 The loss of power plant control systems is not to cause variations in the available power; i.e. starting or stopping of generating sets is not to occur as a result.

4.2.5 Where power-aided control (for example with electrical, pneumatic or hydraulic aid) is used for manual operation, failure of such aid is not to result in interruption of power to the propeller, any such device is to be capable of purely manual operation.

4.2.6 The control system is to include the following main functions:

- monitoring of the alarms: any event critical for the proper operation of an essential auxiliary or a main element of the installation requiring immediate action to avoid a breakdown is to activate an alarm
- speed or pitch control of the propeller
- shutdown or slow down when necessary.

4.2.7 Where the electric propulsion system is supplied by the main switchboard together with the unit's services, load shedding of the non-essential services and /or power limitation of the electric propulsion is to be provided. An alarm is to be triggered in the event of power limitation or load shedding.

4.2.8 The risk of blackout due to electric propulsion operation is to be eliminated. At the request of the Society, a failure mode and effects analysis is to be carried out to demonstrate the reliability of the system.

4.3 Indicating instruments

4.3.1 In addition to the provisions of Part C, Chapter 3, instruments indicating consumed power and power available for propulsion are to be provided at each propulsion remote control position.

4.3.2 The instruments specified in [4.3.3] and [4.3.4] in relation to the type of plant are to be provided on the power control board or in another appropriate position.

4.3.3 The following instruments are required for each propulsion alternator:

- an ammeter on each phase, or with a selector switch to all phases
- a voltmeter with a selector switch to all phases
- a wattmeter
- a tachometer or frequency meter
- a power factor meter or a var-meter or a field ammeter for each alternator operating in parallel
- a temperature indicator for direct reading of the temperature of the stator windings, for each alternator rated above 500 kW.

4.3.4 The following instruments are required for each a.c. propulsion motor:

- an ammeter on the main circuit
- an embedded sensor for direct reading of the temperature of the stator windings, for motors rated above 500 kW
- an ammeter on the excitation circuit for each synchronous motor
- a voltmeter for the measurement of the voltage between phases of each motor supplied through a semiconductor frequency convertor.

4.3.5 Where a speed measuring system is used for control and indication, the system is to be duplicated with separate sensor circuits and separate power supply.

4.3.6 An ammeter is to be provided on the supply circuit for each propulsion semiconductor bridge.

4.4 Alarm system

4.4.1 An alarm system is to be provided, in accordance with the requirements of Part C, Chapter 3. The system is to give an indication at the control positions when the parameters specified in [4.4] assume abnormal values or any event occurs which can affect the electric propulsion.

4.4.2 Where an alarm system is provided for other essential equipment or installations, the alarms in [4.4.1] may be connected to such system.

4.4.3 Critical alarms for propulsion may be grouped, but are to be indicated to the bridge separately from other alarms.

4.4.4 The following alarms are to be provided, where applicable:

- high temperature of the cooling air of machines and semiconductor convertors provided with forced ventilation (see Note 1)
- reduced flow of primary and secondary coolants of machines and semiconductor convertors having a closed cooling system with a heat exchanger
- leakage of coolant inside the enclosure of machines and semiconductor convertors with liquid-air heat exchangers
- high winding temperature of generators and propulsion motors, where required (see [4.3])
- low lubricating oil pressure of bearings for machines with forced oil lubrication
- tripping of protective devices against overvoltages in semiconductor convertors (critical alarm)
- tripping of protection on filter circuits to limit the disturbances due to semiconductor convertors
- tripping of protective devices against overcurrents up to and including short-circuit in semiconductor convertors (critical alarm)
- voltage unbalance of three-phase a.c. systems supplied by semiconductor frequency convertors
- earth fault for the main propulsion circuit (see Note 2)
- earth fault for excitation circuits of propulsion machines (see Note 3).

Note 1: As an alternative to the air temperature of convertors or to the airflow, the supply of electrical energy to the ventilator or the temperature of the semiconductors may be monitored.

Note 2: In the case of star connected a.c. generators and motors with neutral points earthed, this device may not detect an earth fault in the entire winding of the machine.

Note 3: This may be omitted in brushless excitation systems and in the excitation circuits of machines rated up to 500 kW. In such cases, lamps, voltmeters or other means are to be provided to detect the insulation status under operating conditions.

4.5 Reduction of power

4.5.1 Power is to be automatically reduced in the following cases:

- low lubricating oil pressure of bearings of propulsion generators and motors
- high winding temperature of propulsion generators and motors
- fan failure in machines and convertors provided with forced ventilation, or failure of cooling system
- lack of coolant in machines and semiconductor convertors
- load limitation of generators or inadequate available power.

4.5.2 When power is reduced automatically, this is to be indicated at the propulsion control position (critical alarm).

4.5.3 Switching-off of the semiconductors in the event of abnormal service operation is to be provided in accordance with the manufacturer's specification.

5 Installation

5.1 Ventilation of spaces

5.1.1 Loss of ventilation to spaces with forced air cooling is not to cause loss of propulsion. To this end, two sets of ventilation fans are to be provided, one acting as a standby unit for the other. Equivalent arrangements using several independently supplied fans may be considered.

5.2 Cable runs

5.2.1 Instrumentation and control cables are to comply with the requirements of Pt C, Ch 3, Sec 5 of the Rules for the Classification of Ships.

5.2.2 Where there is more than one propulsion motor, all cables for any one machine are to be run as far as is practicable away from the cables of other machines.

5.2.3 Cables which are connected to the sliprings of synchronous motors are to be suitably insulated for the voltage to which they are subjected during manoeuvring.

6 Tests

6.1 Test of rotating machines

6.1.1 The test requirements are to comply with of Pt C, Ch 2, Sec 4 of the Rules for the Classification of Ships.

6.1.2 For rotating machines, such as synchronous generators and synchronous electric motors, of a power of more than 3 MW, a test program is to be submitted to the Society for examination.

6.1.3 In relation to the evaluation of the temperature rise, it is necessary to consider the supplementary thermal losses induced by harmonic currents in the stator winding. To this end, two methods may be used:

- direct test method, when the electric propulsion motor is being supplied by its own frequency converter, and/or back to back arrangement according to the supplier's facility
- indirect test method as defined in Pt C, Ch 2, App 1 of the Rules for the Classification of Ships; in this case, a validation of the estimation of the temperature excess due to harmonics is to be documented. A justification based on a computer program calculation may be taken into consideration, provided that validation of such program is demonstrated by previous experience.

7 Specific requirements for PODs

7.1 General

7.1.1 When used as steering manoeuvring system, the POD is to comply with the requirements of Sec 4, [2.5].

7.2 Rotating commutators

7.2.1 As far as the electrical installation is concerned, the electric motor is supplied by a rotating commutator which rotates with the POD. The fixed part of the power transmission is connected to the unit supply, which uses the same components as a conventional propulsion system. Sliding contacts with a suitable support are used between the fixed and rotating parts.

7.2.2 Type tests are to be carried out, unless the manufacturer can produce evidence based on previous experience indicating the satisfactory performance of such equipment on board units.

7.2.3 A test program is to be submitted to the Society for examination. It is to be demonstrated that the power transmission and transmission of low level signals are not affected by the environmental and operational conditions prevailing on board. To this end, the following checks and tests are to be considered:

- check of the protection index (I.P.), in accordance with the location of the rotating commutator
- check of the clearances and creepage distances
- check of insulation material (according to the test procedure described in IEC 60112)
- endurance test:

After the contact pressure and rated current are set, the commutator is subjected to a rotation test. The number of rotations is evaluated taking into consideration the unit operation and speed rotation control system. The

possibility of turning the POD 180° to proceed astern and 360° to return to the original position is to be considered. The commutator may be submitted to cycles comprising full or partial rotation in relation to the use of the POD as steering gear. The voltage drops and current are to be recorded.

An overload test is to be carried out in accordance with Pt C, Ch 2, Sec 4 (minimum 150%, 15 seconds) of the Rules for the Classification of Ships

- check of the behaviour of the sliprings when subjected to the vibration defined in Pt C, Ch 3, Sec 6 of the Rules for the Classification of Ships
- check of the behaviour of the sliprings, after damp heat test, as defined in Part C, Chapter 3, and possible corrosion of the moving parts and contacts

After the damp heat test, are to be carried out the here-under listed tests.

- Insulation measurement resistance test. The minimum resistance is to be in accordance with Pt C, Ch 2, Sec 4, Tab 3 of the Rules for the Classification of Ships
- Dielectric strength test as defined in Pt C, Ch 2, Sec 4 of the Rules for the Classification of Ships.

7.3 Electric motors

7.3.1 The thermal losses are dissipated by the liquid cooling of the bulb and by the internal ventilation of the POD. The justification for the evaluation of the heating balance between the sea water and air cooling is to be submitted to the Society.

Note 1: The calculation method used for the evaluation of the cooling system (mainly based on computer programs) is to be documented. The calculation method is to be justified based on the experience of the designer of the system. The results of scale model tests or other methods may be taken into consideration.

7.3.2 Means to adjust the air cooler characteristics are to be provided on board, in order to obtain an acceptable temperature rise of the windings. Such means are to be set following the dock and sea trials.

7.4 Instrumentation and associated devices

7.4.1 Means are to be provided to transmit the low level signals connected to the sensors located in the POD.

7.5 Additional tests

7.5.1 Tests of electric propulsion motors are to be carried out in accordance with Pt C, Ch 2, Sec 4 of the Rules for the Classification of Ships, and other tests in accordance with Sec 4, [2.1.2].

7.5.2 Tests are to be performed to check the validation of the temperature rise calculation.

SECTION 7

AUTOMATION

1 General

1.1 Application

1.1.1 The requirements in this Section apply to MODU in addition to those contained in Part C, Chapter 3.

2 Control of propulsion machinery

2.1 Remote control

2.1.1 The requirements in Pt C, Ch 3, Sec 2, [3] of the Rules for the Classification of Ships apply to propulsion machinery.

2.1.2 The design of the remote control system is to be such that in case of its failure an alarm will be given.

2.1.3 Supply failure (voltage, fluid pressure, etc.) in propulsion plant remote control is to activate an alarm at the control position. In the event of remote control system failure and unless the Society considers it impracticable, the preset speed and direction of thrust are to be maintained until local control is in operation. This applies in particular in the case of loss of electric, pneumatic or hydraulic supply to the system.

2.1.4 Propulsion machinery orders from the navigation bridge are to be indicated in the main machinery control room, and at the manoeuvring platform.

2.1.5 The control is to be performed by a single control device for each independent propeller, with automatic performance of all associated services, including, where necessary, means of preventing overload of the propulsion machinery. Where multiple propellers are designed to operate simultaneously, they must be controlled by one control device.

2.1.6 Indicators are to be fitted on the navigation bridge, in the main machinery control room and at the manoeuvring platform, for:

- propeller speed and direction of rotation in the case of fixed pitch propellers; and
- propeller speed and pitch position in the case of controllable pitch propellers.

2.1.7 The main propulsion machinery is to be provided with an emergency stopping device on the navigation bridge which is to be independent of the navigation bridge control system. In the event that there is no reaction to an order to stop, provision is to be made for an alternative emergency stop. This emergency stopping device may consist of a simple and clearly marked control device, for example a push-button. This fitting is to be capable of sup-

pressing the propeller thrust, whatever the cause of the failure may be.

2.2 Remote control from navigating bridge

2.2.1 Where propulsion machinery is controlled from the navigating bridge, the remote control is to include an automatic device such that the number of operations to be carried out is reduced and their nature is simplified and such that control is possible in both the ahead and astern directions. Where necessary, means for preventing overload and running in critical speed ranges of the propulsion machinery is to be provided.

2.2.2 On board units fitted with remote control, direct control of the propulsion machinery is to be provided locally. The local direct control is to be independent from the remote control circuits, and takes over any remote control when in use.

2.2.3 Each local control position, including partial control (e.g. local control of controllable pitch propellers or clutches) is to be provided with means of communication with each remote control position. The local control positions are to be independent from remote control of propulsion machinery and continue to operate in the event of a blackout.

2.2.4 Remote control of the propulsion machinery is to be possible only from one location at a time; at such locations interconnected control positions are permitted.

2.2.5 The transfer of control between the navigating bridge and machinery spaces is to be possible only in the main machinery space or the main machinery control room. The system is to include means to prevent the propelling thrust from altering significantly, when transferring control from one location to another.

2.2.6 At the navigating bridge, the control of the routine manoeuvres for one line of shafting is to be performed by a single control device: a lever, a handwheel or a push-button board. However each mechanism contributing directly to the propulsion, such as the engine, clutch, automatic brake or controllable pitch propeller, is to be able to be individually controlled, either locally or at a central monitoring and control position in the engine room.

2.2.7 Remote starting of the propulsion machinery is to be automatically inhibited if a condition exists which may damage the machinery, e.g. shaft turning gear engaged, drop of lubrication oil pressure or brake engaged.

2.2.8 As a general rule, the navigating bridge panels are not to be overloaded by alarms and indications which are not required.

2.2.9 At each control location there is to be an indicator showing which location is in control of propulsion machinery.

2.3 Automatic control

2.3.1 The requirements in Pt C, Ch 3, Sec 2, [3] of the Rules for the Classification of Ships apply. In addition, the following requirements are to be considered, when relevant.

2.3.2 Main turbine propulsion machinery and, where applicable, main internal combustion propulsion machinery and auxiliary machinery are to be provided with automatic shutoff arrangements in the case of failures such as lubricating oil supply failure which could lead rapidly to complete breakdown, serious damage or explosion.

2.3.3 The automatic control system is to be designed on a fail safe basis, and, in the event of failure, the system is to be adjusted automatically to a predetermined safe state.

2.3.4 When the remote control system of the propulsion machinery includes automatic starting, the number of automatic consecutive attempts is to be limited at a preset value of the starting air pressure permitting 3 attempts, and an alarm is to be provided, on the navigation bridge and in the machinery space.

2.3.5 Operations following any setting of the bridge control device (including reversing from the maximum ahead service speed in case of emergency) are to take place in an automatic sequence and with acceptable time intervals, as prescribed by the manufacturer.

2.3.6 For steam turbines, a slow turning device is to be provided which operates automatically if the turbine is

stopped longer than admissible. Discontinuation of this automatic turning from the bridge is to be possible.

2.4 Automatic control of propulsion and manoeuvring units

2.4.1 When the power source actuating the automatic control of propelling units fails, an alarm is to be triggered. In such case, the preset direction of thrust is to be maintained long enough to allow the intervention of engineers. Failing this, minimum arrangements, such as stopping of the shaft line, are to be provided to prevent any unexpected reverse of the thrust. Such stopping may be automatic or ordered by the operator, following an appropriate indication.

2.5 Clutches

2.5.1 Where the clutch of a propulsion engine is operated electrically, pneumatically or hydraulically, an alarm is to be given at the control station in the event of loss of energy; as far as practicable, this alarm is to be triggered while it is still possible to operate the equipment.

2.5.2 When only one clutch is installed, its control is to be fail-set. Other arrangements may be considered in relation to the configuration of the propulsion machinery.

2.6 Brakes

2.6.1 Automatic or remote controlled braking is to be possible only if:

- propulsion power has been shut off
- the turning gear is disconnected
- the shaftline speed (r.p.m.) is below the threshold stated by the builder.

SECTION 8

SAFETY SYSTEMS AND FIRE PROTECTION, DETECTION AND EXTINCTION

1 General

1.1 Purpose and application

1.1.1 The requirements of this Section apply to MODU units in addition to those contained in Part C, Chapter 4 of these Rules.

2 Fire and gas detection

2.1 Areas to be protected

2.1.1 Fixed automatic combustible gas detection and alarm systems are to be provided for the following areas:

- a) Cellar deck
- b) Drill floor
- c) Mud pit area
- d) Shale shaker area
- e) Enclosed spaces containing the open components of mud circulation system from the bell nipple to the mud pits.

3 Emergency shut down system

3.1 Documents to be submitted

3.1.1 The following documentation is to be sent for approval:

- a) diagram of emergency shutdown system
- b) cause and effects diagram.

3.2 Emergency conditions due to drilling operations

3.2.1 In view of exceptional conditions, such as the well blow-out, in which the explosion hazard may extend outside the above-mentioned zones, special arrangements are to be provided to facilitate the selective disconnection or shutdown of:

- ventilation systems, except fans necessary for supplying combustion air to prime movers for the production of electrical power;
- main generator prime movers, including the ventilation systems for these;
- emergency generator prime movers.

3.2.2 Disconnection or shutdown is to be possible from at least two strategic locations, one of which is to be outside hazardous areas.

3.2.3 Shutdown systems that are provided to comply with [3.2] are to be so designed that the risk of unintentional stoppages caused by malfunction in a shutdown system and the risk of inadvertent operation of a shutdown are minimized.

3.2.4 Equipment which is located in spaces other than enclosed spaces and which is capable of operation after shutdown as given in [3.2.1] are to be suitable for installation in Zone 2 locations. Such equipment which is located in enclosed spaces should be suitable for its intended application to the satisfaction of the Society. At least the following facilities are to be operable after an emergency shutdown:

- emergency lighting for half an hour;
- blow-out preventer control system;
- general alarm system;
- public address system; and
- battery supplied radio communication installations.

4 Fire protection, detection and extinction

4.1 Emergency control stations

4.1.1 At least two emergency control stations are to be provided. One of the stations is to be located near the drilling console and the second station is to be at a suitable manned location outside the hazardous areas.

4.1.2 The control stations are to be provided with:

- Manually operated contact makers for actuating the general alarm system.
- An efficient means of communication between these stations and all locations vital to the safety of the unit.
- Emergency shut-down facilities.

APPENDIX 1

IMPACT LOADS AND VORTEX SHEDDING

1 General

1.1 Application

1.1.1 Structural members of the unit located within the zone subject to wave slamming are to be checked taking account of forces caused by the above wave slamming against their surface.

1.2 Wave slamming against horizontal members

1.2.1 The slamming force may be calculated with the following equation:

$$\vec{F}_s = \frac{1}{2} \cdot \rho \cdot C_s \cdot A \cdot |\vec{v}_p| \cdot \vec{v}_p$$

where:

- F_s : slamming force per unit length of the member, in N/m;
- ρ : mass density of water, in kg/m³;
- C_s : slamming coefficient;
- A : area, in profile view, (normal to the direction of the velocity of wave surface \vec{v}_p) of the member per unit length of the latter in m²/m;
- v_p : velocity or wave surface normal to the surface of the member, in m/s,

The slamming coefficient C_s may be determined by means of theoretical or experimental methods.

For circular cylindrical members the value of C_s may be assumed equal to π in the absence of oscillations of the member concerned.

In the case of resonance between the natural frequency of the member and that of the exciting wave, the value of C_s is to be increased up to twice.

The wave slamming is also to be considered in the fatigue analysis. An applicable procedure for evaluating fatigue effects is outlined in App 2.

1.3 Impact from breaking waves

1.3.1 Vertical members are not exposed to wave slamming but may be subject to shock pressure from breaking waves

The shock pressure per unit length of the member may be determined according to [1.2.1] and may be applied to a member length equal to 1/4 of the wave height H in N years.

Depending on the value of such pressure, in addition to the global effect on the member and on the unit, the effect of the local pressure p is to be considered. For circular cylindrical members, the local pressure p , to be taken for the local check, may be determined as shown in Fig 1.

The value of the impact velocity is given by the maximum horizontal velocity or water particles of a wave having height H and such a period as to break in correspondence of the actual water depth (see Sec 2, Fig 1).

The region to be investigated is that from the still water level to the wave crest.

Figure 1

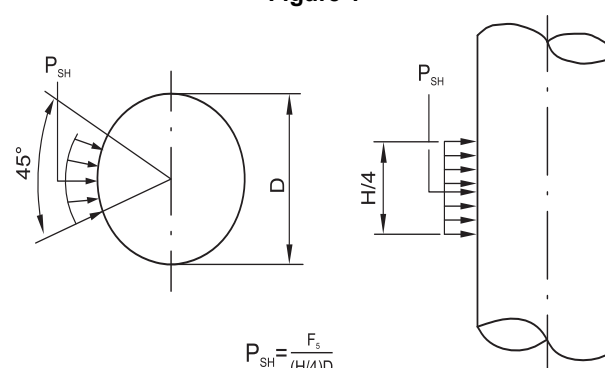

2 Vortex shedding

2.1 General

2.1.1 Wind, waves and current flow past a structural member may cause unsteady flow patterns due to vortex shedding which may lead to flexural vibrations of the member. This phenomenon may be dangerous when the vortex shedding frequency coincides with or is a multiple of the natural frequency of the member.

The vortex shedding frequency may be calculated with the following equation:

$$f_v = \frac{St \cdot v}{D}$$

where:

- f_v : vortex shedding frequency, in s⁻¹;
- St : Strouhal number;
- v : flow velocity normal to the member axis, in m/s;
- D : diameter (or equivalent dimension for non-circular cross-sectional shape members) of the member, in m.

The relationship between the Strouhal number St and the Reynolds number $Re = v \cdot D/\nu$, where ν is the kinematic viscosity of the fluid, in m²/s, for circular cylinder members, is given in Fig 2. The values of the Strouhal number St for sec-

tional shapes other than circular cylinders, as a function of the wind direction, are given in Tab 1.

As a first approach, the resonant vortex shedding due to wind, waves and current flow are to be considered when the condition given in [2.2.1], [2.3.1] and [2.4.1] occur.

2.2 Vortex shedding due to wind

2.2.1

- a) Flexural resonant vibrations of the member in line with the flow velocity of the wind may occur when:

$$1,7 \leq v_r \leq 3,2$$

where:

v_r : $v / (f_i \cdot D)$ = reduced velocity, in m/s;

where:

f_i : natural frequencies of the member vibrating in line with the flow velocity of wind, in s^{-1} ;

v, D : as defined in [2.1];

- b) Cross flow flexural resonant vibrations of the member may occur when:

$$4,7 \leq v_r \leq 8,0$$

2.3 Vortex shedding due to steady current

2.3.1

- a) Flexural resonant vibrations of the member in line with the flow velocity of the current may occur when:

$$1,2 < v_r < 3,5$$

$$k_s < 1,2$$

where:

v_r, D : as defined in [2.1] and [2.2];

K_s : $m_e / (L \cdot \rho \cdot D^2)$ = stability parameter;

m_e : mass of the member per unit length, including the added mass, in kg/m;

ρ : mass density of water, in kg/m^3 .

- b) Cross flow flexural resonant vibrations of the member may occur when:

$$v_r \geq 3,5$$

$$k_s \geq 16$$

2.4 Vortex shedding due to waves

- 2.4.1** Flexural resonant vibrations of the member with in line or cross flow excitation may occur when:

$$v_r \geq 1,0$$

$$KC \geq 3,0$$

where:

v_r : as defined in [2.2];

KC : $(v_m \cdot T) / D$ = Keulegan-Carpenter number;

v_m : maximum orbital velocity of fluid particles, in m/s;

T : wave period, in s;

D : as defined in [2.1];

2.5 Vortex shedding induced forces

- 2.5.1** Vortex shedding induced forces may be calculated with the following equation:

$$F = \pm 0,5 \cdot \rho \cdot C_f \cdot D \cdot v^2$$

where:

F : force per unit length of the member, in N/m;

ρ, D : as defined in [2.1], [2.2] and [2.3];

C_f : fluctuating force coefficient;

v : flow velocity of fluid normal to the axis of the member, in m/s.

The values of the coefficient C_f may be found from the existing literature or from model tests and are in any case subject to approval by the Society. Figures 3 and 4 may be used as guidance for determining the transverse and in line fluctuating force coefficients C_f for smooth circular cylindrical members.

The value of the force calculated with equation above shall be increased when resonant vibrations of structural members are likely to occur (see [2.2], [2.3] and [2.4]), multiplying the above value by a dynamic amplification factor AD given by the following equation:









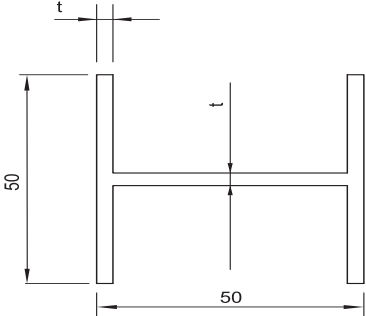

$$AD = \frac{1}{2\xi} \cdot (1 - e^{-2\pi n\xi})$$

where:

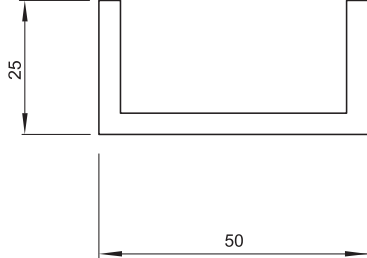
ξ : damping ratio, which may be taken equal to 0,005 for welded steel structures in air and equal to 0,02 for welded steel structures in water;

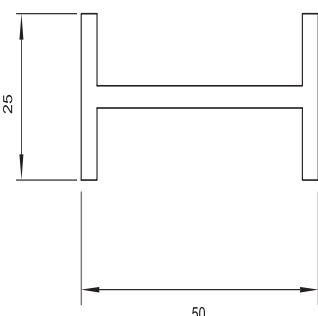
n : number of load cycles, which may be taken as infinite, if vortex shedding due to wind or steady current is considered; if vortex shedding due to waves is considered, n is the number of complete load cycles, in the time interval of half a wave period where the orbital velocity component normal to the axis of the member is within the range which can cause resonant vortex shedding.

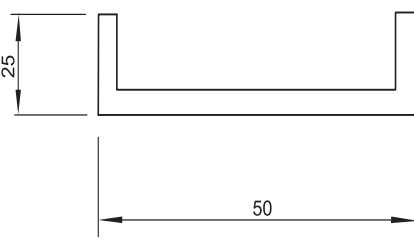
Table 1 : Strouhal number for members of various cross-sectional shapes

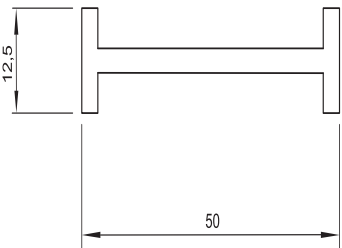
Wind	Profile dimensions in mm	St	Wind	Profile dimensions in mm	St
 	 <p>t = 2,0</p>	 0,120 	 <p>t = 1,0</p>	0,140 0,153	
					
	 <p>t = 1,0</p>	 0,144 	 <p>t = 1,0</p>	0,156 0,145	
					 <p>t = 1,5</p>

Wind	Profile dimensions in mm	St	Wind	Profile dimensions in mm	St
		0,147		0,121	
				0,143	
		0,150		0,135	
←		0,145		0,160	
↕		0,142			
↘		0,147			
←		0,131		0,114	
↕		0,134		0,145	
↘		0,137			

Figure 2 : Strouhal number for smooth cylindrical members

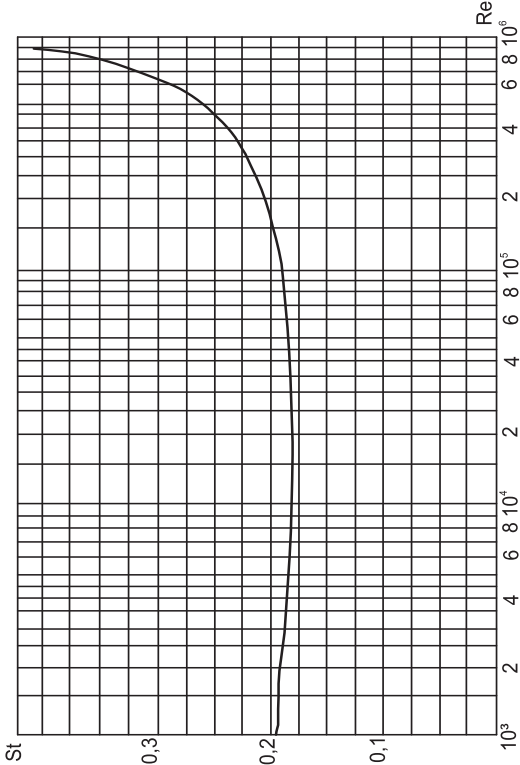

Figure 3 : Fluctuating in line force coefficient C_f for smooth cylindrical members

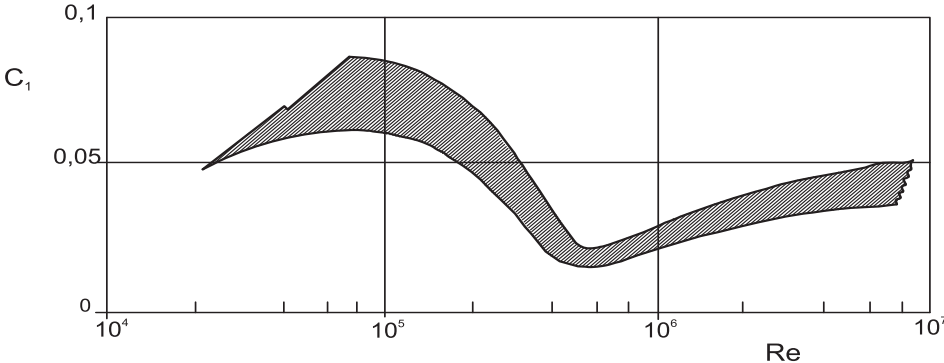
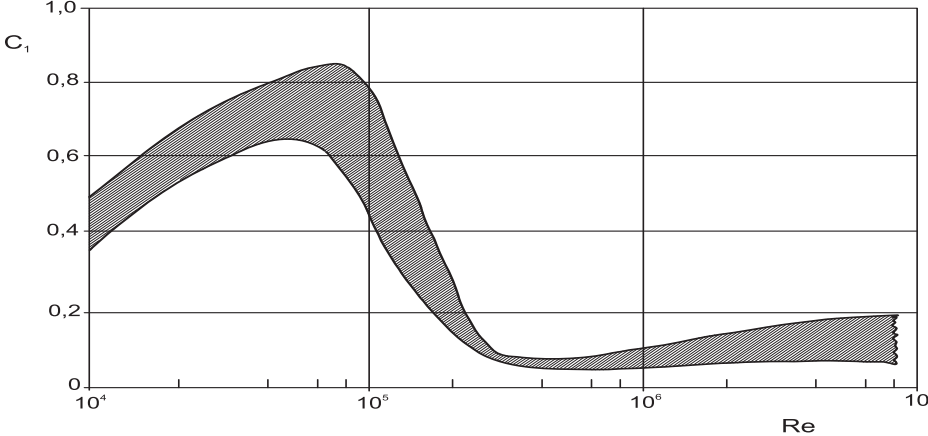

Figure 4 : Fluctuating cross-flow force coefficient C_f for smooth cylindrical members



APPENDIX 2

FATIGUE ANALYSIS WITH DETERMINATION OF THE CUMULATIVE DAMAGE

1 General

1.1 Application

1.1.1 This method includes the following steps:

- determination of long term distribution of stress range;
- selection of an appropriate fatigue curve (S-N curve);
- determination of the cumulative damage.

2 Determination of long term distribution of stress range

2.1

2.1.1 All stress fluctuations which during the entire life of the unit may cause damage due to fatigue are to be considered.

Such fluctuations may be caused by:

- direct and indirect (vortex shedding) actions of waves
- wind
- current
- operational loads
- machinery.

The wave induced forces are generally the main cause of damage to structures due to fatigue.

2.1.2 The effects of dynamic response of structures are to be properly accounted for, if significant; special care is to be taken to adequately determine the stress ranges in members excited in ranges close to resonance range.

2.1.3 As most of the loads which contribute to fatigue are of a random nature, the determination of the long term distribution of stress range may be performed either with spectral analysis or with deterministic analysis. Both the method of analysis and the relevant basic assumptions are subject to approval by the Society.

In the determination of the long term distribution of stress range, a sufficient number of combinations of environmental conditions (waves, wind and current) including their direction and associated probability of occurrence are to be taken into account.

2.1.4 In the case of structures with linear response to wave excitations and of wave height distribution according to the Rayleigh distribution, the long term distribution of stress range of each structural detail can be approximately described by a straight line joining in a semi-logarithmic diagram ($\log N$, $\Delta \sigma$) (see Fig 1), the point (0, $\Delta \sigma_{\max}$) with the point ($\log N_{\max}$, 0), where:

$\Delta \sigma_{\max}$: maximum stress range induced on the structural element concerned by a wave having a recurrence period equal to the life of the structure;

N_{\max} : number of wave cycles corresponding to the life of the structure.

3 Fatigue curve (S-N curve)

3.1

3.1.1 The fatigue strength of a structural element is normally given as an S-N curve, i.e. stress versus number of cycles to failure.

The above curve is to be applicable to the material employed, the constructional details, the mean stress level and environmental conditions considered and the corrosion protection system adopted.

3.1.2 In the case of an S-N curve which does not take into account stress concentrations due to the particular geometrical configuration of the structural element concerned, for the determination of the cumulative damage the nominal stress amplitudes, constituting the long term distribution, shall be multiplied by a suitable stress concentration factor. The values of stress concentration factors are to be obtained either from the existing technical literature or from sophisticated structural strength calculations of the element concerned or from model tests.

3.1.3 The S-N curves and the values of the stress concentration factors adopted are to be submitted to the Society for approval.

4 Determination of the cumulative damage

4.1

4.1.1 The cumulative damage due to fatigue may be determined according to the Palmgren-Miner method which implies that the long term distribution of stress range is replaced by a stress histogram consisting of an adequate number R of constant amplitude ($\Delta \sigma_i$) stress range blocks.

According to the above method, the cumulative damage ratio η is given by the following equation:

$$\eta = \sum_{i=1}^R n_i / N_i$$

where:

n_i : number of stress cycles in stress block i ;

N_i : number of cycles to fatigue failure at constant amplitude $\Delta\sigma_i$ stress range.

The number of stress blocks R is to be large enough to ensure reasonable numerical accuracy and in general is not to be less than 20.

4.1.2 Fig 2 schematically shows the procedure to be followed for the determination of the cumulative damage ratio η .

4.1.3 For horizontal structural members within the splash zone, the fatigue analysis is to include the contribution to fatigue from wave slamming, which may be evaluated according to the procedure shown in Fig 3, which implies the following steps:

- the minimum wave height H_{min} which can cause slamming is determined;
- the long term distribution of wave heights in excess of H_{min} , is divided into a reasonable number of blocks;
- for each block, the stress range is taken as:

$$\Delta\sigma_i = 2 [a \sigma_{imp} - (\sigma_b + \sigma_w)]$$

where:

σ_{imp} : stress in the member due to slam load;

σ_b : stress due to net buoyancy force on the member;

σ_w : stress due to vertical wave forces on the member;

a : dynamic amplification coefficient

$a = 1,5$ if the member end is considered;

$a = 2,0$ if the member mid-span is considered;

- each slam is associated with 20 linearly decaying stress ranges;

- the contribution to fatigue from each wave block η_j is calculated by the following equation:

$$\eta_j = F_r(n_j/N_j) \sum_{i=20-n_r}^{20} (i/20)^k$$

where:

n_j : number of waves within the block j ;

N_j : number of cycles to fatigue failure at constant stress amplitude $\Delta\sigma_j$;

n_r : number of cycles associated with the cut off level of the S-N curve;

F_r : reduction factor connected with the direction of wave origin. Assuming that a given member is only subject to impact from waves within a sector of 10° to each side of the perpendicular to the member axis, and assuming the direction of wave origin to be equiprobable, F_r has the following value:

$$F_r = (1/180) \cdot 20 \approx 0,11$$

K : slope of the S-N curve.

4.1.4 In the absence of a detailed analysis of the effects of combined fatigue due to simultaneous high frequency stress cycles from slamming and low frequency stress cycles from other loads, the contribution to fatigue due to slamming is to be added conservatively to the fatigue contribution of other variable loads mentioned in [4.1.1].

Figure 1

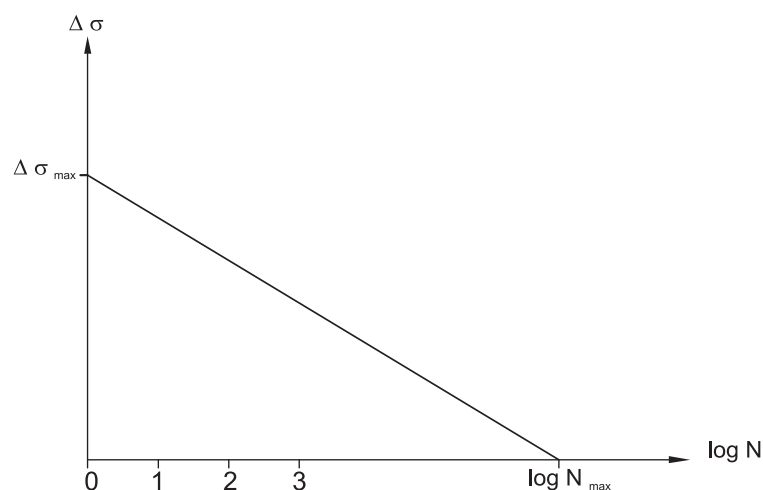

Figure 2

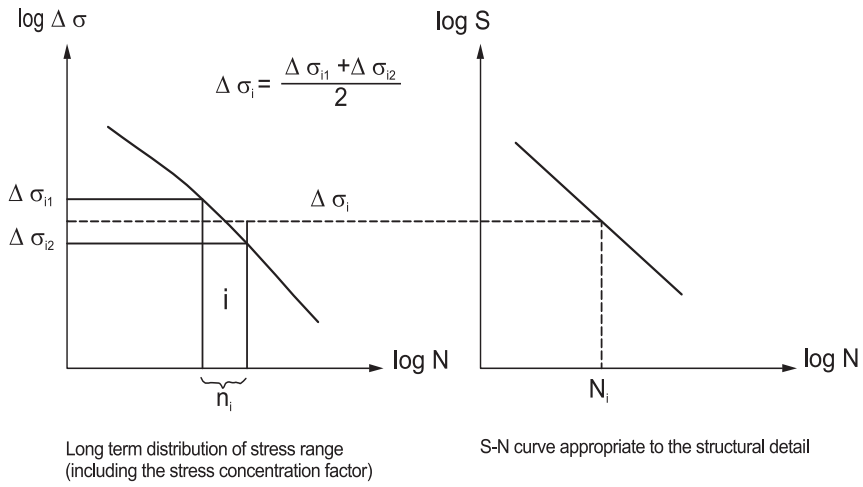
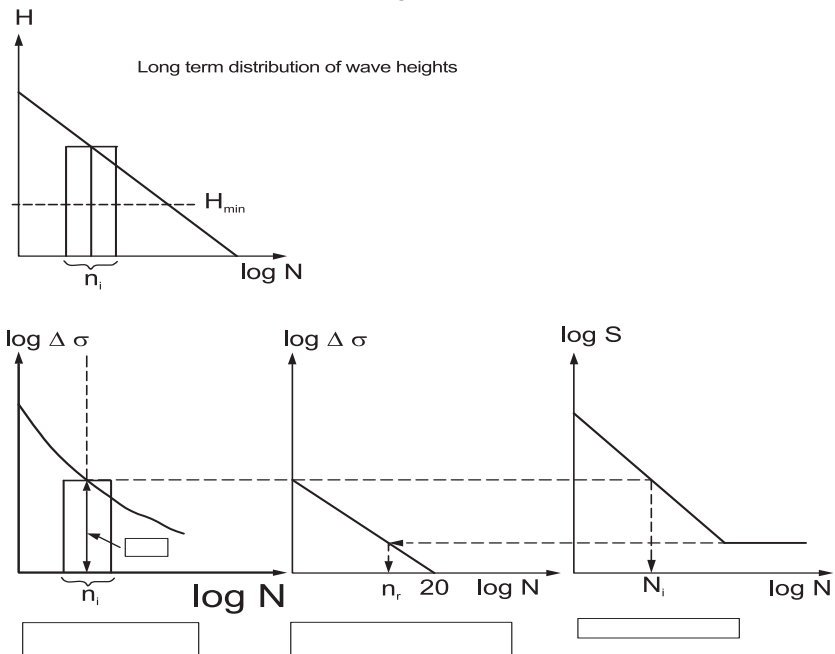

Figure 3



APPENDIX 3

AN EXAMPLE OF ALTERNATIVE CRITERIA FOR A RANGE OF POSITIVE STABILITY AFTER DAMAGE OR FLOODING FOR COLUMN-STABILIZED SEMI-SUBMERSIBLE UNITS

1 General

1.1 Application

1.1.1 The criteria hereunder constitute an alternative to those in item Sec 3, [5.2.1] c) and Sec 3, [5.2.2] c). These criteria apply only to column-stabilized semisubmersible units which have buoyant volumes contained in watertight upper-deck structure

1.1.2 The righting lever curve after damage or flooding, as set out in items Sec 3, [6.3] and in Sec 3, [5.2.2] respectively, is, before the second intercept angle, to reach a value of at least 2,5 m (see Fig 1). At least 1,0 m of this righting lever is to arise from enclosed watertight flats positioned at, or above, the lowest continuous deck.

1.1.3 The righting lever curve after damage or flooding, as set out in items Sec 3, [6.3] and in Sec 3, [5.2.2] respectively, is to have a positive range of at least 10° between the first and second intercept.

1.1.4 For the purposes of calculating the righting lever curve, buoyancy may be assumed from all spaces which are closed as described in items [1.1.5] and [1.1.6] below. If the lower edge of any opening which is not closed as required in items [1.1.5] and [1.1.6] is submerged, then the corresponding space is to be excluded from the buoyancy beyond the angle where this opening is submerged, but it to be included up to the angle where this opening is submerged. Any such loss of buoyancy is not to cause the righting lever to fall below 1,0 m above the wind heeling lever within the range specified in item [1.1.3].

1.1.5 Any opening submerged before the angle at which the righting lever required in item [1.1.3] is reached is to be fitted with a remotely operated watertight means of closure. Means of closure of a self activating type may also be accepted by the Society.

1.1.6 Any opening submerged after the angle referred to in item [1.1.5] is reached and within the range specified in item [1.1.3] is to be fitted with means of closure as required in item [1.1.5] or with easily operable weathertight means of closure.

Figure 1

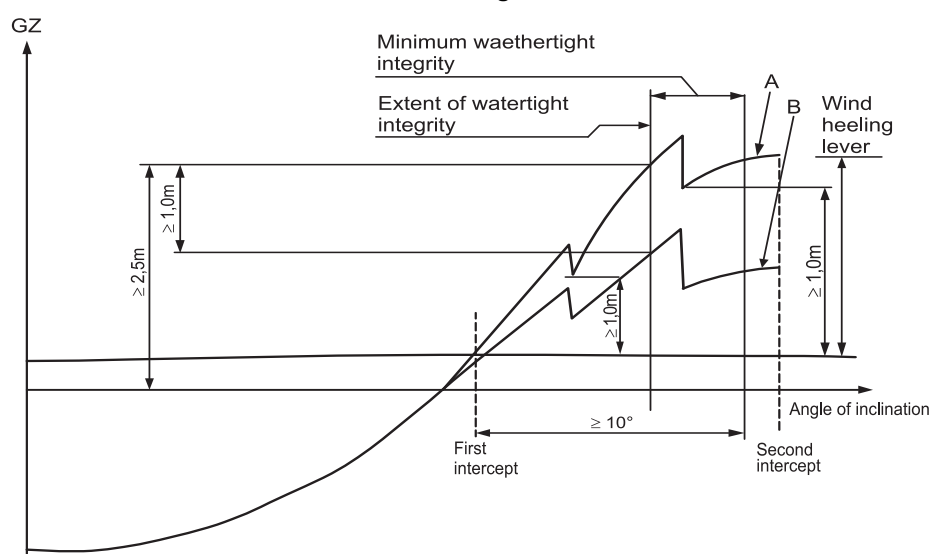

A - GZ-curve including enclosed volumes above watertight flats at or above the lowest continuous deck
 B - GZ-curve excluding enclosed volumes above watertight flats at or above the lowest continuous deck

APPENDIX 4

AN EXAMPLE OF ALTERNATIVE CRITERIA INTACT STABILITY CRITERIA FOR TWIN-PON- TOON COLUMN-STABILIZED SEMISUBMERSIBLE UNITS

1 General

1.1 Application

1.1.1 The criteria hereunder constitute alternative intact stability criteria for column-stabilized units under the provisions of item Sec 3, [4.1.3]. These criteria apply only to twin-pontoon column-stabilized semisubmersible units in severe storm conditions which fall within the following range of parameters:

V_p / V_T : is between 0,48 and 0,58

A_{WP} / V_C : is between 0,72 and 1,00

$I_{WP} / [V_C \cdot (L_{PTN/2})]$: is between 0,40 and 0,70 The parameters used in the above equations are defined in item [3].

2 Intact stability

2.1

2.1.1 The stability of a unit in the survival mode of operation should meet the following criteria:

a) Capsize criteria

These criteria are based on the wind heeling moment and righting moment curves, calculated as shown in item Sec 3, [3], at the survival draught. The reserve energy area B must be greater than 10% of the dynamic response area A as shown in Fig 1

$\text{Area B} / \text{Area A} > 0,10$

where:

- Area A is the area under the righting arm curve measured from θ_1 to $(\theta_1 + 1,15 \theta_{dyn})$
- Area B is the area under the righting arm curve measured from $(\theta_1 + 1,15 \theta_1)$ to θ_2
- θ_1 is the first intercept with the 100 knot wind moment curve
- θ_2 is the second intercept with the 100 knot wind moment curve
- θ_{dyn} is the dynamic response angle due to waves and fluctuating wind
 - $\theta_{dyn} = (10,3 + 17,8 C) / (1 + GM / (1,46 + 0,28 BM))$
 - $C = (L_{PTN}^{5/3} * VCP_{w1} * A_w * V_p * V_c^{1/3}) / (I_{WP}^{5/3} * VT)$

Parameters used in the above equations are defined in item [3].

b) Downflooding criteria

These criteria are based on the physical dimensions of the unit and the relative motion of the unit about a static inclination due to a 75 knot wind measured at the survival draught. The initial downflooding distance (DFD_0) must be greater than the reduction in downflooding distance at the survival draught as shown in Fig 2.

$DFD_0 - RDFD > 0,0$

where:

DFD_0 : initial downflooding distance to D_m in metres

$RDFD$: reduction in downflooding distance in metres = $SF (k \cdot QSD_1 + RMW)$

SF : 1,10, which is a safety factor to account for uncertainties in the analysis, such as non-linear effects

k : correlation factor = $0,55 + 0,08 (a - 4,0) + 0,056 (1,52 - GM)$

a : $(FBD_e / D_m) (S_{PTN} \cdot L_{CC}) / A_{WP}$
(a cannot be less than 4,0)
(GM cannot be greater than 2,44 m)

QSD_1 : DFD_0 - quasi-static downflooding distance at θ_1 , in metres, but not to be taken less than 3,0 m

RMW : relative motion due to waves about θ_1 , in metres = $9,3 + 0,11 (X - 12,19)$

X : $D_m (V_T / V_P) (A_{WP}^2 / I_{WP}) (L_{CC} / L_{PTN})$
(X cannot be taken to be less than 12,19 m)

The parameters used in the above equations are defined in item [3].

3 Geometric parameters

3.1

3.1.1

A_{WP} : is the waterplane area at the survival draught including the effects of bracing members as applicable, in m^2

A_w : is the effective wind area with the unit in the upright position (i.e. the product of projected area, shape coefficient and height coefficient), in m^2

BM : is the vertical distance from the metacentre to the centre of buoyancy with the unit in the upright position, in m is the initial survival draught, in m

D_m	: is the initial survival draught, in m	l_{CCC}	: is the longitudinal distance between centres of the corner columns, in m
FBD_0	: is the vertical distance from D_m to the top of the upper exposed weathertight deck at the side, in m	l_{PTN}	: is the length of each pontoon, in m
GM	: for item [2.1.1], GM is the metacentric height measured about the roll or diagonal axis, whichever gives the minimum restoring energy ratio B / A . This axis is usually the diagonal axis as it possesses a characteristically larger projected wind area which influences the three characteristic angles mentioned above	S_{PTN}	: is the transverse distance between the centre-line of the pontoons, in m
GM	: for item [2.1.2], GM is the metacentric height measured about the axis which gives the minimum downflooding distance margin (i.e. generally the direction that gives the largest QSD_1), in m	V_C	: is the total volume of all columns from the top of the pontoons to the top of the column structure, except for any volume included in the upper deck, in m^3
I_{WP}	: is the waterplane second moment of inertia at the survival draught including the effects of bracing members as applicable, in m^4	V_P	: is the total combined volume of both pontoons, in m^3
		V_T	: is the total volume of the structures (pontoons, columns and bracings) contributing to the buoyancy of the unit, from its baseline to the top of the column structure, except for any volume included in the upper deck, in m^3
		$V_{CP_{W1}}$: is the vertical centre of wind pressure above D_m in m

Figure 1 : Righting moment and heeling moment curves

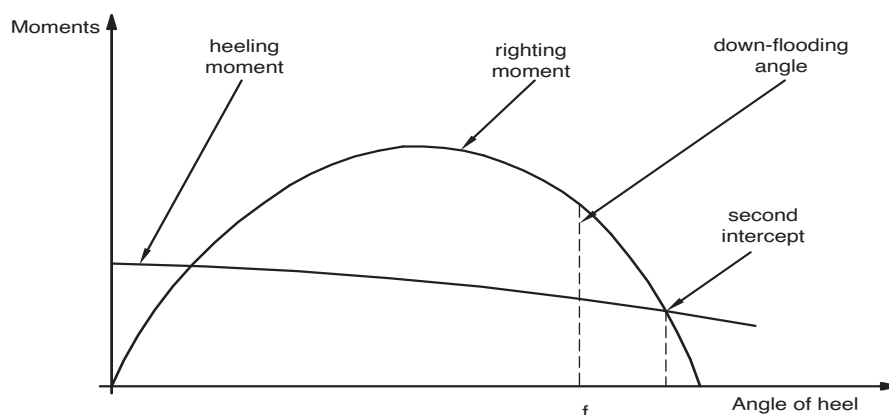

(+) > 1,4 1,3 (+)

Figure 2 : Definition of downflooding distance and relative motion

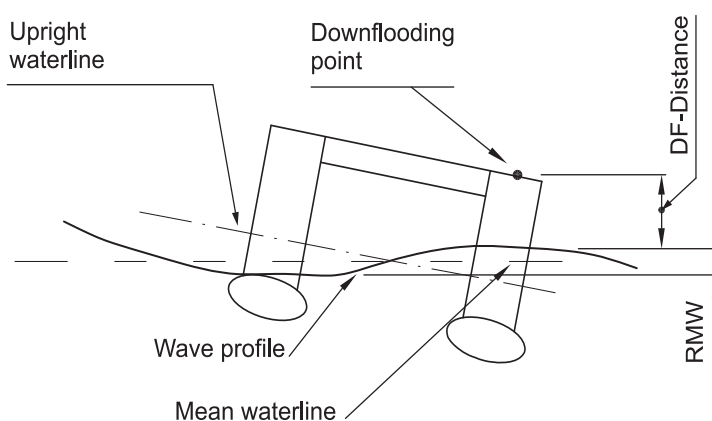

SECTION 1	GENERAL
SECTION 2	STABILITY
SECTION 3	UNIT ARRANGEMENT
SECTION 4	CARGO CONTAINMENT
SECTION 5	LIQUEFACTION PROCESS SYSTEMS, PROCESS PRESSURE VESSELS AND LIQUID, VAPOUR AND PRESSURE PIPING SYSTEMS
SECTION 6	MATERIALS FOR CONSTRUCTION
SECTION 7	CARGO PRESSURE/TEMPERATURE CONTROL
SECTION 8	CARGO TANK AND PROCESS VENTING SYSTEM
SECTION 9	ENVIRONMENTAL CONTROL
SECTION 10	ELECTRICAL INSTALLATIONS
SECTION 11	SAFETY SYSTEM AND FIRE PROTECTION
SECTION 12	MECHANICAL VENTILATION IN THE CARGO AREA
SECTION 13	INSTRUMENTATION (GAUGING, GAS DETECTION)
SECTION 14	PROTECTION OF PERSONNEL
SECTION 15	FILLING LIMITS FOR CARGO TANKS
SECTION 16	USE OF CARGO AS FUEL

SECTION 17 SPECIAL REQUIREMENTS

SECTION 1 GENERAL

1 Scope

1.1 Application

1.1.1 IGC Code requirements, Society's Rules and other Standards

- a) The design of an FLNG unit brings together established methods from onshore LNG plants and FPSOs but includes several unique elements due to the complexity of the liquefaction system, the cryogenic equipment, the large utility consumption (notably cooling water and possibly the electrical supply system) and the handling LNG or other hazardous products in a relatively confined space.
- b) These units, where liquefied gases are produced, piped to storage, stored within a containment system and ultimately transferred within and off the unit, are to comply with the requirements of the latest version of the International Code for the Construction and Equipment of Ships Carrying Liquefied Gases in Bulk, as amended. In these Rules reference to this Code and its amendments is made by the wording "IGC Code".

Accordingly, for units for which the service notation **FLNG** is requested, in accordance with Pt A, Ch 1, Sec 2, [4.6], , the IGC Code requirements are to be considered as Rule requirements, with the exception indicated in [1.1.5].

- c) Furthermore, these units are to comply with the requirements of the flag State and the national authorities covering the waters where they are located. Compliance with the prescribed national standards is to be demonstrated by the issue of appropriate certificates either by such authorities or by Tasneef if authorised.
- d) The requirements of this Chapter supplement those of the IGC Code, as amended. These requirements include additional mandatory class requirements, as well as the Society's interpretations of the IGC Code, which are also to be considered mandatory for class.
- e) This Chapter and the IGC Code refer to units producing, handling and storing those products which are listed in the table in Chapter 19 of the IGC Code and in Section 19 of this Chapter, as applicable to FLNG.
- f) This Chapter and the IGC Code include requirements for the storage of LNG in containment systems incorporating integral, membrane or independent tank types as detailed in Chapter 4 of the IGC Code and in Sec 4.
- g) In general, this Chapter applies to cargo containment and handling systems and to the interfaces between these systems and the remainder of the unit, which is to comply with the applicable Sections of the hull and machinery Rules.
- h) Additionally, light liquid hydrocarbons (condensate) separated from the feed gas are to be stored in dedicated tanks under an inert gas blanket, if required. The

handling and storage requirements for these liquids are dealt with in Part E, Ch 1 of these Rules.

1.1.2 Marinization

The technology of the process plants falls under the already accepted industrially recognised standards for onshore LNG plants and offshore process plants as specified in Section 17. However, the novel aspects due to the marinisation of these processes and the management of the interfaces of the topsides with the hull require ad hoc considerations, based on risk analysis, engineering studies, tests or other activities as needed, which are to be class approved.

1.1.3 Risk Analysis

The design of an FNLG installation is to include a Risk Analysis in accordance with Part C, Ch 7 of these Rules (which may be a part of the safety case as required by many national authorities), which may suggest additional requirements, interpretations of the standards to apply or equivalent design solutions can be adopted upon class approval.

1.1.4 Scope of classification

The scope of classification is in Pt A, Ch 1, Sec 1.

1.1.5 IGC Code requirements not within the scope of classification

The following requirements of the IGC Code are not within the scope of classification:

- Chapter 1, Section 1.4 - Equivalents
- Chapter 1, Section 1.5 - Surveys and certification
- Chapter 2, Section 2.4 - Condition of loading
- Chapter 2, Section 2.5 - Damage assumption
- Chapter 2, Section 2.7 - Flooding assumption
- Chapter 2, Section 2.8 - Standard of damage
- Chapter 2, Section 2.9 - Survival requirements
- Chapter 11 - Fire protection and fire extinction
- Chapter 14 - Personnel protection
- Chapter 18 - Operating requirements.

These requirements are applied by the Society when acting on behalf of the flag Administration, within the scope of delegation.

1.1.6 Storage of products not listed in the Code

The requirements of the IGC Code and the additional requirements of this Chapter are also applicable to new products, which may be considered to come within the scope of these Rules, but are not at present listed in the table in Chapter 19 of the IGC Code.

1.1.7 Particularly hazardous products For the storage in bulk of products which are not listed in the table in Chapter 19 of the IGC Code, presenting more severe hazards than those covered by the IGC Code, the Society reserves the right to establish requirements and/or conditions additional to those contained in these Rules.

1.1.8 Correspondence of the IGC Code with this Chapter

All the requirements of this Chapter are cross referenced to the applicable Chapters, Sections or paragraphs of the IGC Code, as appropriate.

1.1.9 Equivalencies

As far as the requirements for class are concerned, the following wording in the IGC Code is to be given the meanings indicated in Tab 1.

Table 1

IGC Code word	Meaning for Classification only
Administration	Society
Recognised Standard	Rules
should be	is to be or are to be (as applicable)

2 Documentation to be submitted

2.1

2.1.1

Tab 2 lists the plans, information, analysis, etc. which are to be submitted in addition to the information required in the other Parts of the Rules for the parts of the unit not affected by the cargo, as applicable.

Table 2 : Documents to be submitted

No	A/I	Documents
1	I	List of products and fluids required to be handled and stored, including maximum vapour pressure, maximum and minimum liquid temperatures and other important properties.
2	I	General arrangement plan, showing location of cargo tanks and fuel oil, ballast and other tanks
3	A	Gas-dangerous zones plan
4	A	Location of void spaces and accesses to dangerous zones
5	A	Air-locks between safe and dangerous zones
6	A	Ventilation duct arrangement in gas-dangerous spaces and adjacent zones
7	A	Details of hull structure in way of cargo tanks and process modules, including support arrangement for process equipment, cargo tanks, saddles, anti-floating and anti-lifting devices, deck sealing arrangements, etc.
8	A	Calculation of the hull temperature in all the design cargo conditions
9	A	Distribution of quality and steel grades in relation to the contemplated actual temperature obtained by the calculation in item 8
10	A	Hull stress analysis to include all possible tank loading conditions and process operating conditions
11	A	Hull unit motion analysis, where a direct analysis is preferred to the methods indicated in Sec 4
12	A	Intact and damage stability calculations
13	A	Scantlings, material and arrangement of the cargo containment system, including the secondary barrier, if any.
14	A	Stress analysis of the cargo tanks, including fatigue analysis and crack propagation analysis for type "B" tanks. This analysis may be integrated with that indicated in item 10
<p>Note 1: A = to be submitted for approval in four copies I = to be submitted for information in duplicate</p>		

3 Cargo equipment trials

3.1 Scope

3.1.1 Trials in working conditions

All the equipment to which this Chapter is applicable is to be tested in actual working conditions. See also Sec 4, [13.4].

3.1.2 Trials to be carried out

Those trials which may only be carried out when the unit is loaded are to be held at the first operation of the unit.

3.1.3 Testing at Manufacturer's

Where possible, cargo and process equipment is to be tested at the Manufacturer's worksite and under the conditions that the equipment will be expected to operate at when in service. For equipment that will be operated under cryogenic (less than -55°C) conditions, all testing is to be carried out under those conditions.

3.2 Extent of the tests

3.2.1 Testing procedure

Production, handling and storing equipment testing procedure is to be submitted to the Society for review.

3.2.2 Use of cargo or feed gas as fuel The arrangements for using cargo or feed gas as fuel are to be subjected to a special testing procedure.

No	A/I	Documents
15	I	Calculation of the thermal insulation suitability, including boil-off rate and refrigeration plant capability, if any, cooling down and temperature gradients during loading and unloading operations
16	A	Details of insulation arrangements with regard to possibility of storage of a number of liquefied gases
17	A	Details of ladders, fittings and towers in tanks and relative stress analysis, if any
18	A	Details of tank domes and deck sealings
19	A	Plans and calculations of safety relief valves. Details of all flaring and venting arrangements.
20	A	Details of cargo handling and vapour system, including arrangements and details of piping and fitting
21	A	Details of cargo pumps and cargo compressors
22	A	Details of process pressure vessels and associated valves arrangements
23	A	Bilge and ballast system in cargo and process areas
24	A	Gas freeing system in cargo tanks including inert gas system
25	A	Details of interbarrier and insulation space drainage, inerting and pressurisation systems. Details of liquid detection method in these spaces
26	A	Ventilation system in cargo and process areas
27	A	Hull structure heating system, if any
28	A	Liquefaction process including handling of condensates and process liberated vapours and details of all refrigerants involved
29	A	Documents giving details of type of cables and safety characteristics of the equipment installed in hazardous areas
30	A	Schematic electrical wiring diagram in cargo area
31	A	Fire and gas detection system
32	A	Cargo tank instrumentation, including cargo diagrams of tank level indicator systems, high level alarm systems and hull temperature monitoring system
33	A	Emergency shutdown system
34	A	Jettison system, if any
35	A	Details of fire-extinguishing appliances and systems in cargo and process areas
36	A	Loading and unloading operation description, including cargo tank filling limits
37	A	Cargo tank testing and inspection procedures
38	I	Documentation of Risk Analysis, engineering analyses and other activities required to demonstrate the acceptability of issues not explicitly covered by these Rules:
39		For machinery using gas as fuel: I a) General arrangement plan of the machinery plant I b) Description of the entire plant A c) Gas piping plans for the machinery plant A d) Complete list of the safety, gas detection and warning equipment A e) Drawings of the boilers I f) Detailed drawings of the gas inlet and fuel inlet equipment I g) Gas characteristics A h) General arrangement plan of the gas treatment plant, including gas compressors, prime movers and gas preheaters A i) Drawings of the gas storage tanks A j) Drawings of the gas compressors and preheaters
Note 1: A = to be submitted for approval in four copies I = to be submitted for information in duplicate		

SECTION 2

STABILITY

1 General

1.1

1.1.1

IGC CODE REFERENCE : Ch 2

This Section applies in addition to the requirements set out in Part B, Chapter 3.

2 Intact stability

2.1 General requirements

IGC CODE REFERENCE: Ch 2, 2.2.2

2.1.1

In each loading condition the following is to be satisfied:

- a) the initial metacentric height, calculated by taking into account the influence of the free surfaces, is to be not less than 0,15 m
- b) the diagrams of the stability arms are to confirm the following requisites:
 - 1) the arm of maximum stability G_{zmax} is to correspond to a transverse heeling angle preferably greater than 30° but in any case not less than 25° ;
 - 2) the arm of stability GZ is to be not less than 0,20 m with a transverse heeling angle θ not less than 30° ;
 - 3) the area below the stability diagram is to be not less than 0,055 m * rad for heeling angles θ from 0° to 30° and not less than 0,09 m * rad for heeling angles θ from 0° to 40° or to θ_f if the latter is less than 40° .

The heeling angle θ_f is that which corresponds to the intake of water and therefore defines where the stability curve is to be considered broken.

In addition to the above, the area below the stability diagram is to be not less than 0,030 m * rad, for heeling angles from 30° to 40° or from 30° to θ_f , if θ_f is less than 40° ;

- c) the provisions of the following paragraphs are to be checked in relation to the action of the wind.

2.1.2 Process Liquids

On FLNG plants there is a possibility that large volumes of fluids are stored either on the cargo deck or on the process decks. These volumes are to be taken into account in any stability calculations.

2.1.3 Process Vessels

The FLNG liquefaction process consists of a number of process vessels and fluid handling systems. These vessels will contain high volumes of fluids and the effect of these volumes is to be taken into account in stability calculations.

2.2 Weather criterion

IGC CODE REFERENCE : Ch 2, 2.2.2

2.2.1

The curves are to be traced of the righting and heeling moments due to the transverse wind similar to those shown in Fig 1, together with the relevant calculations, taking into account the maximum cargo on the deck and the equipment placed in the most unfavourable position. The effect of the free surfaces in the tanks is to be taken into account.

2.2.2

If there are structural fittings which can be dismantled and stowed, further curves of the heeling moment due to the wind may be requested and the relevant documentation is to clearly indicate the position of these fittings.

2.2.3

When calculating the righting moment, any possible negative effects due to the presence of the mooring system are to be taken into account.

2.2.4

As regards the calculation of the forces and heeling moment due to the wind, reference is made to the relevant provisions of Ch 4, Sec 3, [3.1] of these Rules.

In particular, for the wind speed, the characteristic value of the site corresponding to a recurring period of 100 years or the speed of 51,5 m/s (100 knots) is to be assumed, whichever is the greater.

For sites situated in protected zones, the Society reserves the right to accept a wind speed less than 51,5 m/s.

2.2.5

The stability of a unit is to satisfy the criteria stated under the following items (a) and (b) (see also Fig 1):

- a) The ratio of the area under the righting moment curve to that under the heeling moment curve up to the angle in way of the second intercept or up to the downflooding angle θ_f , whichever is the lesser, is to be not less than 1,4.
- b) The righting moment curve is to be positive over the entire range of angles up to the angle in way of the second intercept.

2.2.6

Each unit is to be capable of attaining a severe storm condition in a period of time consistent with the meteorological conditions. The procedures recommended and the approximate length of time required, considering both operating conditions and transit conditions, are to be contained in the Operating Manual.

It is to be possible to achieve the severe storm condition without the removal or relocation of solid consumables or other variable load.

However, the Society may permit loading a unit past the point at which solid consumables would have to be removed or relocated to attain the severe storm condition under the following conditions, provided the allowable KG requirement is not exceeded:

- a) in a geographic location where weather conditions annually or seasonally do not become sufficiently severe to require a unit to go to severe storm conditions, or
- b) where a unit is required to support extra deckload for a short period of time that falls well within a period for which the weather forecast is favourable.

The geographic locations, weather conditions and loading conditions in which this is permitted are to be identified in the Operating Manual.

2.3 Alternative stability criteria

IGC CODE REFERENCE : Ch 2, 2.2.2

2.3.1

Alternative stability criteria may be considered by the Society provided an equivalent level of safety is maintained and it is demonstrated that they afford adequate positive initial stability.

3 Location of cargo tanks and process equipment

3.1 Deck cargo tanks

3.1.1

IGC CODE REFERENCE : Ch 2, 2.6.1

Particular considerations are to be given to damage assumptions in way of sensitive areas, e.g. where process pipework or offloading systems are located, supported by Risk Analysis carried out in accordance with Pt C, Ch 7.

3.2 Oil tanks

3.2.1

Location of tanks used for the storage of liquid hydrocarbons (oil or condensate) is to comply with Pt E, Ch 1 of these Rules.

3.3 Process equipment

3.3.1

All process equipment is to be located within the confines of what is described as the process deck. The process deck may be the main cargo deck but in most cases will be a raised platform above the main cargo deck. The siting of the process is determined by the relevant offshore Rules as specified in Section 17. The location of the major items of process equipment is to be accounted for in all stability calculations.

Figure 1 : Righting moment and heeling moment curves

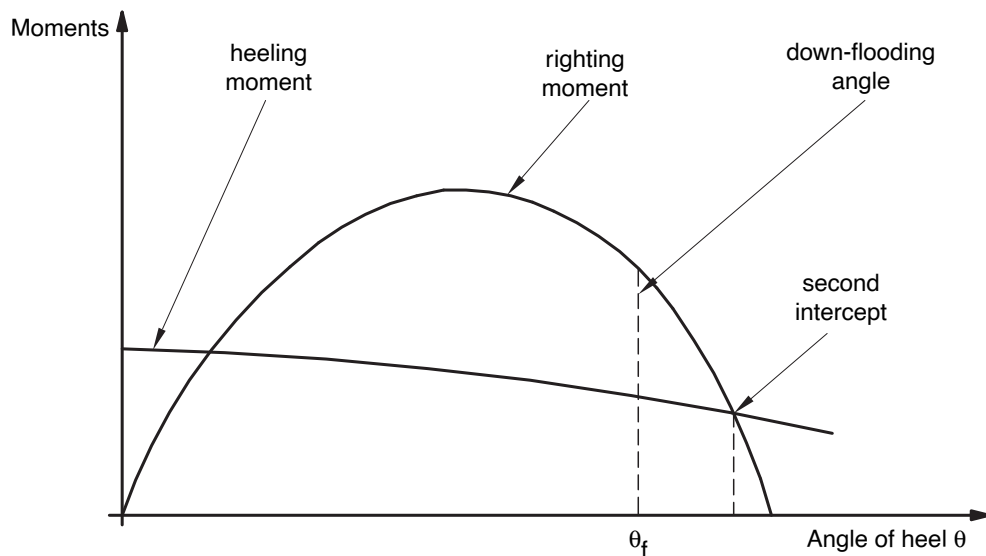

SECTION 3

UNIT ARRANGEMENT

1 Segregation of the cargo area

1.1 Segregation of hold spaces

1.1.1 Thruster location

IGC CODE REFERENCE : Ch 3, 3.1.1

Bow thrusters are allowed to be fitted forward of the hold spaces.

1.2 Cargo containment systems not requiring secondary barriers

1.2.1 Separation between cargo spaces)

IGC CODE REFERENCE : Ch 3, 3.1.2

Hold spaces may be separated from each other by single bulkheads. Where cofferdams are used instead of single bulkheads, they may be used as ballast tanks subject to special approval by the Society.

1.3 Cargo containment systems requiring secondary barriers

1.3.1 Separation between cargo spaces

IGC CODE REFERENCE : Ch 3, 3.1.3

The requirement in [1.2.1] is applicable.

1.4 Segregation of the Process Area

1.4.1

Machinery and equipment are to be arranged in groups in accordance with the recognised industry standard API RP14J and in accordance with Pt B, Ch 11, Sec 2, Pt C, Ch 6 and Pt E, Ch 2, Sec 2 of these Rules. Equipment items that could become fuel sources are to be separated from potential ignition sources by space separation, firewalls or protective walls. In case of a fire the means of escape is to permit the safe evacuation of all occupants to a safe area.

2 Accommodation, service and machinery spaces and control stations

2.1 General

2.1.1 Precautions against hazardous vapours

IGC CODE REFERENCE : Ch 3, 3.2.2

Compliance with the relevant requirements of the IGC Code, in particular with 3.2.4, 3.8, 8.2.10 and 12.1.6, as applicable, also ensures compliance with the requirements in IGC Code 3.2.2, relevant to precautions against hazardous vapours.

2.1.2 Spaces located forward of the cargo area

IGC CODE REFERENCE : Ch 3, 3.2.4

Entrances and openings to service spaces located forward of the cargo area may not face such area.

2.1.3 Air outlets

IGC CODE REFERENCE : Ch 3, 3.2.4

The requirements in IGC Code 3.2.4, relevant to air intakes, are also intended to be applicable to air outlets. This interpretation also applies to the requirements in IGC Code 3.2.2, 3.8.4 and 8.2.10.

2.1.4 Doors facing cargo area

IGC CODE REFERENCE : Ch 3, 3.2.4

Doors facing the cargo area or located in prohibited zones in the sides are to be restricted to stores for cargo-related and safety equipment, cargo control stations as well as decontamination showers and eye wash.

Where such doors are permitted, the space may not give access to other spaces covered in IGC Code 3.2.4 and the common boundaries with these spaces are to be insulated with A60 class bulkheads.

2.1.5 Exemptions, ventilation openings and type of closures

IGC CODE REFERENCE : Ch 3, 3.2.6

The requirement for fitting air intakes and openings with closing devices operable from inside the space in units intended to store toxic products is to apply to spaces which are used for the unit's radio and main navigating equipment, cabins, mess rooms, toilets, hospitals, galleys, etc., but does not apply to spaces not normally manned such as deck stores, forecastle stores and workshops. The requirement does not apply to cargo control rooms located within the cargo area.

When internal closing is required, this is to include both ventilation intakes and outlets.

The closing devices are to give a reasonable degree of gas-tightness. Ordinary steel fire-flaps without gaskets/seals are normally not considered satisfactory.

2.1.6 Openings for removal of machinery

IGC CODE REFERENCE : Ch 3, 3.2.6

Bolted plates of A60 class for removal of machinery may be accepted on bulkheads facing cargo areas, provided signboards are fitted to warn that these plates may only be opened when the unit is in gas-free condition.

3 Cargo pump rooms and cargo compressor rooms

3.1 Location of cargo pump rooms and cargo compressor rooms

3.1.1 Single failure concept

IGC CODE REFERENCE : Ch 3, 3.3

When cargo pump rooms and compressor rooms are permitted to be fitted at the after end of the aftermost hold space, the bulkhead which separates the cargo pump rooms or compressor rooms from accommodation and service spaces, control stations and machinery spaces of category A is to be so located as to avoid the entry of gas to these spaces through a single failure of a deck or bulkhead. The same condition is also to be satisfied when cargo pump rooms and compressor rooms fitted within the cargo area have a bulkhead in common with accommodation and service spaces, control stations and machinery spaces of category A.

3.1.2 Electrical equipment in cargo pump rooms and cargo compressor rooms

IGC CODE REFERENCE: Ch 3, 3.3

Cargo pump rooms and/or cargo compressor rooms of units storing flammable gases may not contain electrical equipment, except as provided for in Chapter 10 of the IGC Code, or other ignition sources such as internal combustion engines or steam engines with operating temperature which could cause ignition or explosion of mixtures of such gases, if any, with air.

4 Access arrangement

4.1 Access to compartments in the cargo area

4.1.1 General

IGC CODE REFERENCE : Ch 3, 3.5

Designated passageways below and above cargo tanks are to have at least the cross-sections as specified in IGC Code 3.5.3.1.

4.1.2 Passage through cargo tanks

IGC CODE REFERENCE : Ch 3, 3.5

For the purpose of the requirements in IGC Code 3.5.1 and 3.5.2, the following applies:

- Where the Surveyor needs to pass between the flat or curved surface to be inspected and structural elements such as deck beams, stiffeners, frames, girders etc., the distance between that surface and the free edge of the structural elements is to be at least 380 mm. The distance between the surface to be inspected and the surface to which the above structural elements are fitted, e.g. deck, bulkhead or shell, is to be at least 450 mm in the case of a curved tank surface (e.g. type C-tank) or

600 mm in the case of a flat tank surface (e.g. type A-tank) (see Fig 1).

Figure 1 : Minimum passage over cargo tanks

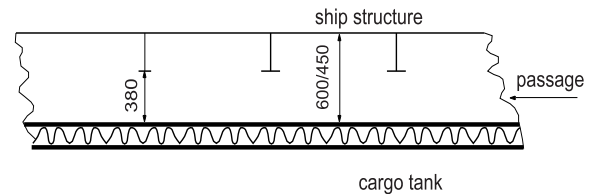

- Where the Surveyor does not need to pass between the surface to be inspected and any part of the structure, for visibility reasons the distance between the free edge of that structural element and the surface to be inspected is to be at least 50 mm or half the breadth of the structure's face plate, whichever is the greater (see Fig 2).

Figure 2 : Minimum distance of structures from cargo tank to allow visual inspection

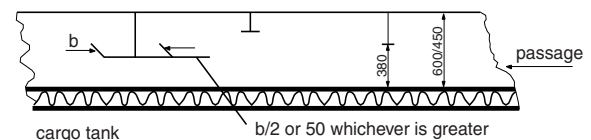

- If for inspection of a curved surface the Surveyor needs to pass between that surface and another flat or curved surface, to which no structural elements are fitted, the distance between both surfaces is to be at least 380 mm (see Fig 3). Where the Surveyor does not need to pass between a curved surface and another surface, a smaller distance than 380 mm may be accepted taking into account the shape of the curved surface.
- If for inspection of an approximately flat surface the Surveyor needs to pass between two approximately flat and approximately parallel surfaces, to which no structural elements are fitted, the distance between those surfaces is to be at least 600 mm (see Fig 4).
- The minimum distances between a cargo tank sump and adjacent double bottom structure in way of a suction well may not be less than that defined in Fig 5. If there is no suction well, the distance between the cargo tank sump and the inner bottom may not be less than 50 mm.
- The distance between a cargo tank dome and deck structures may not be less than 150 mm (see Fig 6).
- Where necessary for inspection, fixed or portable staging is to be installed. This staging may not impair the distances specified in IGC Code 3.5.3.
- Where fixed or portable ventilation ducting is to be fitted in compliance with IGC Code 12.2, such ducting may not impair the distances specified in IGC Code 3.5.3.

Figure 3 : Minimum passage between curved surfaces

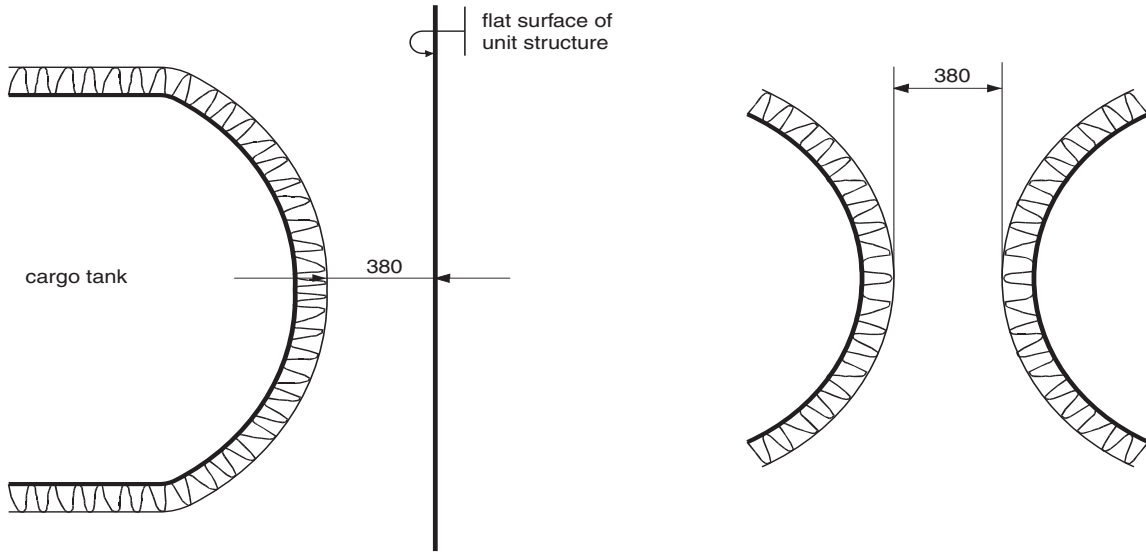

Figure 4 : Minimum passage between flat surfaces

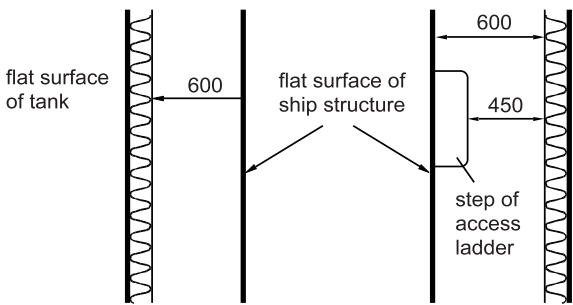

Figure 5 : Minimum distance of cargo tank sump and inner bottom

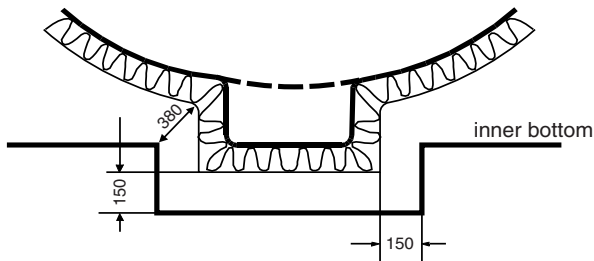
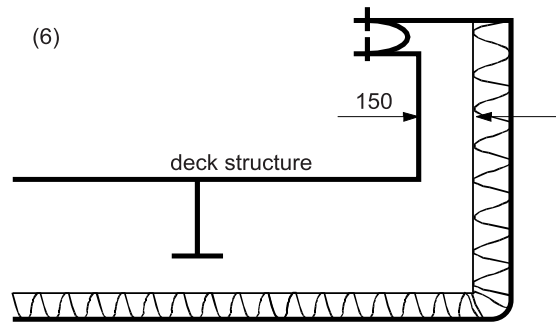

Figure 6 : Minimum distance between cargo dome and deck structures



4.1.3 Passage through hatches and manholes

IGC CODE REFERENCE : Ch 3, 3.5

For the purpose of the requirements in IGC Code 3.5.3, the following applies:

- a) The term "minimum clear opening of not less than 600 x 600 mm" means that such openings may have corner radii up to a maximum of 100 mm (see Fig 7).

Figure 7 : Minimum horizontal hatch size

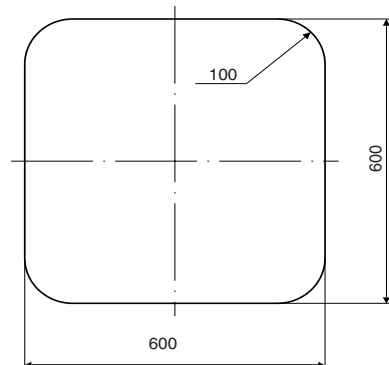

- b) The term “minimum clear opening of not less than 600 x 800 mm” also includes an opening of the size specified in Fig 8:

Figure 8 : Minimum size of manholes

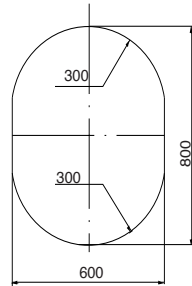

- c) Circular access openings in type C cargo tanks are to have diameters of not less than 600 mm.

4.1.4 Cofferdams

IGC CODE REFERENCE : Ch 3, 3.5

Where fitted, cofferdams are to have sufficient size for easy access to all their parts. The width of the cofferdams may not be less than 600 mm.

4.1.5 Pipe tunnels

IGC CODE REFERENCE : Ch 3, 3.5

Pipe tunnels are to have enough space to permit inspection of pipes. The pipes in pipe tunnels are to be installed as high as possible from the unit's bottom.

5 Air-locks

5.1 Arrangement

5.1.1

IGC CODE REFERENCE : Ch 3, 3.6.1

Air-locks are to be such as to provide easy passage and are to cover a deck area of not less than 1,5 m². Air-locks are to be kept unobstructed and may not be employed for other uses, such as storage.

5.2 Alarm

5.2.1 Alarm signalling lamp

IGC CODE REFERENCE : Ch 3, 3.6.3

The alarm systems are to be of the intrinsically safe type. However, signalling lamps may be of a safe type authorised for the dangerous spaces in which they are installed.

5.3 Electrical equipment

5.3.1 Acceptable alternatives to differential pressure

IGC CODE REFERENCE : Ch 3, 3.6.4

The following means are considered acceptable alternatives to differential pressure sensing devices in spaces having a ventilation rate not less than 30 air changes per hour:

- monitoring of current or power in the electrical supply to the ventilation motors; or
- air flow sensors in the ventilation ducts.

In spaces where the ventilation rate is less than 30 air changes per hour and where one of the above alternatives is fitted, in addition to the alarms required in IGC Code 3.6.3, arrangements are to be made to de-energise electrical equipment which is not of the certified safe type if more than one air-lock door is moved from the closed position.

5.4 Ventilation

5.4.1 Air changes

IGC CODE REFERENCE : Ch 3, 3.6.5

The spaces protected by air-locks are to be ventilated for the time necessary to give at least 10 air changes prior to energising the non-safe type electrical installations.

6 Bilge, ballast and fuel oil arrangements

6.1 Drainage arrangement

6.1.1 Drainage of dry spaces in the cargo area

IGC CODE REFERENCE : Ch 3, 3.7

Dry spaces within the cargo area are to be fitted with a bilge or drain arrangement not connected to the machinery space.

Spaces not accessible at all times are to be fitted with sounding arrangements.

Spaces without a permanent ventilation system are to be fitted with a pressure/vacuum relief system or with air pipes.

6.2 Additional requirements relative to the bilge system

6.2.1 Operation of the bilge system in cargo and interbarrier spaces

IGC CODE REFERENCE : Ch 3, 3.7

Bilge arrangements for holds containing cargo tanks and for interbarrier spaces are to be operable from the weather deck.

6.2.2 Means for leakage detection

IGC CODE REFERENCE : Ch 3, 3.7

With reference to the means to ascertain leakages in holds and/or in interbarrier spaces, the following requirements apply:

- the above-mentioned means is to be suitable to ascertain the presence of water:
 - in holds containing type C independent tanks
 - in holds and interbarrier spaces outside the secondary barrier

- the above-mentioned means is to be suitable to ascertain the presence of liquid cargo in the spaces adjacent to cargo tanks which are not type C independent tanks.

Where the aforesaid spaces may be affected by water leakages from the adjacent unit structures, the means is also to be suitable to ascertain the presence of water.

Where the above-mentioned means is constituted by electrical level switches, the relevant circuits are to be of the intrinsically safe type and signals are to be transduced to the cargo control room.

7 Bow or stern loading and unloading arrangements

7.1 Locations of stopping devices for cargo pumps and compressors

7.1.1

IGC CODE REFERENCE : Ch 3, 3.8.7

The safety criteria for this area are to be obtained by risk-based considerations (Pt C, Ch 7), taking into account the

whole process of loading, treatment, liquefaction and off-loading in normal and emergency conditions, with particular care to the interfaces.

8 Location of cargo control rooms

8.1 Location of cargo control rooms

8.1.1

Cargo control rooms are to be located as stated in the IGC Code Ch 3, 3.4

When cargo control rooms are situated in the area of a particular operational process, for example an offloading station local control room, that space is to comply with all the conditions for a cargo control room located in a hazardous area. Additional safety criteria for these areas are to take into account the issues of operation, safe shelter and escape of the personnel expected to be present in normal and emergency conditions, by means of risk-based considerations (Pt C, Ch 7).

SECTION 4

CARGO CONTAINMENT

1 General

1.1

1.1.1

Several types of hydrocarbons are normally produced from the liquefaction process. Each of these hydrocarbons will have to be stored in separate tanks.

As a consequence, there may be a combination of containment types required dependent on the type, conditions and quantities of hydrocarbon fluids produced which are in turn dependent on the make-up of the feed gas into the liquefaction process.

Liquid hydrocarbons (condensate) separated from the feed gas are to be stored in dedicated tanks. The storage requirements for these liquids are dealt with in Pt E, Ch 1.

Gaseous hydrocarbons that are produced as liquids (NGLs) within the liquefaction process are to be stored under conditions similar to LPG carriers where the storage tank pressure is maintained via a reliquefaction process of the boil-off gases or the storage tanks are constructed such that they can maintain the pressure of the boil-off gases until off-loading or consumption. IGC Code Chapter 7 applies.

The LNG produced is to be stored under similar conditions to an LNG carrier where the boil-off gases are managed either by consumption as fuel or by reliquefaction by injection back into the liquefaction train. IGC Code Chapter 7 applies.

The requirements in this Section apply to LPG and LNG storage tanks.

2 LPG and LNG storage

2.1 Symbols

2.1.1

k : Material factor for steel, defined in Pt B, Ch 4, Sec 1, [2.3] of the Rules for the Classification of Ships

2.2 Design pressure in harbour conditions

2.2.1

IGC CODE REFERENCE : Ch 4, 4.2.6.4

Where the vapour pressure in harbour conditions is greater than p_0 , defined in IGC 4.2.6.4, this value is to be specified in the operating instructions for the unit's Master.

2.3 Design temperature

2.3.1 Use of cargo heater to raise the cargo temperature

IGC CODE REFERENCE : Ch 4, 4.2.7

Where a cargo heater, intended to raise the cargo temperature to a value permissible for cargo tanks, is envisaged, the following requirements are to be complied with:

- the piping and valves involved are to be suitable for the design loading temperature
- a thermometer is to be fitted at the heater outlet. It is to be set at the design temperature of the tanks and, when activated, it is to give a visual and audible alarm. This alarm is to be installed in the cargo control station or, when such a station is not foreseen, in the wheelhouse.
- The following note is to be written on the Certificate of Fitness: "The minimum permissible temperature in the cargo preheater is..... °C".

3 Design loads

3.1 General

3.1.1

The effects of accidental loading on the design of the structural elements are to be addressed by Risk Analysis (Pt C, Ch 7). Particular emphasis is to be put on the locations where personnel can be present in normal and emergency conditions (accommodation, escape routes, temporary refuges, LSA stations etc.).

3.2 Internal pressure for integral tanks, membrane tanks and type A independent tanks

3.2.1 General

The inertial internal liquid pressure is to be calculated according to Part B, Chapter 5.

3.3 Internal pressure for type B and C independent tanks

3.3.1 General

IGC CODE REFERENCE : Ch 4, 4.3.2

The inertial internal liquid pressure is to be calculated considering the unit in the following mutually exclusive conditions:

Figure 1 : Dimensionless acceleration in upright unit condition

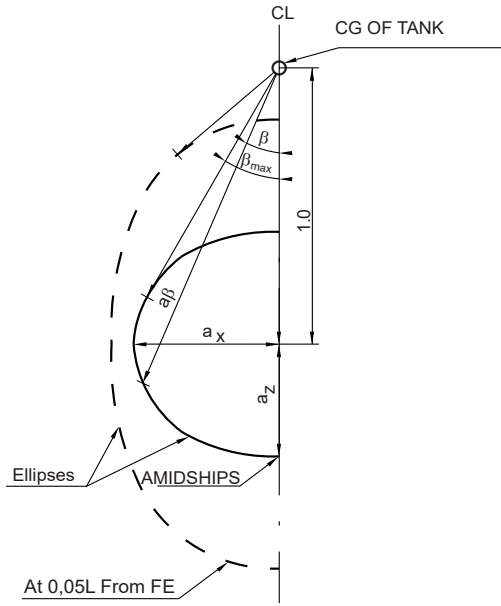

Figure 2 : Dimensionless acceleration in inclined unit condition

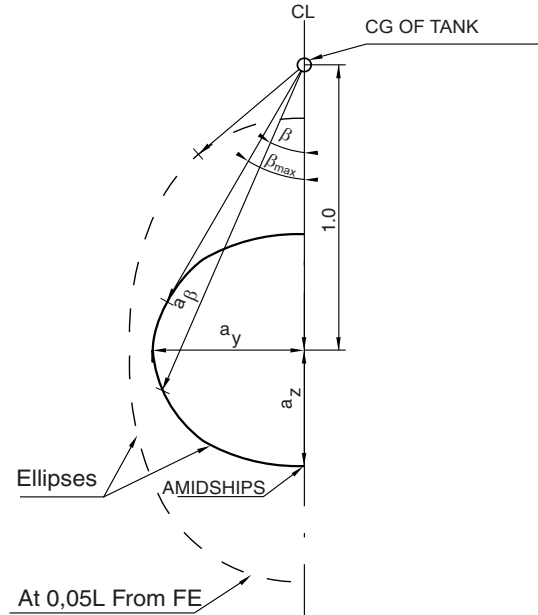
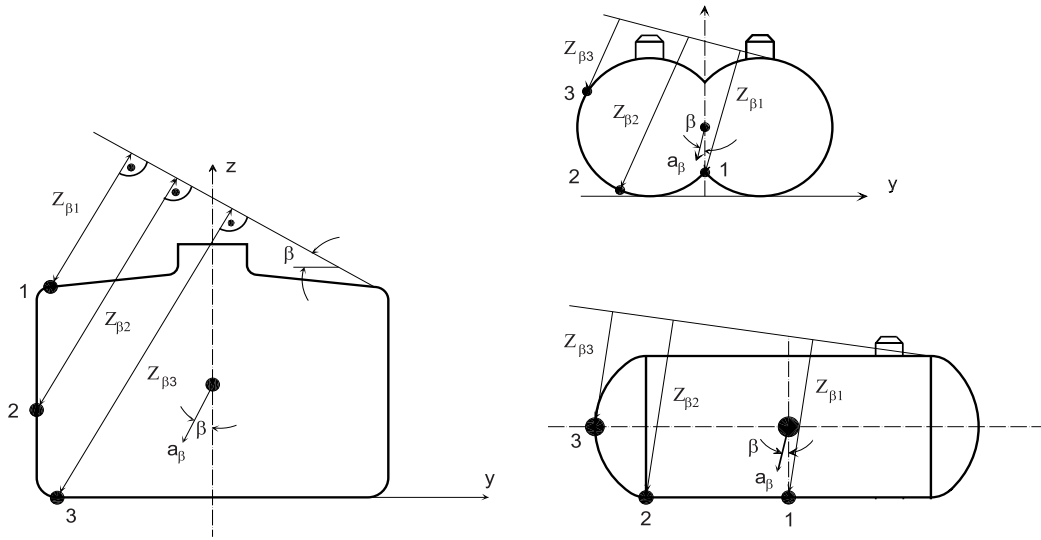

Figure 3 : Determination of liquid height Z_{β} for pressure points 1, 2 and 3



- upright unit conditions (see [3.3.2])
- inclined unit conditions (see [3.3.3]).

3.3.2 Accelerations in upright unit conditions

In these conditions, the unit encounters waves which produce unit motions in the X-Z plane, i.e. surge, heave and pitch.

The dimensionless acceleration a_{β} is to be obtained, for an arbitrary direction β in accordance with Fig 1, in which the wave transverse and vertical accelerations a_x and a_z ,

respectively, are calculated from the formula in IGC Code 4.12.

3.3.3 Accelerations in inclined unit conditions

In these conditions, the unit encounters waves which produce unit motions in the X-Y and Y-Z planes, i.e. sway, heave, roll and yaw.

The dimensionless acceleration a_{β} is to be obtained, for an arbitrary direction β in accordance with Fig 2, in which the wave longitudinal and vertical accelerations a_y and a_z , respectively, are calculated from the formula in IGC Code 4.12.

3.3.4 Liquid heights and pressure

IGC CODE REFERENCE : Ch 4, 4.3.2.2

The liquid heights Z_{β} are to be calculated in accordance with Fig 3 at each calculation point of the tank.

At each calculation point, the maximum internal pressure ($P_{gd}/_{max}$) is to be obtained for the β direction which gives the maximum value of P_{gdr} according to IGC 4.3.2.2 (see Fig 4).

3.3.5 Cargo mass density -

IGC CODE REFERENCE : Ch 4, 4.3.2.2

Where the maximum mass density of the liquid stored is not given, the following values, in t/m^3 , are to be considered:

- $\rho_L = 0,50 t/m^3$ for methane
- $\rho_L = 0,58 t/m^3$ for propane
- $\rho_L = 0,60 t/m^3$ for butane
- $\rho_L = 0,70 t/m^3$ for ammonia (anhydrous).

4 Hull scantlings

4.1 Plating

4.1.1 Minimum net thicknesses -

IGC CODE REFERENCE : Ch 4, 4.4

The net thickness of the weather strength deck, trunk deck, tank bulkhead and watertight bulkhead plating within or bounding the longitudinal extension of the cargo area is to be not less than the values given in Tab 1.

Table 1 : Minimum net thickness of the weather strength deck, trunk deck, tank bulkhead and watertight bulkhead plating -

Plating	Minimum net thickness, in mm	
Weather strength deck and trunk deck at midship	Longitudinal framing	$1,6 + 0,032 L k^{1/2} + 4,5 s$ for $L < 220$ $6 k^{1/2} + 5,7 + s$ for $L \geq 220$
	Transverse framing	$1,6 + 0,04 L k^{1/2} + 4,5 s$ for $L < 220$ $6 k^{1/2} + 7,5 + s$ for $L \geq 220$
Weather strength deck and trunk deck at ends and between hatchways	$2,1 + 0,013 L k^{1/2} + 4,5 s$	
Tank bulkhead	$1,7 + 0,013 L k^{1/2} + 4,5 s$	
Watertight bulkhead	$1,3 + 0,013 L k^{1/2} + 4,5 s$	
Note 1:		
s : Length, in m, of the shorter side of the plate panel.		

4.3 Primary supporting members

4.3.1 Minimum net thicknesses -

The net thickness of plating which forms the webs of primary supporting members is to be not less than the value obtained, in mm, from the following formula:

$$t_{MIN} = 4,1 + 0,015 L k^{1/2}$$

4.2 Ordinary stiffeners

4.2.1 Minimum net thicknesses -

The net thickness of the web of ordinary stiffeners is to be not less than the value obtained, in mm, from the following formulae:

$$t_{MIN} = 0,8 + 0,013 L k^{1/2} + 4,5 s \quad \text{for } L < 220 \text{ m}$$

$$t_{MIN} = 3 k^{1/2} + 4,5 + s \quad \text{for } L \geq 220 \text{ m}$$

where s is the spacing, in m, of ordinary stiffeners.

Figure 4 : Determination of internal pressure for pressure points 1, 2 and 3 -

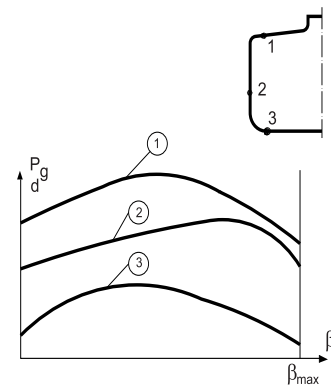

5 Structural analysis of integral tanks

5.1 Scantlings

5.1.1 -

IGC CODE REFERENCE : Ch 4, 4.4.1

The net scantlings of plating, ordinary stiffeners and primary supporting members of integral tanks are to be not less than those obtained from Part B, Chapter 7, where the hull girder loads and the internal pressure are to be calculated according to Part B, Chapter 5.

6 Structural analysis of membrane tanks

6.1 General

6.1.1 -

Specific allowable hull girder stresses and/or deflections, indicated by the Designer, are to be taken into account for the determination of the scantlings.

6.2 Scantlings

6.2.1 -

IGC CODE REFERENCE : Ch 4, 4.4.2

The net scantlings of plating, ordinary stiffeners and primary supporting members of membrane tanks are to be not less than those obtained from Part B, Chapter 7, where the hull girder loads and the internal pressure are to be calculated according to Part B, Chapter 5.

7 Structural analysis of type A independent tanks

7.1 Scantlings

7.1.1 -

IGC CODE REFERENCE : Ch 4, 4.4.4

The net scantlings of plating, ordinary stiffeners and primary supporting members of type A independent tanks are to be not less than those obtained from Part B, Chapter 7, where the hull girder loads and the internal pressure are to be calculated according to Part B, Chapter 5.

When calculating the internal pressure, the presence of the dome may be disregarded.

8 Structural analysis of type B independent tanks

8.1 Plating and ordinary stiffeners

8.1.1 Strength check of plating and ordinary stiffeners subject to lateral pressure

-

IGC CODE REFERENCE : Ch 4, 4.5

The net scantlings of plating and ordinary stiffeners of type B independent tanks are to be not less than those obtained from the applicable formulae in Part B, Chapter 7, where the internal pressure is to be calculated according to [2.2].

8.1.2 Buckling check -

IGC CODE REFERENCE : Ch 4, 4.5

The scantlings of plating and ordinary stiffeners of type B independent tanks are to be not less than those obtained from the applicable formulae in Part B, Chapter 7.

8.2 Primary supporting members

8.2.1 Analysis criteria -

IGC CODE REFERENCE : Ch 4, 4.5

The analysis of the primary supporting members of the tank subjected to lateral pressure based on a three dimensional model is to be carried out according to the following requirements:

- the structural modelling is to comply with the requirements from Pt B, Ch 7, App 1, [1] to Pt B, Ch 7, App 1, [3] of the Rules for the Classification of Ships
- the stress calculation is to comply with the requirements in Pt B, Ch 7, App 1, [5] of the Rules for the Classification of Ships
- the model extension is to comply with [8.2.2]
- the wave hull girder loads and the wave pressures to be applied on the model are to comply with [8.2.3]
- the inertial loads to be applied on the model are to comply with [8.2.4].

8.2.2 Model extension -

The longitudinal extension of the structural model is to comply with Pt B, Ch 7, App 1, [3.2] of the Rules for the Classification of Ships. In any case, the structural model is to include the hull and the tank with its supporting and keying system.

8.2.3 Wave hull girder loads and wave pressures -

IGC CODE REFERENCE : Ch 4, 4.5

Wave hull girder loads and wave pressures are to be obtained from a complete analysis of the unit motion and accelerations in irregular waves, to be submitted to the Society for approval, unless these data are available from similar units.

These loads are to be obtained as the most probable the unit may experience during its operating life, for a probability level of 10^{-8} .

8.2.4 Inertial loads -

IGC CODE REFERENCE : Ch 4, 4.5

The inertial loads are to be obtained from the formulae in IGC 4.3.2.

8.2.5 Yielding check of primary supporting members of type B independent tanks primarily constructed of bodies of revolution

-

IGC CODE REFERENCE : Ch 4, 4.5

The equivalent stresses of primary supporting members are to comply with the following formula:

$$\sigma_E \leq \sigma_{ALL}$$

where:

σ_E : Equivalent stress, in N/mm², to be obtained from the formula in IGC 4.5.1.8 for each of the following stress categories, defined in IGC 4.13:

- primary general membrane stress
- primary local membrane stress
- primary bending stress
- secondary stress

σ_{ALL} : Allowable stress, defined in IGC 4.5.1.4 for each of the stress categories above.

8.2.6 Yielding check of primary supporting members of type B independent tanks primarily constructed of plane surfaces

IGC CODE REFERENCE : Ch 4, 4.5

The equivalent stresses of primary supporting members are to comply with the following formula:

$$\sigma_E \leq \sigma_{ALL}$$

where:

σ_E : Equivalent stress, in N/mm², to be obtained from the formulae in Pt B, Ch 7, App 1, [5.1] of the Rules for the Classification of Ships, as a result of direct calculations to be carried out in accordance with [8.2.1]

σ_{ALL} : Allowable stress, in N/mm², to be obtained from Tab 2.

Table 2 : Allowable stress for primary supporting members primarily constructed of plane surfaces -

Material	Allowable stress, in N/mm ²
C-Mn steel and Ni-steels	The lesser of: <ul style="list-style-type: none"> • 0,75 R_{eH} • 0,5 R_m
Austenitic steels	The lesser of: <ul style="list-style-type: none"> • 0,80 R_{eH} • 0,4 R_m
Aluminium alloy	The lesser of: <ul style="list-style-type: none"> • 0,75 R_{eH} • 0,35 R_m
Note 1:	
R _{eH}	: Minimum yield stress, in N/mm ² , of the material, as defined in Pt B, Ch 4, Sec 1, [2.1] of the Rules for the Classification of Ships
R _m	: Ultimate minimum tensile strength, in N/mm ² , of the material, as defined in Pt B, Ch 4, Sec 1, [2.1] of the Rules for the Classification of Ships.

8.2.7 Local buckling check of plate panels of primary supporting members -

IGC CODE REFERENCE : Ch 4, 4.5

A local buckling check are to be carried out according to Pt B, Ch 7, Sec 1, [5] of the Rules for the Classification of Ships for plate panels which constitute primary supporting members.

In performing this check, the stresses in the plate panels are to be obtained from direct calculations to be carried out in accordance with [8.2.1].

8.3 Fatigue analysis

8.3.1 General -

IGC CODE REFERENCE : Ch 4, 4.4.5.6

The fatigue analysis is to be performed for areas where high wave induced stresses or large stress concentrations are

expected, for welded joints and parent material. Such areas are to be defined by the Designer and agreed by the Society on a case-by-case basis.

8.3.2 Material properties -

IGC CODE REFERENCE : Ch 4, 4.4.5.6

The material properties affecting fatigue of the items checked are to be documented. Where this documentation is not available, the Society may request to obtain these properties from experiments performed in accordance with recognised standards.

8.3.3 Wave loads -

In upright unit and in inclined unit conditions the wave loads to be considered for the fatigue analysis of the tank include:

- maximum and minimum wave hull girder loads and wave pressures, to be obtained from a complete analysis of the unit motion and accelerations in irregular waves, to be submitted to the Society for approval, unless these data are available from similar units. These loads are to be obtained as the most probable the unit may experience during its operating life, for a probability level of 10⁻⁸.
- Maximum and minimum inertial pressures, to be obtained from the formulae in IGC 4.3.2 as a function of the arbitrary direction β .

8.3.4 Simplified stress distribution for fatigue analysis -

IGC CODE REFERENCE : Ch 4, 4.3.4.3

The simplified long-term distribution of wave loads indicated in IGC Code 4.3.4.3 may be represented by means of 8 stress ranges, each characterised by an alternating stress $\sigma_{\pm i}$ and a number of cycles n_i (see Fig 5). The corresponding values of σ_i and n_i are to be obtained from the following formulae:

$$\sigma_i = \sigma_0 \left(1,0625 - \frac{i}{8} \right)$$

$$n_i = 0,9 \cdot 10^i$$

where:

- σ_i : Stress (i = 1, 2, ..., 8), in N/mm² (see Fig 5)
- σ_0 : Most probable maximum stress over the life of the unit, in N/mm², for a probability level of 10⁻⁸
- n_i : Number of cycles for each stress σ_i considered (i = 1, 2, ..., 8).

8.3.5 Conventional cumulative damage -

IGC CODE REFERENCE : Ch 4, 4.4.5.6

For each structural detail for which the fatigue analysis is to be carried out, the conventional cumulative damage is to be calculated according to the following procedure:

- the long-term value of hot spot stress range $\Delta\sigma_{S,0}$ is to be obtained from the following formula:

$$\Delta\sigma_{S,0} = |\sigma_{S,MAX} - \sigma_{S,MIN}|$$

where:

$\sigma_{S,MAX}$, $\sigma_{S,MIN}$: Maximum and minimum hot spot stress to be obtained from a structural analysis carried out in accordance with Pt B, Ch 7, App 1 of the Rules for the Classification of Ships, where the wave loads are those defined in [8.3.3]

- the long-term value of the notch stress range $\Delta\sigma_{N,0}$ is obtained from the formulae in Pt B, Ch 7, Sec 2, [3.3] as a function of the hot spot stress range $\Delta\sigma_{S,0}$
- the long-term distribution of notch stress ranges $\Delta\sigma_{N,i}$ is to be calculated. Each stress range $\Delta\sigma_{N,i}$ of the distribution, corresponding to n_i stress cycles, is obtained from the formulae in [8.3.4], where σ_0 is taken equal to $\Delta\sigma_{N,0}$.
- For each notch stress range $\Delta\sigma_{N,i}$, the number of stress cycles N_i which cause the fatigue failure is to be obtained by means of S-N curves corresponding to the as-rolled condition (see Fig 6). The criteria adopted for obtaining the S-N curves are to be documented. Where this documentation is not available, the Society may

require the curves to be obtained from experiments performed in accordance with recognised standards.

- The conventional cumulative damage for the i notch stress ranges $\Delta\sigma_{N,i}$ is to be obtained from the formula in IGC 4.4.5.6.

Figure 5 : Simplified stress distribution for fatigue analysis -

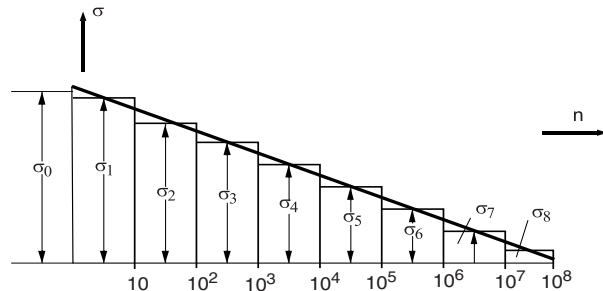
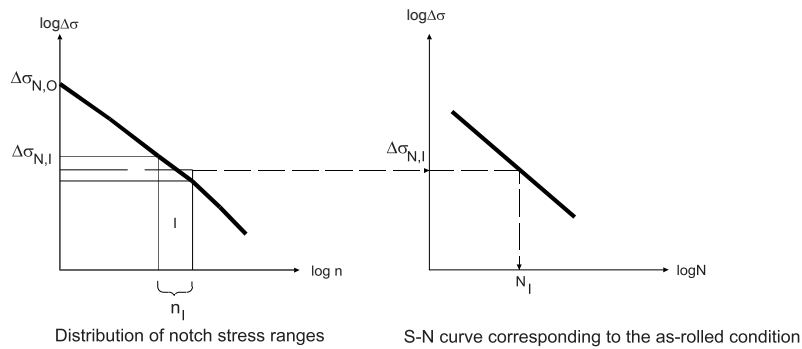

Figure 6 : Fatigue check based on conventional cumulative damage method -



8.3.6 Check criteria -

The conventional cumulative damage, to be calculated according to [8.3.5], is to be not greater than C_{WV} defined in IGC 4.4.5.6.

8.4 Crack propagation analysis

8.4.1 General -

IGC CODE REFERENCE : Ch 4, 4.4.5

The crack propagation analysis is to be carried out for highly stressed areas. The latter are to be defined by the Designer and agreed by the Society on a case-by-case basis. Propagation rates in the parent material, weld metal and heat-affected zone are to be considered.

The following checks are to be carried out:

- crack propagation from an initial defect, in order to check that the defect will not grow and cause a brittle fracture before the defect is detected; this check is to be carried out according to [8.4.4]
- crack propagation from an initial through thickness defect, in order to check that the defect, resulting in a leakage, will not grow and cause a brittle fracture less than 15 days after its detection; this check is to be carried out according to [8.4.5].

8.4.2 Material properties -

IGC CODE REFERENCE : Ch 4, 4.4.5

The material fracture mechanical properties used for the crack propagation analysis, i.e. the properties relating the crack propagation rate to the stress intensity range at the crack tip, are to be documented for the various thicknesses of parent material and weld metal alike. Where this documentation is not available, the Society may request to obtain these properties from experiments performed in accordance with recognised standards.

8.4.3 Simplified stress distribution for crack propagation analysis -

IGC CODE REFERENCE : Ch 4, 4.3.4.4

The simplified wave load distribution indicated in IGC Code 4.3.4.4 may be represented over a period of 15 days by means of 5 stress ranges, each characterised by an alternating stress $\sigma_{\pm i}$ and number of cycles, n_i (see Fig 7). The corresponding values of σ_i and n_i are to be obtained from the following formulae:

$$\sigma_i = \sigma_0 \left(1, 1 - \frac{i}{5,3} \right)$$

$$n_i = 0,913 \cdot 10^i$$

where:

- σ_i : Stress ($i = 1,06; 2,12; 3,18; 4,24; 5,30$), in N/mm^2 , (see Fig 7)
- σ_0 : Defined in [8.3.4]
- n_i : Number of cycles for each stress σ_i considered ($i = 1,06; 2,12; 3,18; 4,24; 5,30$).

Figure 7 : Simplified stress distribution for crack propagation analysis -

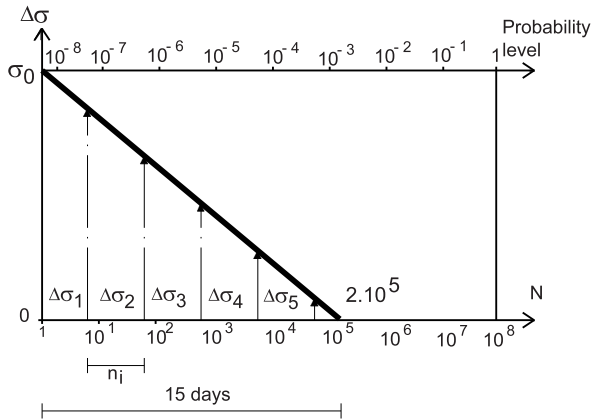

8.4.4 Crack propagation analysis from an initial defect -

IGC CODE REFERENCE : Ch 4, 4.4.5

It is to be checked that an initial crack will not grow, under wave loading based on the stress distribution in [8.3.4], beyond the allowable crack size.

The initial size and shape of the crack is to be considered by the Society on a case-by-case basis, taking into account the structural detail and the inspection method.

The allowable crack size is to be considered by the Society on a case-by-case basis; in any event, it is to be taken less than that which may lead to a loss of effectiveness of the structural element considered.

8.4.5 Crack propagation analysis from an initial through thickness defect -

IGC CODE REFERENCE : Ch 4, 4.4.5

It is to be checked that an initial through thickness crack will not grow, under dynamic loading based on the stress distribution in [8.4.3], beyond the allowable crack size.

The initial size of the through thickness crack is to be taken not less than that through which the minimum flow size that can be detected by the monitoring system (e.g. gas detectors) may pass.

The allowable crack size is to be considered by the Society on a case-by-case basis; in any event, it is to be taken far less than the critical crack length, defined in [8.4.6].

8.4.6 Critical crack length -

IGC CODE REFERENCE : Ch 4, 4.4.5

The critical crack length is the crack length from which a brittle fracture may initiate and it is to be considered by the Society on a case-by-case basis. In any event, it is to be evaluated for the most probable maximum stress experienced by the structural element in the unit life, which is equal to the stress in the considered detail obtained from

the structural analysis to be performed in accordance with [8.2.1].

9 Structural analysis of type C independent tanks

9.1 Stiffening rings in way of tank supports

9.1.1 Structural model -

IGC CODE REFERENCE : Ch 4, 4.4.6

The stiffening rings in way of supports of horizontal cylindrical tanks are to be modelled as circumferential beams constituted by web, flange, doubler plate, if any, and plating attached to the stiffening rings.

9.1.2 Width of attached plating -

IGC CODE REFERENCE : Ch 4, 4.4.6

On each side of the web, the width of the attached plating to be considered for the yielding and buckling checks of the stiffening rings, as in [9.1.5] and [9.1.6], respectively, is to be obtained, in mm, from the following formulae:

- $b = 0,78\sqrt{rt}$ for cylindrical shell,
- $b = 20 t_b$ for longitudinal bulkheads (in the case of lobe tanks)

where:

r : Mean radius, in mm, of the cylindrical shell

t : Shell thickness, in mm

t_b : Bulkhead thickness, in mm.

A doubler plate, if any, may be considered as belonging to the attached plating.

9.1.3 Boundary conditions -

IGC CODE REFERENCE : Ch 4, 4.4.6

The boundary conditions of the stiffening ring are to be modelled as follows:

- circumferential forces applied on each side of the ring, whose resultant is equal to the shear force in the tank and calculated through the bi-dimensional shear flow theory
- reaction forces in way of tank supports, to be obtained according to [10.2].

9.1.4 Lateral pressure -

IGC CODE REFERENCE : Ch 4, 4.4.6

The lateral pressure to be considered for the check of the stiffening rings is to be obtained from [3.2].

9.1.5 Yielding check -

IGC CODE REFERENCE : Ch 4, 4.4.6

The equivalent stress in stiffening rings in way of supports is to comply with the following formula:

$$\sigma_E \sigma \leq \sigma_{ALL}$$

where:

σ_E : Equivalent stress in stiffening rings calculated for the load cases defined in IGC 4.6.2 and IGC 4.6.3, in N/mm^2 , and to be obtained from the following formula:

$$\sigma_E = \sqrt{(\sigma_N + \sigma_B) + 3\tau^2}$$

- σ_N : Normal stress, in N/mm², in the circumferential direction of the stiffening ring
- σ_B : Bending stress, in N/mm², in the circumferential direction of the stiffening ring
- τ : Shear stress, in N/mm², in the stiffening ring
- σ_{ALL} : Allowable stress, in N/mm², to be taken equal to the lesser of the following values:
- 0,57 R_m
 - 0,85 R_{eH}
- R_m : Defined in Pt B, Ch 4, Sec 1, [2.1] of the Rules for the Classification of Ships
- R_{eH} : Defined in Pt B, Ch 4, Sec 1, [2.1] of the Rules for the Classification of Ships.

9.1.6 Buckling check -

IGC CODE REFERENCE : Ch 4, 4.4.6

The buckling strength of the stiffening rings is to be checked in compliance with the applicable formulae in Pt B, Ch 7, Sec 2 of the Rules for the Classification of Ships.

10 Supports

10.1 Structural arrangement

10.1.1 General -

REFERENCE IGC CODE : Ch 4, 6

The reaction forces in way of tank supports are to be transmitted as directly as possible to the hull primary supporting members, minimising stress concentrations.

Where the reaction forces are not in the plane of primary members, web plates and brackets are to be provided in order to transmit these loads by means of shear stresses.

10.1.2 Structure continuity -

Special attention is to be paid to continuity of structure between circular tank supports and the primary supporting members of the unit.

10.1.3 Openings -

IGC CODE REFERENCE : Ch 4, 4.6

In primary supporting members of tank supports and hull structures in way of tank supports which constitute hull supports, openings are to be avoided and local strengthening may be necessary.

10.1.4 Antiflotation arrangements -

IGC CODE REFERENCE : Ch 4, 4.6.7

Adequate clearance between the tanks and the hull structures is to be provided in all operating conditions.

10.2 Calculation of reaction forces in way of tank supports

10.2.1 -

IGC CODE REFERENCE : Ch 4, 4.6

The reaction forces in way of tank supports are to be obtained from the structural analysis of the tank or stiffening

rings in way of tank supports, considering the loads specified in:

- [7], for the structural analysis of type A independent tanks
- [8], for the structural analysis of type B independent tanks
- [9], for the structural analysis of type C independent tanks.

The final distribution of the reaction forces at the supports is not to show any tensile forces.

10.3 Keys

10.3.1 General -

Fillings lower than 90% are generally not admitted for tanks having no upper rolling keys.

The structure of the tank and of the unit is to be reinforced in way of the keys so as to support the reactions and the corresponding moments.

10.3.2 Rolling keys -

Rolling keys are to be checked under transverse and vertical accelerations, defined in Pt B, Ch 5, Sec 3, [3.4.1] for the inclined unit conditions, and applied on the maximum weight of the full tank.

It is to be checked that the combined stress in rolling keys is in compliance with the following formula:

$$\sigma_{ALL} > \sigma_C$$

where:

- σ_{ALL} : Allowable stress, in N/mm², to be taken equal to the minimum of 0,75 R_{eH} and 0,5 R_m
- R_{eH} : Yield stress, in N/mm², of the steel used, at 20°C
- R_m : Minimum ultimate tensile strength, in N/mm², at 20°C.

10.3.3 Pitching keys -

Pitching keys are to be checked under longitudinal accelerations, to be taken not less than 0,3, and vertical accelerations, defined in Pt B, Ch 5, Sec 3, [3.4.1] for the upright conditions, and applied on the maximum weight of the full tank.

It is to be checked that the combined stress in pitching keys is in compliance with the following formula:

$$\sigma_{ALL} > \sigma_C$$

where:

- σ_{ALL} : Allowable stress, in N/mm², defined in [10.3.2].

10.4 Scantlings of type C independent tank supports and hull structures in way

10.4.1 -

IGC CODE REFERENCE : Ch 4, 4.6

The net scantlings of plating, ordinary stiffeners and primary supporting members of tank supports and hull structures in way are to be not less than those obtained by applying the criteria in Part B, Chapter 7.

The hull girder loads and the lateral pressure to be considered in the formulae above are to be obtained from the formulae in Part B, Chapter 5.

The values of reaction forces in way of tank supports to be considered for the scantlings of these structural elements are to be obtained from a structural analysis of the tank (see 10.2) in which the unit accelerations defined in [3.3] are multiplied by 0,625.

11 Secondary barrier

11.1 Secondary barrier extent

11.1.1 -

IGC CODE REFERENCE : Ch 4, 4.7

The extent of the secondary barrier is to be not less than that necessary to protect the hull structures assuming that the cargo tank is breached at a static angle of heel of 30°, with an equalisation of the liquid cargo in the tank (see Fig 8).

Figure 8 : Secondary barrier extension -

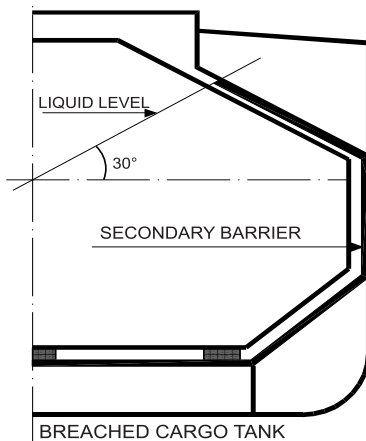

12 Insulation

12.1 Heating of structures

12.1.1 Segregation of heating plant -

IGC CODE REFERENCE : Ch 4, 4.8.4

Where a hull heating system complying with IGC 4.8.4 is installed, this system is to be contained solely within the cargo area or the drain returns from the hull heating coils in the wing tanks, cofferdams and double bottom are to be led to a degassing tank. The degassing tank is to be located in the cargo area and the vent outlets are to be located in a safe position and fitted with a flame screen.

12.1.2 Temperature of steam and heating media within the cargo area -

IGC CODE REFERENCE : Ch 4, 4.8.4

The maximum temperature of steam and heating media within the cargo area is to be adjusted to take into account the temperature class of the cargoes.

13 Materials

13.1 Insulation material characteristics

13.1.1 -

IGC CODE REFERENCE : Ch 4, 4.9.5 AND 4.9.6

The materials for insulation are to be approved by the Society.

The approval of bonding materials, sealing materials, lining constituting a vapour barrier or mechanical protection is to be considered by the Society on a case-by-case basis. In any event, these materials are to be chemically compatible with the insulation material.

13.1.2 -

IGC CODE REFERENCE : Ch 4, 4.9.5 AND 4.9.6

Before applying the insulation, the surfaces of the tank structures or of the hull are to be carefully cleaned.

13.1.3 -

IGC CODE REFERENCE : Ch 4, 4.9.5 AND 4.9.6

Where applicable, the insulation system is to be suitable to be visually examined at least on one side.

13.1.4 -

IGC CODE REFERENCE : Ch 4, 4.9.5 AND 4.9.6

When the insulation is sprayed or foamed, the minimum steel temperature at the time of application is to be not less than the temperature given in the specification of the insulation.

14 Construction and testing

14.1 Integral tank testing

14.1.1 -

IGC CODE REFERENCE : Ch 4, 4.10.6

The testing of integral tanks is to comply with the requirements in Pt B, Ch 12, Sec 3 of the Rules for the Classification of Ships.

14.2 Membrane and semi-membrane tanks testing

14.2.1 -

IGC CODE REFERENCE : Ch 4, 4.10.7

The testing of membrane and semi-membrane tanks is to comply with the requirements in Pt B, Ch 12, Sec 3 of the Rules for the Classification of Ships.

14.3 Independent tank testing

14.3.1 -

IGC CODE REFERENCE : Ch 4, 4.10.10

The conditions in which testing is performed are to simulate as far as possible the actual loading on the tank and its supports.

14.3.2 -

IGC CODE REFERENCE : Ch 4, 4.10.10

When testing takes place after installation of the cargo tank, provision is to be made prior to the launching of the unit in order to avoid excessive stresses in the unit structures.

14.4 Final tests

14.4.1 -

IGC CODE REFERENCE : Ch 4, 4.10

The tests on the completed system are to be performed in the presence of a Surveyor and are to demonstrate that the cargo containment arrangements are capable of being inerted, cooled, loaded and unloaded in a satisfactory way and that all the safety devices operate correctly.

14.4.2 -

IGC CODE REFERENCE : Ch 4, 4.10

Tests are to be performed at the minimum service temperature or at a temperature very close to it.

14.4.3 -

IGC CODE REFERENCE : Ch 4, 4.10

The regasification, reliquefaction and inert gas production systems, if any, and the installation, if any, for use of gas as fuel for boilers and internal combustion engines are also to be tested to the satisfaction of the Surveyor.

14.4.4 -

IGC CODE REFERENCE : Ch 4, 4.10

All operating data and temperatures read during the first cargo operations are to be sent to the Society.

14.4.5 -

IGC CODE REFERENCE : Ch 4, 4.10

All data and temperatures read during subsequent cargo operations are to be kept at the disposal of the Society for a suitable period of time.

15 Structural details

15.1 Special structural details

15.1.1 -

The specific requirements in Pt B, Ch 13, Sec 2, [2.4] for units with the service notation FSRU are to be complied with.

15.2 Connections of the inner hull plating with intermediate plating

15.2.1 -

IGC CODE REFERENCE : Ch 4, 4.10

The connections of the inner hull plating with intermediate plating are to be made according to:

- sheets 4.5 to 4.7 in Pt B, Ch 12, App 1 of the Rules for the Classification of Ships for position 1 in Fig 9
- sheets 6.8 and 6.9 in Pt B, Ch 12, App 1 of the Rules for the Classification of Ships for position 2 in Fig 9
- for positions 3 and 4 in Fig 9, in a similar way to positions 1 and 2.

Figure 9 : Positions of connections -

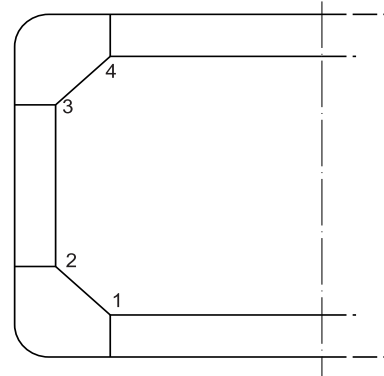

15.2.2 -

Where there is no prolonging bracket in way of knuckle joints in positions 1 and/or 2, the connection of transverse webs to the inner hull and longitudinal girder plating is to be made with partial penetration welds over a length not less than 400 mm.

15.3 Connections of inner bottom with transverse cofferdam bulkheads

15.3.1 General -

In addition to sheet 3.5 in Pt B, Ch 12, App 1 of the Rules for the Classification of Ships, the requirements in [15.3.2] to [15.3.4] apply.

15.3.2 Floors -

IGC CODE REFERENCE : Ch 4, 4.10

The thickness and material properties of the supporting floors are to be at least equal to those of the cofferdam bulkhead plating.

15.3.3 Vertical webs within cofferdam bulkhead -

IGC CODE REFERENCE : Ch 4, 4.10

Vertical webs fitted within the cofferdam bulkhead are to be aligned with the double bottom girders.

15.3.4 Manholes -

IGC CODE REFERENCE : Ch 4, 4.10

Manholes in double bottom floors aligned with the cofferdam bulkhead plating are to be located as low as practicable and at mid-distance between two adjacent longitudinal girders.

15.4 Cut-outs and connections

15.4.1 Cut-outs -

IGC CODE REFERENCE : Ch 4, 4.10

Cut-outs for the passage of inner hull and cofferdam bulkhead ordinary stiffeners through the vertical webs are to be closed by collar plates welded to the inner hull plating.

15.4.2 Connection of the cargo containment system to the hull structure -

IGC CODE REFERENCE : Ch 4, 4.10

Where deemed necessary, adequate reinforcements are to be fitted in the double hull and transverse cofferdams at connection of the cargo containment system to the hull structure. Details of the connection are to be submitted to the Society for approval.

SECTION 5

LIQUEFACTION PROCESS SYSTEMS, PROCESS PRESSURE VESSELS AND LIQUID, VAPOUR AND PRESSURE PIPING SYSTEMS

1 Liquefaction process systems

1.1 General

1.1.1 -

Hydrocarbon process systems and associated equipment are to be designed to minimise the associated risks, in particular by:

- Preventing the escalation of an undesired event.
- Preventing an undesired event from causing a release of hydrocarbons.
- Safely dispersing or eliminating hydrocarbon gasses and vapours released.
- Safely collecting and containing hydrocarbon liquids released.
- Preventing formation of explosive mixtures.
- Preventing ignition of flammable liquids or gasses and vapours released.
- Limiting the exposure of personnel to fire hazards.

The following is a non-exhaustive list of design requirements.

- a) The design is to be single-failure-tolerant, i.e. a single failure or operator error is not to result in a major hazard, or damage to the unit or installation.
- b) Appropriate measures are to be provided to enable timely detection, control and mitigation of hazards.
- c) Escalation to plant and areas that are not affected by the initiating event is to be avoided.
- d) Cross-contamination of the refrigerants with cargo is to be avoided, by ensuring that the pressure on the refrigeration side of the cargo heat exchanger is higher than on the cargo side. For FLNG units this is particularly important if hydrocarbon based refrigerants are used within the liquefaction process.
- e) Proper containment systems are to be provided for equipment with potential for significant leakage, to be constructed of materials suitable for sustaining low temperatures. Care is to be taken to ensure that evaporating cryogenic gases do not contaminate lower modules.
- f) The availability of auxiliary systems serving the process system and on which the process system may depend is also to be considered in selection of design code and specification of such systems as stated in Section 17. The process and support systems are to be in accordance with Pt C, Ch 6, Sec 2.

- g) It is to be ensured that the gas fed to the liquefaction plant does not contain such a concentration of substances liable to solidify as to create process problems, fouling or plugging.
- h) The issue of thermal effects on piping, fittings and equipment is to be taken into account.

The processes involved in the liquefaction of Natural Gas offshore aboard an FLNG plant are based on those processes used to perform the same function on a shore based unit. However, the novel aspects due to the marinisation of these processes and the management of the interfaces of the topsides with the hull require ad-hoc considerations, based on Risk Analysis (Pt C, Ch 7), engineering studies, tests or other activities as needed, which are to be class approved.

1.1.2 Gas processing -

The gas processing facilities are to be considered to include all systems and components for the reception of raw feed gas from wells for such processes as acid gas removal, dehydration and mercury removal. Their design and construction for offshore use are to be in accordance with internationally recognised standards as specified in Section 17.

1.1.3 Acid Gas (CO₂) Removal -

In general, the process involves passing the feed gas through tall contactor towers where the acid gas is absorbed by contact with an amine solution. The process is well proven in shore based liquefaction plants and the design of the onboard system is to be based on the standards used for the onshore plant. Consideration of the FLNG unit's motions and the volume of fluids involved is to be taken into account when stability calculations are performed according to Pt B, Ch 3, Sec 2.

1.1.4 Dehydration -

Shore based techniques of removing moisture by molecular sieves are to be constructed to internationally recognised standards as specified in Sec 17 and the design and use of this equipment offshore are to follow these standards and also be deemed suitable for use in the offshore environment. The static nature of this equipment offers less stability risk than fluid based moisture removal systems. Like acid gas, moisture within the feed gas can pose considerable solid formation risks within the liquefaction process and is to be eliminated as far as possible.

1.1.5 Mercury removal -

Mercury in the feed gas has been proven to have a detrimental effect on aluminium based heat exchangers. Since aluminium offers a lightweight alternative offshore, mercury removal is essential for continued safe and productive operation of the liquefaction process.

Shore based systems combine the technology of molecular sieves for dehydration and the mercury removal process into one unit which has superior space saving advantages on an FLNG facility. Mercury removal based on internationally recognised standards as specified in Sec 17 is to be installed to protect heat exchangers.

1.1.6 Liquefaction -

The liquefaction facilities are to be considered to include all systems and components for pre-cooling, fractionating, main cryogenic refrigeration and storage. There are a number of proven, proprietary liquefaction methods already in onshore plants and the system used for an FLNG unit is to be designed and built to similar specifications. The subsystems within the liquefaction process are to be designed and constructed to Internationally recognised standards as specified in Sec 17 and, where applicable, in accordance with Part C, Ch 6, Sec 2.

1.2 Design and construction

1.2.1 -

The design and construction of liquefaction systems are to be in accordance with internationally recognised standards, as specified in Sec 17, and with the requirements of this Section. The standards are to be adhered to in their entirety. The use of other standards is subject to approval by the Society.

2 Process pressure vessels

2.1

2.1.1 -

IGC CODE REFERENCE : Ch 5, 5.1.2

Process pressure vessels handling cargo are to be considered at least as class 2 pressure vessels, in accordance with Pt C, Ch 1, Sec 3, [1.4.1] of the Rules for the Classification of Ships.

2.1.2 Temperature of steam and heating media within the cargo area -

IGC CODE REFERENCE : Ch 5, 5

The maximum temperature of steam and heating media within the cargo area is to be adjusted to take into account the temperature class of the cargoes.

3 Cargo and process piping

3.1 General

3.1.1 Cargo import and export system - Provisions for cargo import and export systems are given in Part C, Chapter 5.

3.1.2 Provisions for protection of piping against thermal stress -

IGC CODE REFERENCE : Ch 5, 5.2.1.2

Expansion joints are to be protected from extensions and compressions greater than the limits fixed for them and the

connected piping is to be suitably supported and anchored. Bellow expansion joints are to be protected from mechanical damage.

3.1.3 Segregation of high temperature piping -

IGC CODE REFERENCE : Ch 5, 5.2.1.3

High temperature pipes are to be thermally isolated from the adjacent structures. In particular, the temperature of pipelines is not to exceed 220 °C in gas-dangerous zones.

3.1.4 Pressure relief valve setting -

IGC CODE REFERENCE : Ch 5, 5.2.1.6

Pressure relief valves are to be set to discharge at a pressure not greater than the design pressure such that the overpressure during discharge does not exceed 110% of the design pressure.

3.1.5 Protection against leakage -

IGC CODE REFERENCE : Ch 5, 5.2.1

Where the piping system is intended for liquids having a boiling point lower than - 30 °C, permanent means to avoid possibility of contact between leaks and hull structures are to be provided in all those locations where leakage might be expected, such as shore connections, pump seals, flanges subject to frequent dismantling, etc.

3.1.6 Means for detecting the presence of liquid cargo -

IGC CODE REFERENCE : Ch 5, 5.2.1

The means to detect the presence of liquid cargo may be constituted by electrical level switches whose circuit is intrinsically safe. The alarm signals given by the level switches are to be transmitted to the wheelhouse and to the cargo control station, if provided.

3.1.7 Connections of relief valve discharges to cargo tanks -

IGC CODE REFERENCE : Ch 5, 5.2.1

The connections, if any, to the cargo tanks of relief valve discharges fitted on the liquid phase cargo piping are not to be fitted with shut-off valves, but are to be provided with non-return valves in the proximity of the tanks.

3.1.8 Centrifugal pumps -

IGC CODE REFERENCE : Ch 5, 5.2.1

Overpressure relief valves on cargo pumps may be omitted in the case of centrifugal pumps having a maximum delivery head, the delivery valve being completely closed, not greater than that permitted for the piping.

3.2 Design pressure

3.2.1 Design pressure definition -

IGC CODE REFERENCE : Ch 5, 5.2.3.1

For each piping section, the maximum pressure value among those applicable in paragraph 5.2.2.1 of the IGC Code is to be considered.

3.3 Flanges

3.3.1 Flanges not complying with standards -

IGC CODE REFERENCE : Ch 5, 5.2.4.5

For flanges not complying with a standard, the dimensions and type of gaskets are to be to the satisfaction of the Society.

3.4 Stress analysis

3.4.1 Calculations in accordance with recognised standards -

IGC CODE REFERENCE : Ch 5, 5.2.5

When such an analysis is required, it is to be carried out in accordance with the requirements listed below. Subject to this condition, calculations in accordance with recognised standards are admitted by the Society.

3.4.2 Calculation cases -

IGC CODE REFERENCE : Ch 5, 5.2.5

The calculations are to be made for every possible case of operation, but only those leading to the most unfavourable results are required to be submitted.

3.4.3 Loads to be taken for calculation - IGC CODE REFERENCE : Ch 5, 5.2.5

The calculations are to be carried out taking into account the following loads:

- a) piping not subject to green seas:
 - pressure
 - weight of the piping and of the internal fluid
 - contraction
- b) piping subject to green seas that is liable to be in operation at sea and in port:
 - pressure
 - weight of the piping and of the internal fluid
 - green seas
 - contraction
 - unit motion accelerations
- c) piping subject to green seas that is in operation only in port; the more severe of the following two combinations of loads:
 - pressure
 - weight of the pipe and of the internal fluid
 - contraction
 and
 - weight of the piping
 - green seas
 - expansion, assuming that the thermal stresses are fully relaxed.

3.4.4 Green sea directions - IGC

CODE REFERENCE : Ch 5, 5.2.5

When green seas are considered, their effects are to be studied, unless otherwise justified, in the following three directions:

- axis of the unit
- vertical
- horizontal, perpendicular to the axis of the unit.

3.4.5 Stress intensity -

IGC CODE REFERENCE : Ch 5, 5.2.5

The stress intensity is to be determined as specified in the formulae in Pt C, Ch 1, Sec 13, [2.3.2] of the Rules for the Classification of Ships for pipes intended for high temperatures:

- a) for primary stresses resulting from:
 - pressure
 - weight
 - green seas
- b) for primary stresses and secondary stresses resulting from contraction.

3.4.6 Stress intensity limits - IGC

CODE REFERENCE : Ch 5, 5.2.5

- a) For the first case, the stress intensity is to be limited to the lower of:

$$0,8 R_e \quad \text{and} \quad 0,4 R_m$$
- b) For the second case, the stress intensity is to be limited to the lower of:

$$1,6 R_e \quad \text{and} \quad 0,8 R_m.$$

3.4.7 Piping with expansion devices -

IGC CODE REFERENCE : Ch 5, 5.2.5

For piping fitted with expansion devices, their characteristics are to be submitted to the Society. Where these characteristics are such that the forces and moments at the ends of the devices are negligible for the contraction they must absorb, the calculation of the loads due to contraction in the corresponding piping is not required. It is, however, to be checked that the stress intensity corresponding to the primary stresses does not exceed the limits given in [3.4.6].

3.4.8 Flexibility coefficient -

IGC CODE REFERENCE : Ch 5, 5.2.5

The flexibility coefficient of elbows is to be determined from the formulae given in Pt C, Ch 1, Sec 13, [2.3.2] of the Rules for the Classification of Ships for pipes intended for high temperatures.

3.4.9 Local stresses -

IGC CODE REFERENCE : Ch 5, 5.2.5

Particular attention is to be paid to the calculation of local stresses in the assemblies subjected to axial forces and bending moments. The Society reserves the right to request additional justifications or local strengthening where considered necessary.

3.5 Aluminised pipes

3.5.1 -

IGC CODE REFERENCE : Ch 5, 5.2.6

Aluminised pipes may be fitted in ballast tanks, in inerted cargo tanks and, provided the pipes are protected from accidental impact, in hazardous areas on open deck.

4 Cargo system valving requirements

4.1 Cargo tank connections for gauging

4.1.1 Exemption -

IGC CODE REFERENCE : Ch 5, 5.6.2

The requirements in paragraph 5.6.2 of the IGC Code relevant to cargo tank connections for pressure gauges and measuring devices do not apply to tanks with an MARVS not exceeding 0,07 MPa.

4.2 Emergency shutdown

4.2.1 Clarification on location of fusible elements -

IGC CODE REFERENCE : Ch 5, 5.6.4

The cargo stations in way of which the fusible elements mentioned in paragraph 5.6.4 of the IGC Code are to be fitted are to be intended as the loading and unloading manifolds.

4.2.2 Fail-close action of Emergency Shut Down (ESD) valve (1/1/2024)

IGC CODE REFERENCE : Ch 5, 5.6.4

The following requirements specify the arrangements for emergency shut down valve (hereinafter referred to as ESD valve) installed in cargo piping of ships engaged in the carriage of liquefied gases to stop cargo flow in the event of an emergency, either internally within the ship, or during cargo transfer to other ships or shore facilities.

When ESD valve is actuated by hydraulic or pneumatic system, the following are to be complied with:

- a) audible and visible alarm is to be given in the event of loss of pressure that causes activation of fail-close action. The alarm is to be provided in a normally manned control station (e.g. Cargo Control Room and/or the navigation bridge, etc.).
- b) the following conditions are also to be complied to ensure the fail-close action:
 - 1) failure of hydraulic or pneumatic system is not to lead to loss of fail-close functionality (i.e. activated by spring or weight); or
 - 2) hydraulic or pneumatic system for fail-close action is to be arranged with stored power and separated from normal valve operation.

5 Cargo transfer methods

5.1 Discharge into common header

5.1.1 -

IGC CODE REFERENCE : Ch 5, 5.8

When two or more pumps located in different cargo tanks are operating at the same time discharging into a common header, the stopping of the pumps is to activate an alarm at the centralised cargo control location.

6 Bonding

6.1 Static electricity

6.1.1 Acceptable resistance -

IGC CODE REFERENCE : Ch 10, 10.3

To avoid the hazard of an incentive discharge due to the build-up of static electricity resulting from the flow of the liquid/gases/vapours, the resistance between any point on the surface of the cargo and slop tanks, piping systems and equipment, and the hull of the unit is not to be greater than $10^6 \Omega$.

6.1.2 Bonding straps -

IGC CODE REFERENCE : Ch 10, 10.3

Bonding straps are required for cargo and slop tanks, piping systems and equipment which are not permanently connected to the hull of the unit, for example:

- a) independent cargo tanks
- b) cargo tank piping systems which are electrically separated from the hull of the unit
- c) pipe connections arranged for the removal of the spool pieces
- d) all process vessels and piping supported on insulated shock mountings
- e) all process equipment mounted on non-conducting anti-vibration chocks
- f) all electric motors associated with hydrocarbon production and handling located external to the cargo tanks.

Where bonding straps are required, they are to be:

- a) clearly visible so that any shortcoming can be easily detected
- b) designed and sited so that they are protected against mechanical damage and are not affected by high resistivity contamination, e.g. corrosive products or paint
- c) easy to install and replace.

7 Integrated cargo and ballast system

7.1 General

7.1.1 -

The requirements for integrated cargo and ballast systems are given in Part C, Chapter 5.

SECTION 6

MATERIALS FOR CONSTRUCTION

1 Material requirements

1.1 Tubes, forgings and castings for cargo and process piping

1.1.1 -

IGC CODE REFERENCE: Ch 6, Table 6.4

In general, impact tests for forgings, castings and welded and seamless pipes in stainless austenitic grades 304, 304L, 316, 316L, 321 and 347 are required when the design temperature is below -105°C and are to be carried out at -196°C.

1.2 Aluminium coatings

1.2.1 -

IGC CODE REFERENCE : Ch 6, 6.2

The use of aluminium coatings is prohibited in the cargo tanks, cargo tank deck area, pump rooms, cofferdams or any other area where cargo gas may accumulate.

2 Welding and non-destructive testing

2.1 Welding consumables

2.1.1 -

IGC CODE REFERENCE : Ch 6, 6.3.2

The content of paragraph 6.3.2 of the IGC Code is also to cover process pressure vessels and secondary barriers.

2.2 Test requirements

2.2.1 Bend tests -

IGC CODE REFERENCE : Ch 6, 6.3.4.2

As an alternative to the bend test indicated in paragraph 6.3.4.2 of the IGC Code, a test over a mandrel having a diameter equal to 3 times the thickness with a bend angle up to 120° may be required.

SECTION 7

CARGO PRESSURE/TEMPERATURE CONTROL

1 Cargo Pressure/Temperature Control

1.1 General

1.1.1 -

The cargo pressure/temperature control is to comply with Chapter 7 of the IGC Code and with the following requirements.

2 Additional requirements for refrigerating plants

2.1

2.1.1 -

IGC CODE REFERENCE : Ch 7, 7.2

In general, in addition to the requirements of 7.2 of the IGC Code, refrigerating plants are to comply with the provisions of Pt C, Ch 1, Sec 4 of the Rules for the Classification of Ships.

3 Reliquefaction plant of FSRU

3.1 Mechanical refrigeration fitted as the primary system for cargo pressure control

3.1.1 General -

IGC CODE REFERENCE : Ch 7, 7.2

Paragraph 7.2 of the IGC Code relative to refrigerating systems is based on the assumption that maintenance of the cargo pressure described in 7.1 of the IGC Code is complied with by using means defined in 7.1.1.1 of the Code. That is to say, a mechanical refrigeration system is fitted as the primary means of maintaining the cargo tank pressure below MARVS.

3.1.2 Standby refrigerating units -

IGC CODE REFERENCE : Ch 7, 7.2

Paragraph 7.2 of the IGC Code is to apply to refrigeration systems fitted on FSRUs, i.e. the standby capacity required is to be as detailed in 7.2.1 of the IGC Code. A standby LNG/refrigerant heat exchanger need not be provided and the fitted LNG/refrigerant heat exchanger is not required to have 25% excess capacity over that for normal requirements. Other heat exchangers utilising water cooling are to have a standby or to have at least 25% excess capacity.

3.1.3 Alternative means for cargo pressure/temperature control -

IGC CODE REFERENCE : Ch 7, 7.2

Paragraph 7.2.1 of the IGC Code states that unless an alternative means of controlling the cargo pressure/temperature is provided to the satisfaction of the Administration, a

standby unit (or units) affording spare capacity at least equal to the largest required single unit is (are) to be fitted.

For the purpose of complying with the above, a suitable alternative means of pressure/temperature control would be:

- a) boiler(s) capable of burning the boil-off vapours and disposing of the generated steam or an alternative waste heat system acceptable to the Society. Consideration will be given to systems burning only part of the boil-off vapour if it can be shown that MARVS will not be reached within a period of 21 days.
- b) reinjection of the boil-off gases into the liquefaction train,
- c) use of the boil-off gases as fuel for the prime movers involved in the process systems,
- d) possible use of LPG gases as an alternative liquefaction plant refrigerant source
- e) controlled venting of cargo vapours as specified in paragraph 7.1.1.5 of the IGC Code if permitted by the Administration concerned.

3.2 Mechanical refrigeration fitted as a secondary system for cargo pressure control

3.2.1 -

IGC CODE REFERENCE : Ch 7, 7.2

Where a refrigeration plant is fitted as a means of disposing of excess energy as detailed in the second sentence of 7.1.1.2, no standby unit will be required for the refrigeration plant.

4 Cargo Compressor Systems

4.1 Cargo compressors

4.1.1 General -

For an FLNG unit which has large amounts of machinery located within the process area it may not be necessary to locate cargo compressors within a dedicated compressor room.

The number of compressors will depend upon the type of fluids to be handled and they are to be of sufficient capacity to handle the volume of boil-off gas generated under normal operating conditions. In general these compressors are to be arranged whereby the failure of one compressor will not affect the capacity of the system to maintain the cargo tank pressure and temperature.

The control of the gas compressors is governed mainly by the cargo tank pressure and protective devices are to be installed on the compressors to prevent the cargo tank pres-

sure being lowered to a value below the design pressure for the relevant tanks.

An FLNG unit may require additional high capacity and high pressure compressors to handle the boil-off gases returned from the off-taking vessel during LNG transfer. These may be the compressors used to handle the natural boil-off gases from the LNG storage tanks or additional compressors installed for specific use during high BOG handling situations.

4.2 Cargo Compressor Drives

4.2.1 -

Where drives are integral with or located in the same space as the compressor, i.e. in a hazardous zone, then those drives must comply with all regulations for that zone.

Where compressors are driven by a machine which is located outside the compressor room, the following arrangements are to be made:

- a) Drive shafts are to be fitted with flexible couplings or other means suitable to compensate for any misalignment.
- b) The shaft bulkhead or deck penetration is to be fitted with a gas-tight gland of a type approved by the Society. The gland is to be efficiently lubricated from outside the compressor room and so designed as to prevent overheating. The seal parts of the gland are to be of material that cannot initiate sparks.
- c) Temperature sensing devices are to be fitted for the bulkhead shaft gland.

5 Oxidation Systems

5.1

5.1.1 -

Oxidation systems are systems whereby boil-off vapours are utilised as shipboard fuel, in a boiler to generate steam, in an internal combustion engine as a second/alternative fuel or are disposed of via a thermal oxidiser or a gas combustion unit. In any of these cases where gas compressors are required to direct the boil-off vapours to the particular oxidiser in question the requirements of these compressors are covered in [4].

6 Venting and Flaring

6.1 General

6.1.1 -

If in normal operation it is found that cargo storage tank pressure or temperature is rising above acceptable values either with the normal gas handling plant at full capacity or out of commission then the possibility of venting the tank to atmosphere through a venting or flaring system can be considered. In normal operation this should be considered as a last resort for storage tank pressure and temperature control. A design based on continuous flaring is not acceptable.

The regulations for the siting and construction of flares and cold vents are given in Pt C, Ch 6, Sec 2.

SECTION 8

CARGO TANK AND PROCESS VENTING SYSTEM

1 Pressure relief systems

1.1 Hydrocarbon storage tanks

1.1.1 -

The pressure relief system for the LPG and LNG storage tanks is to comply with IGC CODE Ch 8.

The pressure relief system for the light liquid hydrocarbons (condensate) separated from the feed gas storage tanks is to comply with Pt E, Ch 1 of these Rules.

1.2 Process vessels

1.2.1 -

All process vessels handling gaseous or liquid hydrocarbons under pressure are to be fitted with suitable pressure relief devices that are connected to a common disposal system routing the relieved hydrocarbons to flare or vent.

The safe disposal by flaring of hydrocarbon gas released due to an overpressure or other upset condition is to be taken into consideration in the design of the system. However, the process systems are to be closed systems. Accordingly, continuous flaring is not an acceptable design premise.

1.3 Interbarrier spaces

1.3.1 Protection of interbarrier spaces - IGC CODE

REFERENCE : Ch 8, 8.2.2

- The formula for determining the relieving capacity given in paragraph 8.3.2 of the IGC Code is developed for interbarrier spaces surrounding independent type A cargo tanks, where the thermal insulation is fitted to the cargo tanks.
- The relieving capacity of pressure relief devices of interbarrier spaces surrounding independent type B cargo tanks may be determined on the basis of the method given in paragraph 8.2 of the IGC Code; however, the leakage rate is to be determined in accordance with 4.7.6.1 of the IGC Code.
- The relieving capacity of pressure relief devices for interbarrier spaces of membrane and semi-membrane tanks is to be evaluated on the basis of specific membrane/semi-membrane tank design.
- The relieving capacity of pressure relief devices for interbarrier spaces adjacent to integral type cargo tanks may, if applicable, be determined as for type A independent cargo tanks.
- Interbarrier space pressure relief devices in the scope of this interpretation are emergency devices for protecting the hull structure from being unduly overstressed in the event of a pressure rise in the interbarrier space due to primary barrier failure. Therefore such devices need not comply with the requirements of paragraphs 8.2.9 of the IGC Code.

1.3.2 Size of pressure relief devices -

IGC CODE REFERENCE : Ch 8, 8.2.2

The combined relieving capacity (in m³/s) of the pressure relief devices for interbarrier spaces surrounding type A independent cargo tanks where the insulation is fitted to the cargo tanks may be determined by the following formula:

$$Q_{sa} = 3,4 \cdot A_C \cdot \frac{\rho}{\rho_V} \cdot \sqrt{h}$$

where:

Q_{sa} : Minimum required discharge rate of air in standard conditions of 273 K and 0,1013 MPa

A_C : Design crack opening area in (m²)

$$A_C = \frac{\pi}{4} \cdot \delta \cdot l$$

with:

δ : Max. crack opening width in (m)

$$\delta = 0,2 \cdot t$$

t : Thickness of tank bottom plating in (m)

l : Design crack length in (m) equal to the diagonal of the largest plate panel of the tank bottom (see Fig 1)

h : Max. liquid height above tank bottom plus 10 × MARVS in (m)

ρ : Density of product liquid phase in t/m³ at the set pressure of the interbarrier space relief device

ρ_V : Density of product vapour phase in t/m³ at the set pressure of the interbarrier space relief device and a temperature of 273 K.

1.4 Vents

1.4.1 Vents of LPG and LNG storage tanks -

IGC CODE REFERENCE : Ch 8, 8.2.9

The height of vent exits as indicated in paragraph 8.2.9 of the IGC Code is also to be measured above storage tanks and cargo liquid lines, where applicable.

1.5 Segregation of vents

1.5.1 Additional requirements on vent location -

IGC CODE REFERENCE : Ch 8, 8.2.10

- The distances of the vent exits are to be measured horizontally.
- In the case of carriage of flammable and/or toxic products, the vent exits are to be arranged at a distance of at least 5 m from exhaust ducts and at least 10 m from intake ducts serving cargo pump rooms and/or cargo compressor rooms.
- The distances are also intended to refer to outlets of ventilation ducts of safe spaces.

1.6 Back pressure

1.6.1 Pressure drop in vent lines -

IGC CODE REFERENCE : Ch 8, 8.2.16

Where a number of relief devices are connected into a common relief header then the back pressure build-up that may be caused by a number of relief devices opening at the same time must under no circumstance affect the ability of the relief devices to protect the vessel to which they are fitted.

The pressure drop in the vent line from the tank to the pressure relief valve inlet is not to exceed 3% of the valve set pressure. For unbalanced pressure relief valves the back pressure in the discharge line is not to exceed 10% of the gauge pressure at the relief valve inlet with the vent lines under fire exposure.

2 Additional pressure relieving system for liquid level control

2.1 General

2.1.1 Additional pressure relieving system -

IGC CODE REFERENCE : Ch 8, 8.3.1.2

The override arrangement indicated in paragraph 8.3.1.2 of the IGC Code is to be capable of being manually operated. As an alternative, means for manual venting are to be provided.

2.1.2 Tank filling limits -

IGC CODE REFERENCE : Ch 8, 8.3.1

The words 'to prevent the tank from becoming liquid full' in paragraph 8.3.1 of the IGC Code have the following meaning.

At no time during the loading, transport or unloading of the cargo including fire conditions will the tank be more than 98% liquid full, except as permitted by 15.1.3 of the IGC Code. These requirements, together with those of 8.2.17 of the IGC Code, are intended to ensure that the pressure relief valves remain in the vapour phase.

Figure 1 : Determination of l -

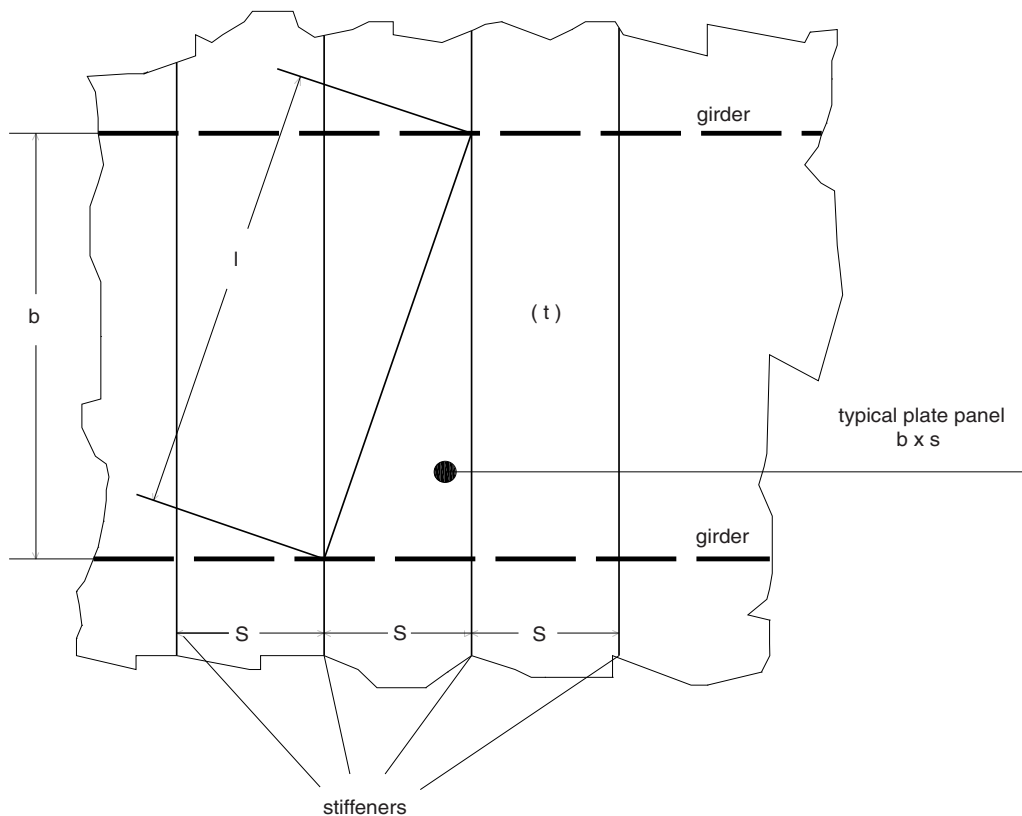

SECTION 9

ENVIRONMENTAL CONTROL

1 Cargo storage tanks and piping environmental control

1.1 General

1.1.1 -

The environmental control for tanks containing liquefied gaseous hydrocarbons and relevant piping is to comply with IGC CODE Ch 9 [9.1], [9.2] and [9.3].

The environmental control for tanks containing light liquid hydrocarbons (condensate) separated from the feed gas is to comply with Pt E Ch 1 of these Rules.

2 Inerting

2.1 General

2.1.1 Dew point -

IGC CODE REFERENCE : Ch 9, 9.4.1

As far as the IGC Code requirements relevant to the dew point are concerned, the following additional provisions apply:

- a) where cargo tank insulation is not protected from water vapour penetration by means of an effective vapour barrier, accepted by the Society, the maximum value of the dew point is to be less than the design temperature
- b) where cargo tank insulation is protected by an effective vapour barrier, accepted by the Society, the maximum value of the dew point is to be less than the minimum temperature which may be found on any surface within the spaces filled with dry inert gas or dry air
- c) the temperature of the hull structures adjacent to cargo tanks is not to become lower than the minimum permissible working temperature, specified in Section 6, for the steel grade employed for such hull structures.

2.1.2 Precautions against fire -

IGC CODE REFERENCE : Ch 9, 9.4.1

Precautions are to be taken to minimise the risk that static electricity generated by the inert gas system may become a source of ignition.

3 Inert gas production on board

3.1 General

3.1.1 -

Inert gas plant producing inert gas for the environmental control for tanks containing liquefied gaseous hydrocarbons and relevant piping is to comply with IGC CODE Ch 9 [9.5].

Inert gas plant producing inert gas for the environmental control for tanks containing light liquid hydrocarbons (condensate) separated from the feed gas is to comply with Pt E Ch 1 of these Rules.

3.2 Exemptions

3.2.1 -

- a) Inert gas generating systems are to be considered as essential services and are to comply with the applicable Sections of the Rules, as far as applicable.
- b) Where, in addition to inert gas produced on board, it is possible to introduce dry air into the above-mentioned spaces, where this is acceptable depending on the type of cargo tank adopted, or to introduce inert gas from a supply existing on board, it is not necessary that standby or spare components for the inert gas system are kept on board.

4 Inerting of liquefaction process vessels and piping

4.1 General

4.1.1 -

Inert gas produced by combustion methods may not always be compatible with the fluids involved in the liquefaction process, from the treatment of the incoming feed gas to the final production of LNG. For this purpose, it may be necessary to produce on board an inert gas compatible with all fluids, in general nitrogen.

4.2 Nitrogen generators

4.2.1 -

Nitrogen generators are to comply with the following requirements.

- a) The nitrogen generator package may be installed in the engine room or in a separate compartment. It may be installed within the process area if suitably classified for the zone.
- b) The vents from the nitrogen generators are to be separated from those containing hydrocarbons. The vents from the nitrogen generator and nitrogen system relief valves are to be led to a safe location, in general not less than 3,0 m from personnel and ventilation intakes.
- c) Spaces containing nitrogen systems are to be fitted with ventilation systems ensuring at least 30 changes per hour and a gas detection system.
- d) A low oxygen alarm is also to be fitted. The compartment is to have no direct access to accommodation spaces, service spaces and control stations.

- e) The nitrogen generator is to be capable of delivering high purity nitrogen with O₂ content not exceeding 5% by volume. The system is to be fitted with automatic means to discharge off-specification gas to the atmosphere during start-up and abnormal operation.
- f) The system is to be provided with two air compressors. The total required capacity of the system is preferably to be divided equally between the two compressors, and in no case is one compressor to have a capacity less than 1/3 of the total capacity required. Only one air compressor may be accepted provided that sufficient spares for the air compressor and its prime mover are carried on board to enable their failure to be rectified by the ship's crew.
- g) A feed air treatment system is to be fitted to remove free water, particles and traces of oil from the compressed air, and to preserve the specification temperature.
- h) The oxygen-enriched air from the nitrogen generator and the nitrogen-product enriched gas from the protective devices of the nitrogen receiver are to be discharged to a safe location on the open deck.
- i) In order to permit maintenance, means of isolation are to be fitted between the generator and the receiver.
- j) At least two non-return devices are to be fitted in the inert gas supply main, one of which is to be of the double block and bleed arrangement. The second non-return device is to be equipped with positive means of closure.
- k) Instrumentation is to be provided for continuously indicating the temperature and pressure of air:
 - 1) at the discharge side of the compressor,
 - 2) at the entrance side of the nitrogen generator.
- l) Instrumentation is to be fitted for continuously indicating and permanently recording the oxygen content of the inert gas downstream of the nitrogen generator when inert gas is being supplied.
- m) The instrumentation referred to in the preceding item l) is to be placed in the process control room, where provided. But where no process control room is provided, it is to be placed in a position easily accessible to the officer in charge of process operations.
- n) Audible and visual alarms are to be provided to indicate:
 - 1) low feed air pressure from compressor as referred to in k)1) above
 - 2) high air temperature as referred to in k)1) above
 - 3) high condensate level at automatic drain of water separator as referred to in item g) above
 - 4) failure of electric heater, if fitted
 - 5) oxygen content in excess of that required in item e) above
 - 6) failure of power supply to the instrumentation as referred to in item l) above.
- o) Automatic shutdown of the system is to be arranged upon alarm conditions as required by items n) 1) to 5) above.
- p) The alarms required by items n) 1) to 6) above are to be fitted in the process control room, where provided, but in each case in such a position that they are immediately received by responsible members of the crew.

SECTION 10

ELECTRICAL INSTALLATIONS

1 General

1.1 Application

1.1.1 -

The requirements in this Section apply to FLNG units in addition to those contained in Part C, Chapter 2.

1.2 Definitions

1.2.1 -

Source of release: point or location from which a flammable gas, vapour, or liquid may be released into the atmosphere in such a way that an explosive gas atmosphere could be formed.

1.2.2 (1/1/2021)

Grades of release: the likelihood of the presence of an explosive gas atmosphere, and hence the type of zone, depends mainly on the following grade of release:

- a) continuous grade;
- b) primary grade;
- c) secondary grade.

A continuous grade of release normally leads to a zone 0, a primary grade to zone 1 and a secondary grade to zone 2 (see Note 1).

Note 1: The availability and degree of ventilation do influence the extent of the zone and might even lead to a higher or lower risk zone.

1.2.3 -

Continuous grade of release: release which is continuous or is expected to occur frequently or for long periods.

1.2.4 -

Primary grade of release: release which can be expected to occur periodically or occasionally during normal operation.

1.2.5 -

Secondary grade of release: release which is not expected to occur in normal operation and, if it does occur, is likely to do so only infrequently and for short periods.

1.2.6 -

Release rate: quantity of flammable gas or vapour emitted per unit time from the source of release.

1.3 Monitoring of circuits in hazardous areas

1.3.1 (1/1/2021)

The device intended to continuously monitor the insulation level of all distribution systems is also to monitor all circuits, other than intrinsically safe circuits, connected to apparatus in hazardous areas or passing through such areas.

An audible and visual alarm is to be given, at a manned position, in the event of an abnormally low level of insulation.

1.4 Precautions against inlet of gases or vapours

1.4.1 -

Suitable arrangements are to be provided, to the satisfaction of the Society, so as to prevent the possibility of gases or vapours passing from a gas-dangerous space to another space through runs of cables or their conduits.

2 Hazardous location classification and permitted electrical equipment

2.1 General

2.1.1 -

Units are to be assessed with regard to any potential explosive gas atmosphere in accordance with the provisions of [2] or alternatively with an acceptable code or standard giving equivalent safety.

2.1.2 -

The results are to be documented in area classification drawings to allow the proper selection of all electrical components to be installed.

2.1.3 -

The hazardous location classification is to be carried out by those who have knowledge of the properties of flammable materials, the process and the equipment, in consultation with, as appropriate, safety, electrical, mechanical and other engineering personnel.

2.1.4 -

Classification of hazardous areas in ZONES is defined in Pt C, Ch 2, Sec 1, [3.24] of the Rules for the Classification of Ships.

2.1.5 -

Release as a result of accidental events such as blow-out or vessel rupture is not addressed by area classification. It is to be covered by emergency measures.

2.1.6 -

Openings, penetrations or connections between areas of different hazardous area classification are to be avoided, e.g. through ventilation systems, air pipes or drain systems.

2.1.7 -

Enclosed or semi-enclosed spaces (not containing a source of hazard) having a direct opening, including those for ventilation, into any hazardous area are to be designated as the same hazardous zone as the area in which the opening is located. See also [2.1.6] and [2.1.9]. Electrical installations

are to comply with the requirements for the space or area into which the opening leads.

2.1.8 -

Electrical installations in spaces protected by air locks are to be of a certified safe type unless arranged to be de-energised upon loss of overpressure in the space.

2.1.9 (1/1/2021)

Except for operational reasons, access doors or other openings are not to be provided between a non-hazardous space and a hazardous area or between a zone 2 space and a zone 1 space. Where such access doors or other openings are provided, any non-hazardous enclosed space having direct access to any zone 1 location or zone 2 location becomes the same zone as the location except that:

- a) an enclosed space with direct access to any zone 1 location can be considered as zone 2 if:
 - the access is fitted with a self-closing gas-tight door opening into the zone 2 space, and
 - ventilation is such that the air flow with the door open is from the zone 2 space into the zone 1 location, and
 - loss of ventilation is alarmed at a manned station;
- b) an enclosed space with direct access to any zone 2 location is not considered hazardous if:
 - the access is fitted with a self-closing gas-tight door that opens into the non-hazardous location, and
 - ventilation is such that the air flow with the door open is from the non-hazardous space into the zone 2 location, and
 - loss of ventilation is alarmed at a manned station.

For safety reasons doors are to be normally opened outwards.

- c) an enclosed space with direct access to any zone 1 location is not considered hazardous if:
 - the access is fitted with two self-closing gas-tight doors forming an air lock, and
 - the space has ventilation overpressure in relation to the hazardous space (see Note 1), and
 - loss of ventilation overpressure is alarmed at a manned station (see Note 1), and
 - the ventilation system shall be designed to maintain at least 50 Pa overpressure with respect to the external hazardous area when all penetrations are closed.

Note 1: An alarm delay of up to 30 s for loss of overpressure may be applied to minimize spurious alarms when doors are intentionally opened.

2.1.10 -

Where ventilation arrangements for the intended safe space are considered sufficient by the Society to prevent any ingress of gas from the zone 1 location, the two self-closing doors forming an air-lock may be replaced by a single self-closing gas-tight door which opens into the non-hazardous location and has no hold-back device.

2.1.11 -

Piping systems are to be designed to preclude direct communication between hazardous areas of different classifications and between hazardous and non-hazardous areas.

2.2 Ventilation

2.2.1 -

For requirements of ventilation systems in hazardous areas, see Ch 3, Sec 12.

2.3 Hazardous area and electrical equipment

2.3.1 -

Electrical installations are to be such as to minimise the risk of fire and explosion from flammable products.

2.3.2 -

Electrical equipment and cables installed in hazardous areas are to be limited to those necessary for operational purposes.

2.3.3 -

Where electrical equipment is installed in gas-dangerous spaces or zones and is essential for operational purposes, it should be of a safe type for operation in the flammable atmosphere concerned.

2.3.4 -

Portable electrical equipment supplied by cables is not permitted in hazardous areas, unless special precautions are taken (see IEC 61892-7 clause 6.5).

2.3.5 -

For FLNG the electrical equipment specified in Tab 1 may be installed in gas-dangerous spaces and areas indicated therein.

2.3.6 -

Tab 2 specifies temperature class and explosion group data for some products. The data shown in brackets have been derived from similar products.

2.3.7 -

For electrical cables see Pt C, Ch 2, Sec 2, [12.2].

2.3.8 -

The cross-section of cables installed in hazardous areas is to be correlated to the time/current characteristics of the relevant electrical protective device in order to limit the surface temperature of the cable to a safety value required by the temperature class of the dangerous gas likely to be present in the area, under the most severe expected fault condition.

2.3.9 -

Submerged cargo pumps are not permitted in connection with the following cargoes:

- diethyl ether;
- vinyl ethyl ether;
- ethylene oxide;
- propylene oxide;
- mixtures of ethylene oxide and propylene oxide.

2.3.10 -

- a) Where submerged electric motors are employed, means are to be provided, e.g. by the arrangements specified in paragraph 17.6 of the IGC Code, to avoid the formation of explosive mixtures during loading, cargo transfer and unloading.
- b) Arrangements are to be made to automatically shut down the motors in the event of low liquid level. This

may be accomplished by sensing low pump discharge pressure, low motor current, or low liquid level. This shutdown is to be alarmed at the cargo control station. Cargo pump motors are to be capable of being isolated from their electrical supply during gas-freeing operations.

2.4 Process plant location classification and permitted electrical equipment

2.4.1 (1/1/2021)

Hazardous location classification is to be carried out in accordance with the following requirements and IEC 60079-10-1, or, alternatively, with an acceptable code or standard giving equivalent safety.

2.4.2 -

It is to be taken into consideration that the horizontal extent of the hazardous areas at ground level will increase with increasing relative density of the gas or vapour which may be released and the vertical extent above the source will increase with decreasing gas or vapour relative density.

2.4.3 -

Zone 0 hazardous location normally include areas or spaces:

- a) within process apparatus developing flammable gas or vapours;
- b) within enclosed pressure vessels or storage tanks;
- c) around vent pipes which discharge continually or for long periods;
- d) over/near surface of flammable liquids in general;
- e) areas inside atmospheric pressure vessels.

The zone 0 area referred to in a), b) and d) above is only applicable for equipment vented to the atmosphere.

2.4.4 (1/1/2021)

Zone 1 hazardous location normally include areas or spaces:

- a) with a certain radius around the outlet of vent and pressure relief valves venting to atmosphere of pressurized vessels containing hydrocarbon;
- b) around ventilation openings from a zone 1 area;
- c) around sample taking points (valves, etc.);
- d) around seals of pumps, compressors, and similar apparatus, if primary source of release and rooms without ventilation, with direct access from a zone 2 area;
- e) rooms or parts of rooms containing secondary sources of release, where internal outlets indicate zone 2, but where efficient dilution of an explosive atmosphere cannot be expected because of insufficient ventilation.

2.4.5 -

Zone 2 hazardous location normally include areas or spaces:

- a) around flanges, connections, valves, etc.;
- b) outside of zone 1, around the outlet of vent pipes, pipelines and safety valves;
- c) around vent openings from the zone 2 area;
- d) between the main deck and the production/facilities deck, unless installations on the deck result in a zone 1 area classification.

2.4.6 (1/1/2021)

The following provisions are to be taken into account.

- a) Pipelines without flanges, connections, valves or other similar fittings need not be regarded as a source of release.
- b) Certain areas and spaces (rooms) are, if so indicated by the circumstances, to be classified as a more hazardous zone than set out in these examples.
- c) Certain areas and spaces (rooms) may, under certain circumstances and/or when special precautions are taken, be classified as a less hazardous zone than indicated by these examples. Such special circumstances may be, for example, redundant ventilation arrangements.
- d) Enclosed rooms, without ventilation, with openings to an area with explosion risks are to be classified as the same, or as a more hazardous zone than such an area.

2.4.7 -

Electrical installations are to be such as to minimise the risk of fire and explosion from flammable products.

2.4.8 -

Electrical equipment and cables installed in hazardous areas are to be limited to those necessary for operational purposes.

2.4.9 -

Where electrical equipment is installed in gas-dangerous spaces or zones and is essential for operational purposes, it should be of a safe type for operation in the flammable atmosphere concerned.

2.4.10 -

Portable electrical equipment supplied by cables is not permitted in hazardous areas, unless special precautions are taken (see IEC 61892-7 clause 6.5).

2.4.11 -

Permitted electrical equipment in hazardous location defined according to Ch 3, Sec 10, [2.4] is that indicated in Pt C, Ch 2, Sec 2, [12.1.4] to [12.1.6] as applicable.

2.4.12 -

The explosion group and temperature class of electrical equipment of a certified safe type are to be chosen taking into account the most demanding of the required explosion groups and temperature classes of the hazardous product whose gas or vapour may be present at the location.

2.4.13 -

For electrical cables see Pt C, Ch 2, Sec 2, [12.2].

2.4.14 -

The cross-section of cables installed in hazardous areas is to be correlated to the time/current characteristics of the relevant electrical protective device in order to limit the surface temperature of the cable to a safety value required by the temperature class of the dangerous gas likely to be present in the area, under the most severe expected fault condition.

3 Sources of electrical power and distribution systems

3.1 Power source location

3.1.1 (1/1/2021)

Sources of electrical power and their main/emergency switchboards and distribution boards, are, to the extent possible, not be located in hazardous areas.

3.1.2 (1/1/2021)

The generating plant, switchboards and batteries are to be separated from any zone 0 by cofferdams or equivalent spaces and from other hazardous areas by gas-tight steel divisions or in areas protected by overpressure.

Access between such spaces is to comply with [2.1.9]

Table 1 : FLNG hazardous location classification and permitted electrical equipment -

Hazardous area	Spaces		Electrical equipment
	N°	Description	
Zone 0	1	Cargo containment systems: Interior of cargo tanks, slop tanks, any pipework of pressure relief or other venting systems for cargo and slop tanks, pipes and equipment containing cargo or developing flammable gases or vapours. Gas Processing and Liquefaction facility	<ul style="list-style-type: none"> a) certified intrinsically safe apparatus Ex(ia); b) simple electrical apparatus and components (e.g. thermocouples, photocells, strain gauges, switching devices), included in intrinsically safe circuits of category "ia" not capable of storing or generating electrical power or energy in excess of limits stated in the relevant standards c) equipment specifically designed and certified by the appropriate authority for use in Zone 0 d) submerged cargo pump motors and their supply cables may be fitted in cargo containment systems.
Zone 0	2	Interbarrier spaces, hold spaces where cargo is carried in a cargo containment system requiring a secondary barrier.	<ul style="list-style-type: none"> a) certified intrinsically safe apparatus Ex(ia); b) simple electrical apparatus and components (e.g. thermocouples, photocells, strain gauges, switching devices), included in intrinsically safe circuits of category "ia" not capable of storing or generating electrical power or energy in excess of limits stated in the relevant standards; c) equipment specifically designed and certified by the appropriate authority for use in Zone 0; d) supply cables for submerged cargo pump motors.

Hazardous area	Spaces		Electrical equipment
	N°	Description	
Zone 1	3	Hold spaces where cargo is carried in a cargo containment system not requiring a secondary barrier	<ul style="list-style-type: none"> a) any type considered for Zone 0; b) certified intrinsically safe apparatus Ex(ib); c) simple electrical apparatus and components (e.g. thermocouples, photocells, strain gauges, switching devices), included in intrinsically safe circuits of category "ib" not capable of storing or generating electrical power or energy in excess of limits stated in the relevant standards; d) electrical cables passing through the spaces; e) lighting fittings are to have pressurised enclosures Ex(p) or to be of the flameproof type Ex(d). The lighting system is to be divided between at least two branch circuits. All switches and protective devices are to interrupt all poles or phases and are to be located in a gas-safe space; f) hull fittings containing the terminals or shell plating penetrations for anodes or electrodes of an impressed current cathodic protection system, or transducers such as those for depth sounding or log systems, provided that such fittings are of gas-tight construction or housed within a gas-tight enclosure and are not located adjacent to a cargo tank bulkhead. The design of such fittings or their enclosures and the means by which cables enter, and any testing to establish their gas-tightness, are to be to the satisfaction of the Society.
Zone 1	4	Spaces separated from a hold space where cargo is carried in a cargo containment system requiring a secondary barrier by a single gas-tight steel boundary.	<ul style="list-style-type: none"> a) any type considered for spaces under item 3; b) flameproof motors for valve operation for cargo or ballast systems; c) flameproof general alarm audible indicators.

Hazardous area	Spaces		Electrical equipment
	N°	Description	
Zone 1	5	Cargo pump rooms and cargo compressor rooms, if fitted, or rooms designated as cargo machinery spaces.	<p>a) any type considered for Zone 0;</p> <p>b) certified intrinsically safe apparatus Ex(ib);</p> <p>c) simple electrical apparatus and components (e.g. thermocouples, photocells, strain gauges, switching devices), included in intrinsically safe circuits of category “ib” not capable of storing or generating electrical power or energy in excess of limits stated in the relevant standards;</p> <p>d) lighting fittings are to have pressurised enclosures Ex(p) or to be of the flameproof type Ex(d). The lighting system is to be divided between at least two branch circuits. All switches and protective devices are to interrupt all poles or phases and are to be located in a gas-safe space;</p> <p>e) electric motors for driving cargo pumps or cargo compressors are to be separated from these spaces by a gas-tight bulkhead or deck. Flexible couplings or other means of maintaining alignment are to be fitted to the shafts between the driven equipment and its motors and, in addition, suitable glands are to be provided where the shafts pass through the bulkhead or deck. Such electric motors and associated equipment are to be located in a compartment complying with Chapter 12 of the IGC Code;</p> <p>f) where operational or structural requirements are such as to make it impossible to comply with the method described in e), motors of the following certified safe types may be installed:</p> <ul style="list-style-type: none"> • increased safety type with flameproof enclosure Ex(de); and • pressurised type; <p>g) certified safe type visual and/or acoustic indicators (e.g. for general alarm, fire-extinguishing media alarm, etc.);</p> <p>h) certified safe type sensors for gas detection systems.</p>
Zone 1	6	Areas on open deck or semi-enclosed spaces on open deck, within 3 m of any cargo tank outlet, gas or vapour outlet, cargo manifold valve, cargo valve, cargo pipe flange, cargo pump room and cargo compressor room, ventilation outlets and cargo tank openings for pressure release provided to permit the flow of small volumes of gas or vapour mixtures caused by thermal variation.	<p>a) any type considered for Zone 0;</p> <p>b) certified intrinsically safe apparatus Ex(ib);</p> <p>c) simple electrical apparatus and components (e.g. thermocouples, photocells, strain gauges, switching devices), included in intrinsically safe circuits of category “ib” not capable of storing or generating electrical power or energy in excess of limits stated in the relevant standards;</p> <p>d) certified flameproof Ex(d);</p> <p>e) certified pressurised Ex(p);</p> <p>f) certified increased safety Ex(e);</p> <p>g) certified encapsulated Ex(m);</p> <p>h) certified sand filled Ex(q);</p> <p>i) electrical cables passing through the spaces.</p>
Zone 1	7	Areas on open deck, or semi-enclosed spaces on open deck above and in the vicinity of any cargo gas outlet intended for the passage of large volumes of gas or vapour mixture during cargo loading and ballasting or during discharging, within a vertical cylinder of unlimited height and 6 m radius centred upon the centre of the outlet, and within a hemisphere of 6 m radius below the outlet.	As allowed under item 6.

Hazardous area	Spaces		Electrical equipment
	N°	Description	
Zone 1	8	Areas on open deck, or semi-enclosed spaces on open deck within 1,5 m of cargo pump room entrances, cargo pump room ventilation inlet, openings into cofferdams or other zone 1 spaces.	As allowed under item 6.
Zone 1	9	Areas on open deck within spillage coamings surrounding cargo manifold valves and 3 m beyond these, up to a height of 2,4 m above the deck.	As allowed under item 6.
Zone 1	10	Areas on open deck over all cargo tanks (including all ballast tanks within the cargo tank area) where structures are restricting the natural ventilation and to the full breadth of the unit plus 3 m fore and aft of the forward-most and aft-most cargo tank bulkhead, up to a height of 2,4 m above the deck.	As allowed under item 6.
Zone 1	11	Compartments for cargo hoses.	<ul style="list-style-type: none"> a) any type considered for Zone 0; b) certified intrinsically safe apparatus Ex(ib); c) simple electrical apparatus and components (e.g. thermocouples, photocells, strain gauges, switching devices), included in intrinsically safe circuits of category "ib" not capable of storing or generating electrical power or energy in excess of limits stated in the relevant standards; d) lighting fittings are to have pressurised enclosures Ex(p) or to be of the flameproof type Ex(d). The lighting system is to be divided between at least two branch circuits. All switches and protective devices are to interrupt all poles or phases and are to be located in a gas-safe space; e) electrical cables passing through the spaces.
Zone 1	12	Enclosed or semi-enclosed spaces in which pipes containing cargoes are located.	As allowed under item 11.
Zone 2	13	Areas of 1,5 m surrounding open or semi-enclosed spaces of Zone 1 defined in item 6, 7, 9 and 10	<ul style="list-style-type: none"> a) any type considered for Zone 1; b) electrical equipment of a type which ensures the absence of sparks, arcs and "hot spots" during its normal operation; c) electrical equipment tested specially for Zone 2 (e.g. type "n" protection).
Zone 2	14	Air-locks	As allowed under item 13.
Zone 2	15	Areas of 4 m beyond the cylinder and 4 m beyond the sphere defined in item 7	As allowed under item 13.
Zone 2	16	Areas on open deck extending to the coamings fitted to keep any spills on deck and away from the accommodation and service areas and 3 m beyond these up to a height of 2,4 m above the deck.	As allowed under item 13.
Zone 2	17	Areas on open deck over all cargo tanks (including all ballast tanks within the cargo tank area) where unrestricted natural ventilation is guaranteed and to the full breadth of the unit plus 3 m fore and aft of the forward-most and aft-most cargo tank bulkhead, up to a height of 2,4 m above the deck surrounding open or semi-enclosed spaces of zone 1.	As allowed under item 13.

Hazardous area	Spaces		Electrical equipment
	N°	Description	
Zone 2	18	Spaces forward of the open deck areas to which reference is made in item 10 and item 17, below the level of the main deck, and having an opening on the main deck or at a level less than 0,5m above the main deck, unless: a) the entrances to such spaces do not face the cargo tank area and, together with all other openings to the spaces, including ventilation system inlets and exhausts, are situated at least 5m from the foremost cargo tank and at least 10m measured horizontally from any cargo tank outlet or gas or vapour outlet; and b) the spaces are mechanically ventilated.	As allowed under item 13.
Zone 2	19	An area within 2,4 m of the outer surface of a cargo tank where such surface is exposed to the weather.	As allowed under item 13.

Table 2 : Temperature class and explosion group of certain products -

Product name	Temperature class	Explosion group	Product name	Temperature class	Explosion group
Acetaldehyde	T4	II A	Methane	T1	II A
Ammonia anhydrous	T1	II A	Methyl acetylene propadiene mixture	T4	II A
Butadiene	T2	II B	Methyl bromide	T3	II A
Butane	T2	II A	Methyl chloride	T1	II A
Butane/propane mixture	T2	II A	Monoethylamine	T2	II A
Butylenes	T3	II A	Nitrogen	NF	NF
Chlorine	NF	NF	Pentane (all isomers)	(T2)	(II A)
Diethyl ether	T4	II B	Pentene (all isomers)	(T3)	(II B)
Dimethylamine	T2	II A	Propane	T2	II A
Ethane	T2	II A	Propylene	T2	II B
Ethyl chloride	T2	II A	Propylene oxide	T2	II B
Ethylene	T2	II B	Refrigerant gases	NF	NF
Ethylene oxide	T2	II B	Sulphur dioxide	(T3)	(II B)
Ethylene oxide propylene oxide mixture (max. 30% mass/mass ethylene oxide)	T2	II B	Vinyl chloride	T2	II A
Isoprene	T3	II B	Vinyl ethyl ether	T3	II B
Isopropylamine	T2	II A	Vinylidene chloride	T2	II A

SECTION 11

SAFETY SYSTEM AND FIRE PROTECTION

1 Fire and gas detection

1.1 General

1.1.1 -

Reference is to be made to Ch 3, Sec 13, [6] and Pt C, Ch 4, Sec 2, [6].

2 Emergency shutdown system

2.1 Drawings to be submitted

2.1.1 -

The following documentation is to be sent for approval:

- a) diagrams of emergency shutdown circuits
- b) cause and effect diagrams.

2.2 General requirements and definitions

2.2.1 -

The safest conditions for the systems on board are to be defined.

2.2.2 -

Classification of hazardous areas in ZONES is defined in Pt C, Ch 2, Sec 1, [3.24] of the Rules for the Classification of Ships.

2.2.3 -

All equipment and systems are to be fitted with indicating or monitoring instruments and devices necessary for safe operation.

2.2.4 -

Emergency shutdown systems are to be provided against hazardous events.

Production systems are to be equipped with shutdown systems.

2.2.5 -

Systems that could endanger the safety if they fail or operate outside pre-set conditions are to be provided with automatic shutdown.

The emergency shutdown system is to be automatically activated for example in the event of:

- a) detection of an abnormal operating condition by pressure sensors in the inlet and outlet systems or in the process systems;
- b) detection of combustible gas at a 60% level of the lower explosive limit.

2.2.6 -

An emergency shutdown system (ESD) includes:

- a) manual input devices (push buttons)

- b) interfaces towards other safety systems, e.g.:
 - fire detection system
 - gas detection system
 - alarm and communication systems
 - process shutdown system
 - fire-fighting systems
 - ventilation systems

- c) a central control unit receiving and evaluating signals from the manual input devices and the interfaced systems, and creating output signals to devices that are to be shut down or activated. The ESD central control unit is to include a device providing visual indication of initiated inputs and activated outputs and a local audible alarm

- d) output actuators, e.g. relays, valves and dampers, including status indicators

- e) signal transfer lines between the ESD central control unit and all input devices, interfaced systems and output actuators

- f) power supply.

2.2.7 -

In the context of these requirements under Ch 3, Sec 11, [2], 'circuit' is defined as any signal transfer facility, e.g. electrical, pneumatic, hydraulic, optical or acoustic.

2.2.8 -

A normally energised circuit is a circuit where energy is present, e.g. an electrical current or pneumatic or hydraulic pressure, when the circuit is not activated by the shutdown system.

2.2.9 -

A normally de-energised circuit is a circuit where energy is not present when the circuit is not activated by the shutdown system.

2.3 Basic design principles

2.3.1 -

All shutdowns are to be executed in a predetermined logical manner. The shutdown system is normally to be designed in a hierarchical manner where higher level shutdowns automatically initiate lower level shutdowns.

2.3.2 -

Definition of the shutdown logic and required response times are to be based on consideration of dynamic effects and interactions between systems.

2.3.3 -

Shutdown is not to result in adverse cascade effects, which depends on activation of other protection devices to maintain a plant in a safe condition.

2.3.4 -

The shutdown system is to be designed to ensure that any ongoing operations can be terminated safely when a shutdown is activated.

2.3.5 -

Inter-trips between process systems are to be initiated as a result of any initial event which could cause undesirable cascade effects in other parts of the plant before operator intervention can be realistically expected.

2.3.6 -

Emergency shutdown is to initiate a process shutdown.

2.3.7 -

The shutdown system is to be completely independent of control systems used for normal operation. See also Pt C, Ch 3, Sec 2, [1.1.4] of the Rules for the Classification of Ships.

2.3.8 -

The shutdown system is to be capable of monitoring critical parameters and bring the system to a safe condition if specified conditions are exceeded. See also Pt C, Ch 3, Sec 2, [7] of the Rules for the Classification of Ships.

2.3.9 -

The system is to be designed so that the risk of unintentional shutdown caused by malfunction or inadvertent operation is minimised.

2.3.10 -

The system is to be designed to allow testing without interrupting other systems on board.

2.3.11 -

The central control unit is to be located in a non-hazardous and continuously manned area.

2.3.12 -

The system is to be powered from a monitored Uninterruptible Power Supply (UPS) capable of at least 30 minutes continuous operation on loss of its electrical power supply systems. The UPS is to be powered from both the main and the emergency power system.

2.4 Design and functional requirements

2.4.1 -

Upon failure of the shutdown system, all connected systems are to default to the safest condition Ch 3, Sec 11, [2.1.1] for the unit or installation.

2.4.2 -

Failures to be considered for the shutdown system are to include broken connections and short-circuits on input and output circuits, loss of power supply and, if relevant, loss of communication with other systems.

2.4.3 -

For a shutdown system with only normally energised outputs, all inputs are to be normally energised.

2.4.4 -

For a shutdown system with one or more normally de-energised outputs, all inputs able to activate a normally de-energised output are to be normally de-energised. All normally de-energised input and output circuits are to be monitored for broken connection and short-circuit.

2.4.5 -

Shutdown is not to require unrealistically quick or complex intervention by the operator.

2.4.6 -

Shutdowns on a hierarchical level are automatically to include shutdowns on lower levels.

2.4.7 -

Shutdown is to initiate alarm at the control station. The initiating device and operating status of devices affected by the shutdown action are to be indicated at the control station (e.g. valve position, unit tripped, etc.).

2.4.8 -

Personnel lifts, work platforms and other man-riding equipment are to be designed to enable safe escape after an emergency shutdown, e.g. by controlled descent to an access point on a lower level.

2.4.9 -

Systems which are not permanently attended during operation, and which could endanger safety if they fail, are to be provided with automatic safety control, alert and alarm systems.

2.4.10 -

Plants that are protected by automatic safety systems are to have pre-alarms to alert when operating parameters are exceeding normal levels.

2.4.11 -

The shutdown commands are not to be automatically reset. In case local resets on shut down devices are provided, the indication of the shut down device status is to be given at the main control room.

2.5 Automatic and manual shutdown

2.5.1 -

Shutdowns are normally to be automatically initiated, however solely manually initiated actions may be provided where automatic action could be detrimental to safety.

2.5.2 -

Systems designed for automatic shutdown are also to be designed to enable manual shutdown.

2.5.3 -

Alarms for manual initiation are to be clear and are to be readily identifiable at a permanently manned control station.

2.5.4 -

In all shutdown systems, it is to be possible to manually activate all levels of shutdown at the control station.

2.5.5 -

Other manual shutdown buttons are to be located at strategic locations on the unit or installation.

2.6 Electrical equipment for use in an emergency

2.6.1 -

The following systems are to be operable after abandon unit shutdown:

- a) emergency lighting, for half an hour at:
 - every embarkation station on deck and over sides
 - in all service and accommodation alleyways, stairways and exits, personnel lift cars, and personnel lift trunks
 - in machinery spaces and main generating stations including their control positions
 - in all control stations and machinery control rooms
- b) general alarm
- c) public address
- d) battery supplied radio communication.

2.6.2 -

Electrical equipment left operational after abandon unit shutdown is to be suitable for operation in zone 2 areas with the exceptions given in Ch 3, Sec 11, [2.3.7].

2.6.3 -

Electrical equipment located in non-hazardous areas affected by a gas release, which is left operational after gas detection is to be suitable for zone 2, with the exceptions given in Ch 3, Sec 11, [2.3.7].

2.6.4 -

Safety critical, uncertified electrical equipment may be left operational after ESD or gas detection affecting its area of location, provided that:

- the ventilation to the room where the equipment is located is isolated
- gas detectors are installed in the room where the equipment is located
- facilities for manual shutdown of the equipment are available.

2.7 Emergency shutdown stations

2.7.1 -

Emergency shutdown stations are to be provided for manual activation of the Process Emergency Shutdown system for shutdown of all pumping and process systems.

These manual activation stations are to be protected against accidental activation and are to be conveniently located at the primary evacuation points (i.e., boat landing, helicopter deck, etc.) and the emergency control stations.

For guidance, the following additional locations may be considered appropriate for emergency shutdown stations:

- a) Exit stairway at each deck level
- b) Main exits of living quarters
- c) Main exits of production (process) facility deck.

3 Fire protection, detection and extinction

3.1 General

3.1.1 -

The requirements of this item Ch 3, Sec 11, [3] are not applicable for the purpose of classification, except where the Society carries out surveys relevant to fire protection statutory requirements on behalf of the flag Administration. In such cases, fire protection statutory requirements are considered a matter of class and therefore compliance with these requirements is also verified by the Society for classification purposes.

3.1.2 -

The following requirements apply in addition to those contained in this item Ch 3, Sec 11, [3]:

- a) Chapter 11 of the IGC Code; and
- b) Pt C, Ch 4, Sec 2, [1.2], [1.3], [1.4], [1.5], [3.2.1] b), [4.4], [5.1.1] a), [5.1.3] a) and b), [5.3], [5.5] and [5.7.4];
- c) Flag State requirements, national standards or specific requests by local authorities
- d) Additional requirements on active and passive fire protection stemming from Risk Analysis (Pt C, Ch 7), in particular from Fire and Explosion analysis, which is to define heat loads and smoke effects, the choice of the activation (automatic or manual) and of the extinguishing agent (water, water mist, dry powder or foam or a combination thereof). Particular emphasis is to be put on the locations where personnel can be present in normal and emergency conditions (accommodation, escape routes, temporary refuges, LSA stations etc.).

3.2 Water spray system

3.2.1 -

IGC CODE REFERENCE : Ch 11, 11.3

a) Areas covered

The following areas are also to be covered by the system:

- loading/transfer arm areas where fitted;
- turret areas; and
- process facilities, equipment and vessels,
- bow and stern loading/transfer areas where fitted.

b) Automatic intervention

The need for automatic intervention of the system, or a section of the same, is evaluated by the Society on case-by-case basis. Manual activation of the system is to be provided.

c) Water availability

The capacity of the water pumps is to be adequate to the worst fire scenario likely to be encountered.

The scenario is to be evaluated subject to case-by-case considerations taking account of the actual layout of the protected areas.

Where suitable fire-resistant divisions or adequate distances are arranged between sections, consideration

may be given to decreasing the required amount of water.

3.2.2 Process facility -

A fixed water spray system is to be installed for the process equipment. The intent of the water spray system is to keep the process equipment cool and reduce the risk of escalation of a fire. Water spray systems are to be capable of being actuated both automatically by a fire detection system and manually.

3.3 Dry chemical powder fire-extinguishing system

3.3.1 -

If dry powder is to be used as an extinguishing medium then it is to comply with IGC CODE REFERENCE: Ch 11, 11.4 and the following.

Dry chemical powder fire-extinguishing systems have proven to be suitable for the containment and extinguishing of LPG and LNG pool fires. They have been recommended for use on LNG and LPG carriers. Therefore, with the production of both these type of liquids aboard an FLNG unit, use of such extinguishing medium should also be considered.

3.4 Cargo compressor, equipment and pump rooms

3.4.1 -

Cargo compressor, equipment and pump rooms are to comply with IGC CODE REFERENCE: Ch 11, 11.5 and following.

An FLNG unit may have a number of cargo/process equipment rooms and the risk of fire and/or vapour leakage within these rooms is to be considered. Each space considered a fire risk, such as the process equipment room, cargo deck area, spaces containing gas processing equipment such as compressors, heaters, etc. and machinery spaces containing any oil fired unit or internal combustion machinery are to be fitted with an approved gas detection, fire detection and fire-extinguishing system.

3.5 Gas detection system

3.5.1 -

A fixed gas detection system is to be provided for the following areas:

- hazardous areas, except in Zone 0 and areas mechanically ventilated;
- ventilation outlets from hazardous areas mechanically ventilated;
- intakes for ventilation air, including those for accommodation spaces, service spaces and control stations.

Where the atmosphere in double hull spaces cannot be reliably measured using flexible gas sampling hoses, such spaces shall be fitted with permanent gas sampling lines.

The configuration of gas sampling lines shall be adapted to the design of such spaces.

3.5.2 -

The gas detection system is to indicate both by audible and visible alarm in the control centre the presence of an accumulation of gas corresponding to 25% and 60% of LEL.

3.5.3 -

In cases where concentration of H₂S is expected, equipment suitable for measuring H₂S is to be installed. Visual and audible alarms are to be activated in the main control stations at 10 ppm H₂S.

3.5.4 -

In cargo pump rooms, sampling points or detector heads shall be located in suitable positions in order that potentially dangerous leakage is readily detected. Suitable positions may be the exhaust ventilation duct and lower parts of the pump room above the floor plates.

When the gas concentration reaches a pre-set level, which shall not be higher than 10% LFL, a continuous audible and visual alarm signal shall be automatically initiated in the pump room and in continuously manned stations to alert personnel to the potential hazard.

Sequential sampling is acceptable as long as it is dedicated for the pump room only, including exhaust ducts, and the sampling time is reasonably short.

4 Inert gas system

4.1 Application

4.1.1 -

If a fixed inert gas system is to be fitted, it is to be designed, constructed and tested in accordance with the requirements of Chapter 15 of the Fire Safety System Code, except that, in lieu of the above, the Society, after having given consideration to the unit's arrangement and equipment, may accept other fixed installations if they afford protection equivalent to the above.

The requirements for alternative installations are given in [4.3] below.

4.1.2 -

Units required to be fitted with inert gas systems are to comply with the following provisions:

- double hull spaces are to be fitted with suitable connections for the supply of inert gas
- where hull spaces are connected to a permanently fitted inert gas distribution system, means are to be provided to prevent hydrocarbon gases from the cargo tanks entering the double hull space through the system, and
- where such spaces are not permanently connected to an inert gas distribution system, appropriate means are to be provided to allow connection to the inert gas main.

4.2 General requirements for inert gas systems

4.2.1 -

The inert gas system is to be capable of inerting, purging and gas-freeing empty cargo tanks and maintaining the atmosphere in cargo tanks with the required oxygen content.

4.2.2 -

Units fitted with a fixed inert gas system are to be provided with a closed ullage system.

4.3 Requirements for equivalent systems**4.3.1 -**

When an installation equivalent to a fixed inert gas system is installed, it is to be:

- capable of preventing dangerous accumulations of explosive mixtures in intact cargo tanks during normal service throughout the ballast voyage and necessary in-tank operations, and
- so designed as to minimise the risk of ignition from the generation of static electricity by the system itself.

5 Escape routes, lifesaving and safety equipment**5.1 General****5.1.1 -**

The design of the unit is to include adequate and effective facilities for safe and controlled emergency response during defined accidental events. This includes:

- provision of temporary refuge for all of the personnel onboard, for the time required for incident assessment and controlled evacuation, which includes the protection from heat and toxic substances, the availability of

emergency lighting and ventilation and the means of control, monitoring and communication (ESD, alarms, etc.)

- routes which allow personnel to escape from the immediate effects of a hazardous event to a place of temporary refuge, allowing easy access between deck levels and easy egress to the means of evacuation and escape
- rescue of injured personnel
- safe evacuation of the unit.

The general requirements are given in SOLAS 74 as amended, Reg. II-2/13 for means of escape, and in SOLAS 74 as amended, Reg. III for life-saving appliances and arrangements. They are to be viewed as minimum provisions, and should be supplemented where appropriate.

In particular the following requirements apply:

- a) Pt C, Ch 4, Sec 2 [4 - Means of Escape]
- b) Where necessary, protection against spray of cryogenic material should be provided.
- c) The worst case flaring scenario is to be used in determining radiation levels which might impair escape route availability.

Additional requirements may stem from:

- Flag State requirements, national standards or specific requests by local authorities
- Results of Risk Analysis (Pt C, Ch 7).

SECTION 12

MECHANICAL VENTILATION IN THE CARGO AREA

1 General

1.1 Application

1.1.1 -

The requirements set out in Pt C, Ch 4, [3.5.1] d), [3.5.2] and [3.6] are to be applied, as pertinent, in addition to those contained in this Section.

2 Spaces required to be entered during normal cargo handling operations

2.1 Location of discharges from dangerous spaces

2.1.1 Ventilation duct arrangement -

IGC CODE REFERENCE : Ch 12, 12.1.6

- a) Ventilation ducts are to be arranged at a suitable height from the weather deck. This height is not to be less than 2,4 m for intake ducts.
- b) Ventilation ducts are to be fitted with metallic fire dampers provided with "open" and "closed" signs. These dampers are to be arranged in the open, in a readily accessible position.
- c) Gas-dangerous spaces for the purpose of 1.1.1 a) are those mentioned in paragraph 12.1.5 of the IGC Code. For other spaces which are gas-dangerous only due to their position, some relaxation may be granted.

2.2 Recirculation prevention

2.2.1 -

IGC CODE REFERENCE : Ch 12, 12.1.7

- a) Exhaust ducts from gas-dangerous spaces are to be arranged at a distance in the horizontal direction of at least 10 m from ventilation outlets of gas-safe spaces. Shorter distances may be accepted for ventilation outlets from safe spaces protected by air-locks.
- b) Intakes of gas-dangerous spaces are to be arranged at a distance in the horizontal direction of at least 3 m from ventilation intakes and outlets and openings of accommodation spaces, control stations and other gas-safe spaces.
- c) Exhaust and intake ducts for the same gas-dangerous space, or for the same space rendered safe by an air-lock, are to be arranged at a distance from each other in the horizontal direction of not less than 3 m.

3 Spaces not normally entered

3.1 General requirements

3.1.1 Minimum number of air changes - IGC CODE REFERENCE : Ch 12, 12.2

Both fixed and portable systems are to guarantee the efficient ventilation of such spaces in relation to the relative density, in respect of the air, and to the toxicity of the gases transported. Such ventilation system is to be capable of effecting not less than 8 air changes per hour. The type of portable fans and their connection to the spaces served are to be approved by the Society. In no case are portable electrical fans acceptable.

SECTION 13

INSTRUMENTATION (GAUGING, GAS DETECTION)

1 General

1.1

1.1.1 -

The control and instrumentation systems are to provide an effective means for monitoring and controlling pressures, temperatures, flow rates, liquid levels and other process variables for the safe and continuous operation of the facilities. Where control over the electrical power generation and distribution is required for the operation of the facilities then the control system is also to be arranged to cover this. Control and instrumentation systems for process, process support, utility and electrical systems are to be suitable for the intended application. All control and safety shutdown systems are to be designed for safe operation of the equipment during start-up, shutdown and normal operational conditions.

1.2 Cargo tank instrumentation

1.2.1 -

The instrumentation is to be of a type approved by the Society.

1.3 Detection of leak through secondary barrier

1.3.1 -

IGC CODE REFERENCE : Ch. 13, 13.1.2

Upon special approval, appropriate temperature indicating devices may be accepted by the Society instead of gas detecting devices when the cargo temperature is not lower than -55°C .

1.4 Indicator location

1.4.1 Monitoring list -

IGC CODE REFERENCE : Ch. 13, 13.1.3

A "cargo control room" as dealt with in [3.4.1] of the IGC Code is to be provided.

- a) The following information and alarms relevant to the containment, handling and process systems are to be transferred to the "cargo control room":
 - 1) the indication signalling the presence of water and/or liquid cargo in holds or interbarrier spaces
 - 2) the alarm signalling the presence of liquid cargo in the vent main as per 5.2.1.7 of the IGC Code
 - 3) the indication of the hull temperature and the hull structure low temperature alarm required in 13.5.2 of the IGC Code
 - 4) the alarm signalling the automatic shutdown of electrically driven submerged pumps required in 10.2.2 of the IGC Code

- 5) the indication of the cargo level and the cargo tank high level alarm required in 13.3.1 of the IGC Code
 - 6) the indication of the vapour space pressure and the vapour space pressure gauges of each cargo tank and associated high and low pressure alarms required in 13.4.1 of the IGC Code
 - 7) the gas detection equipment alarm required in 13.6.4 of the IGC Code
 - 8) the indication of the status of all gas compressors with regard to pressures and temperatures
 - 9) the indication of the status of all vaporisers and heaters with regard to all pressures and temperatures
 - 10) the indication of the status of the regasification plant with regard to all pressures and temperatures
- b) The high level and high or low pressure audible and visual alarms for cargo tanks as per 13.3.1 and 13.4.1 of the IGC Code and the alarm signalling the presence of liquid in the vent main are to be located in such a position as to be clearly heard and identifiable by the personnel in charge of loading operation control.

2 Level indicators for cargo tanks

2.1 General

2.1.1 -

IGC CODE REFERENCE : Ch. 13, 13.2.1

- a) In order to assess whether or not one level gauge is acceptable, the wording "any necessary maintenance" is to be interpreted to mean that any part of the level gauge can be overhauled while the cargo tank is in service.
- b) Where level gauges containing cargo are arranged outside the tank they serve, means are to be provided to shut them off automatically in the event of failure.

3 Overflow control

3.1 General

3.1.1 -

The overflow control is to be designed taking into account:

- the operating scenarios of liquefaction and offloading,
- the safe shutdown times of the various process sections,
- the various combinations of degrees of filling of the tanks,
- the loss of vapour flow from the shuttle tanker in case of closure of manifold valves,
- the time required for restarting the whole facility.

Risk Analysis (Pt C, Ch 7) can be used to support the design.

3.2 Overflow alarm and shutdown

3.2.1 Shut-off valve for overflow control - IGC CODE

REFERENCE : Ch. 13, 13.3.1

The sensor for automatic closing of the loading valve for overflow control may be combined with the liquid level indicators required by paragraph 13.2.1 of the IGC Code.

3.2.2 Shut-off valve closing time -

IGC CODE REFERENCE : Ch. 13, 13.3.1

The closing time of the valve referred to in 13.3.1 in seconds (i.e. time from shutdown signal initiation to complete valve closure) is to be not greater than:

$$\frac{3600 \cdot U}{LR}$$

where:

U : Ullage volume at operating signal level (m³)

LR : Maximum loading rate agreed between unit and shore facility (m³/h)

The loading rate is to be adjusted to limit surge pressure on valve closure to an acceptable level.

4 Pressure gauges

4.1 Pressure gauges in cargo tanks

4.1.1 -

IGC CODE REFERENCE : Ch. 13, 13.4.1

The low pressure alarm indicated in paragraph 13.4.1 of the IGC Code is also to be located in the cargo control room.

5 Temperature indicating devices

5.1 General

5.1.1 Temperature recording -

IGC CODE REFERENCE : Ch. 13, 13.5.1

The temperatures are to be continuously recorded at regular intervals. Audible and visual alarms are to be automatically activated when the hull steel temperature approaches the lowest temperature for which the steel has been approved.

6 Gas detection requirements

6.1 General

6.1.1

IGC CODE REFERENCE : Ch. 13, 13.6

The temperatures are to be continuously recorded at regular intervals. Audible and visual alarms are to be automatically

activated when the hull steel temperature approaches the lowest temperature for which the steel has been approved.

6.2 Position of sampling heads

6.2.1 -

The gas sampling heads are to be positioned as per IGC CODE REFERENCE: Ch. 13, 13.6.2 and as prescribe below.

The requirements set out in Part C, Ch 4, Sect 2, [6.2.2] apply.

In all enclosed and semi-enclosed areas where combustible gases might accumulate, gas sensors of an explosion (flame)-proof type are to be installed and operated in accordance with API RP 14C and API RP 14F, as applicable. Consideration is to be given to providing combustible gas sensors near points of a possible leak at process equipment and piping systems located in open areas. Sensors are also to be provided at fresh air inlets to non-classified areas.

6.3 Gas sampling lines

6.3.1 -

IGC CODE REFERENCE : Ch. 13, 13.6.5

The requirements set out in Pt C, Ch 4, Sect 2, [6.2.2] apply.

6.4 Protected spaces

6.4.1 -

IGC CODE REFERENCE : Ch. 13, 13.6.7

In addition to the list in paragraph 13.6.7 of the IGC Code, the gas detection system is also to serve:

- spaces adjacent to pump rooms and compressor rooms,
- areas and spaces where process equipment is located, including gas compressors and turret areas,
- loading and unloading areas,
- intakes for ventilation air,
- air-locks and doorways to enclosed non-hazardous areas,
- intakes for ventilation air,
- ventilation outlets from hazardous areas mechanically ventilated, and
- process areas where hydrocarbons are handled.

6.5 Portable gas detectors

6.5.1 -

IGC CODE REFERENCE : Ch. 13, 13.6.13

For units intended to store toxic and flammable gases, two sets of portable gas detection equipment for toxic gases and two sets for flammable gases are to be provided.

SECTION 14

PROTECTION OF PERSONNEL

1 Personnel protection requirements for individual products

1.1 General

1.1.1 -

IGC CODE REFERENCE: Ch 14 is to be applied throughout the FLNG facility. This is to include protection against any products generated from the liquefaction process and also against any of the hazardous fluids used within the process to treat the feed gas and to stabilise the products. Consideration is also to be given to the possible hazards that may occur due to the use of hydrocarbon based refrigerants.

1.2 Showers and eye wash

1.2.1 -

IGC CODE REFERENCE : Ch 14, 14.4.3

The showers and eye wash are to be fitted with a heating system, or other suitable installation, in order to avoid any ice formation in their piping.

SECTION 15

FILLING LIMITS FOR CARGO TANKS

1 General

1.1

1.1.1 -

Additional or alternative requirements to those indicated in IGC Code Ch 15 can stem from the results of Risk Analysis (Pt C, Ch 7) of the process system in all the envisaged operating conditions.

SECTION 16

USE OF CARGO AS FUEL

1 Gas fuel supply

1.1 Gas fuel supply to machinery spaces under decks

1.1.1 Piping runs -

IGC CODE REFERENCE : Ch. 16, 16.3.1

- a) The main gas line between the gas make-up station and the machinery space is to be as short as possible.
- b) The gas piping is to be installed as high in the space as possible and at the greatest possible distance from the unit's hull.

1.1.2 Segregation of piping -

IGC CODE REFERENCE : Ch. 16, 16.3.1

Gas piping is to be independent of other systems and may only be used for the conveyance of gas. It is to be ensured by its arrangement that it is protected against external damage.

1.1.3 Earth bonding -

IGC CODE REFERENCE : Ch. 16, 16.3.1

Gas piping is to be suitably earthed.

1.1.4 Testing -

IGC CODE REFERENCE : Ch. 16, 16.3.1

Piping, valves and fittings are to be hydrostatically tested, after assembly on board, to 1,5 times the working pressure but to not less than 0,7 MPa. Subsequently, they are to be pneumatically tested to ascertain that all the joints are perfectly tight.

1.2 Valves on the gas fuel supply to machinery spaces under decks

1.2.1 Manual operation -

IGC CODE REFERENCE : Ch. 16, 16.3.6

The three valves indicated in paragraph 16.3.6 of the IGC Code are to be capable of being manually operated.

1.2.2 Automatic operation -

IGC CODE REFERENCE : Ch. 16, 16.3.6

It is to be possible to operate the valves indicated in paragraph 16.3.6 of the IGC Code locally and from each control platform. They are to close automatically under the following service conditions:

- a) whenever the gas pressure varies by more than 10 % or, in the case of supercharged engines, if the differential pressure between gas and charging air is no longer constant
- b) in the event of one of the following fault situations:
 - 1) Gas supply to boiler burners
 - insufficient air supply for complete combustion of the gas
 - extinguishing of the pilot burner for an operating burner, unless the gas supply line to every individual burner is equipped with a quick-closing valve that automatically cuts off the gas
 - low pressure of the gas
 - 2) Gas supply to internal combustion engines
 - failure of supply to pilot fuel injection pump
 - drop of engine speed below the lowest service speed
 - indication by the gas detector in the crankcase vent line that the gas concentration is approaching the lower explosion limit.

2 Gas make-up plant and related storage tanks

2.1 General

2.1.1 Location of equipment for making up gas -

IGC CODE REFERENCE : Ch. 16, 16.4.1

Means for purging of flammable gases before opening are to be provided in the equipment for making up gas.

2.1.2 Equipment located on weather deck - IGC

CODE REFERENCE : Ch. 16, 16.4.1

Where the equipment (heaters, compressors, filters) for making up the gas for its use as fuel and the storage tanks are located on the weather deck, they are to be suitably protected from atmospheric agents and the sea.

2.2 Compressors

2.2.1 Miscellaneous requirements -

IGC CODE REFERENCE : Ch. 16, 16.4.2

- a) The compressors are to be capable of being remotely stopped from an always and easily accessible, non-dangerous position in the open, and also from the engine room.

- b) In addition, the compressors are to be capable of automatically stopping when the suction pressure reaches a certain value depending on the setting pressure of the vacuum relief valves of the cargo tanks.
- c) The automatic shutdown device of the compressors is to have a manual resetting.
- d) Piston-type compressors are to be fitted with relief valves discharging to a position in the open, such as not to give rise to hazards.
- e) Volumetric compressors are to be fitted with pressure/vacuum relief valves discharging into the suction line of the compressor.
- f) The size of the pressure relief valves is to be determined in such a way that, with the delivery valve kept closed, the maximum pressure does not exceed the maximum working pressure by more than 10%.
- g) The compressors are to be fitted with shut-off valves on both the suction and delivery sides.

2.3 Heaters

2.3.1 Additional miscellaneous requirements -

IGC CODE REFERENCE : Ch. 16, 16.4.3

- a) Operation of the heaters is to be automatically regulated depending on the gas temperature at the heater outlet.
- b) Before it is returned to the machinery space, the heating medium (steam or hot water) is to go through a degassing tank located in the cargo area.
- c) Provisions are to be made to detect and signal the presence of gas in the tank. The vent outlet is to be in a safe position and fitted with a flame screen.

3 Special requirements for boilers

3.1 Boiler arrangement

3.1.1 Forced air circulation -

IGC CODE REFERENCE : Ch. 16, 16.5.1

Boilers are to be located as high as possible in boiler spaces and are to be of the membrane wall type or equivalent, so as to create a space with forced air circulation between the membrane wall and the boiler casing.

3.2 Combustion chamber

3.2.1 Gas detectors in the combustion chamber -

IGC CODE REFERENCE : Ch. 16, 16.5.3

The Society may, at its discretion, require gas detectors to be fitted in those combustion chamber areas where gas could accumulate, as well as the provision of suitable air nozzles.

3.3 Burner system

3.3.1 Safety devices -

IGC CODE REFERENCE : Ch. 16, 16.5.4

A mechanical device is to be installed to prevent the gas valve from opening until the air and the fuel oil controls are in the ignition position. A flame screen, which may be incorporated in the burner, is to be fitted on the pipe of each gas burner.

3.3.2 Shut-off -

IGC CODE REFERENCE : Ch. 16, 16.5.4

The gas supply is to be automatically stopped by the shut-off devices specified in paragraph 16.3.6 of the IGC Code.

4 Special requirements for gas fired internal combustion engines and gas fired turbines

4.1 Gas fuel supply to engine

4.1.1 Flame arresters -

IGC CODE REFERENCE : Ch. 16, 16.6

Flame arresters are to be provided at the inlet to the gas supply manifold for the engine.

4.1.2 Manual shut-off -

IGC CODE REFERENCE : Ch. 16, 16.6

Arrangements are to be made so that the gas supply to the engine can be shut off manually from the starting platform or any other control position.

4.1.3 Prevention of fatigue failure -

IGC CODE REFERENCE : Ch. 16, 16.6

The arrangement and installation of the gas piping are to provide the necessary flexibility for the gas supply piping to accommodate the oscillating movements of the engines without risk of fatigue failure.

4.1.4 Protection of gas line connections - IGC CODE

REFERENCE : Ch. 16, 16.6

The connecting of gas line and protection pipes or ducts as per Ch 9, Sec 16, [4.2.1] to the gas fuel injection valves is to provide complete coverage by the protection pipe or ducts.

4.2 Gas fuel supply piping systems

4.2.1 Fuel piping in machinery spaces -

IGC CODE REFERENCE : Ch. 16, 16.6

Gas fuel piping may pass through or extend into machinery spaces or gas-safe spaces other than accommodation spaces, service spaces and control stations provided that they fulfil one of the following conditions:

- a) The system complies with paragraph 16.3.1.1 of the IGC Code, and in addition, with 1, 2 and 3 below:

- 1) The pressure in the space between concentric pipes is monitored continuously. Alarm is to be issued and the automatic valves specified in 16.3.6 of the IGC Code (hereafter referred to as "interlocked gas valves") and the master gas fuel valves specified in 16.3.7 of the IGC Code (hereafter referred to as "master gas valves") are to be closed before the pressure drops to below the inner pipe pressure (however, an interlocked gas valve connected to the vent outlet is to be opened).
 - 2) The construction and strength of the outer pipes are to comply with the requirements of 5.2 of the IGC Code.
 - 3) It is to be so arranged that the inside of the gas fuel supply piping system between the master gas valve and the engine is automatically purged with inert gas when the master gas valve is closed; or
- b) The system complies with paragraph 16.3.1.2 of the IGC Code, and in addition, with 1 to 4 below:
- 1) The materials, construction and strength of protection pipes or ducts and mechanical ventilation systems are to be sufficiently durable against bursting and rapid expansion of high pressure gas in the event of gas pipe burst.
 - 2) The capacity of mechanical ventilating systems is to be determined considering the flow rate of gas fuel and construction and arrangement of protective pipes or ducts, as deemed appropriate by the Society.
 - 3) The air intakes of mechanical ventilating systems are to be provided with non-return devices effective for gas fuel leaks. However, if a gas detector is fitted at the air intakes, this requirement may be dispensed with.
 - 4) The number of flange joints of protective pipes or ducts is to be minimised; or
- c) Alternative arrangements to those given in a) and b) will be specially considered by the Society based upon an equivalent level of safety.

4.2.2 High pressure pipes -

IGC CODE REFERENCE : Ch. 16, 16.6

High pressure gas piping systems are to be checked for sufficient constructive strength by carrying out stress analysis taking into account the stresses due to the weight of the piping system including acceleration load, when significant, internal pressure and loads induced by hog and sag of the unit.

4.2.3 Valves and expansion joints -

IGC CODE REFERENCE : Ch. 16, 16.6

All valves and expansion joints used in high pressure gas fuel supply lines are to be of an approved type.

4.2.4 Pipe joints -

IGC CODE REFERENCE : Ch. 16, 16.6

Joints on the entire length of the gas fuel supply lines are to be butt-welded joints with full penetration and to be fully radiographed, except where specially approved by the Society.

4.2.5 Non-welded pipe joints -

IGC CODE REFERENCE : Ch. 16, 16.6

Pipe joints other than welded joints at the locations specifically approved by the Society are to comply with the appropriate standards recognised by the Society, or with joints whose structural strength has been verified through test analysis as deemed appropriate by the Society.

4.2.6 Post-weld heat treatment -

IGC CODE REFERENCE : Ch. 16, 16.6

For all butt-welded joints of high pressure gas fuel supply lines, post-weld heat treatment is to be performed depending on the kind of material.

4.3 Shut-off of gas fuel supply

4.3.1 Fuel supply shut-off -

IGC CODE REFERENCE : Ch. 16, 16.6

In addition to the causes specified in 16.3.6 of the IGC Code, supply of gas fuel to engines is to be shut off by the interlocked gas valves in the event of the following abnormalities:

- a) abnormality specified in Pt C, Ch 1, App 2 of the Rules for the Classification of Ships
- b) engine stops due to any cause.

4.3.2 Master gas valve shut-off -

IGC CODE REFERENCE : Ch. 16, 16.6

In addition to the causes specified in 16.3.7 of the IGC Code, the master gas valve is to be closed in the event of any of the following:

- a) the oil mist detector or bearing temperature detector specified in Pt C, Ch 1, App 2 of the Rules for the Classification of Ships detects abnormality
- b) any kind of gas fuel leakage is detected
- c) abnormality specified in Pt C, Ch 1, App 2 of the Rules for the Classification of Ships.

4.3.3 Automatic operation -

IGC CODE REFERENCE : Ch. 16, 16.6

The master gas valve is to close automatically upon activation of the interlocked gas valves.

4.4 Emergency stop of dual fuel engines

4.4.1 -

IGC CODE REFERENCE : Ch. 16, 16.6

Dual fuel engines are to be stopped before the gas concentration detected by the gas detectors specified in 16.2.2 of the IGC Code reaches 60% of the lower flammable limit.

4.5 Gas fuel make-up plant and related storage tanks

4.5.1 Equipment construction -

IGC CODE REFERENCE : Ch. 16, 16.6

The construction, control and safety system of high pressure gas compressors, pressure vessels and heat exchangers con-

stituting a gas fuel make-up plant are to be arranged to the satisfaction of the Society.

4.5.2 Fatigue -

IGC CODE REFERENCE : Ch. 16, 16.6

The possibility of fatigue failure of the high pressure gas piping due to vibration is to be considered.

4.5.3 Gas pressure pulsation -

IGC CODE REFERENCE : Ch. 16, 16.6

The possibility of pulsation of gas fuel supply pressure caused by the high pressure gas compressor is to be considered.

4.6 Requirements for gas fired internal combustion engines

4.6.1 General -

IGC CODE REFERENCE : Ch. 16, 16.6

Specific requirements on internal combustion engines supplied by gas are given in Pt C, Ch 1, App 2 of the Rules for the Classification of Ships.

SECTION 17

SPECIAL REQUIREMENTS

1 General

1.1 Liquefaction process

1.1.1 -

The design of the liquefaction process equipment on board an FLNG unit is to be adapted from existing onshore plant designs. Most onshore liquefaction plants are designed to the internationally recognised standards listed below.

- EN 1473:2007 Installation and equipment for liquefied natural gas
- NFPA 59A Standard for the Production Storage and Handling of Liquefied Natural Gas
- API RP 520 Recommended practice for the design and installation of pressure relieving systems
- API RP 521 Guide for pressure relief and depressurising systems
- API RP 550 Manual on installation of refinery instruments and control systems
- API RP 55 Recommended Practices for Oil and Gas Producing and Gas Processing Plant Operations Involving Hydrogen Sulfide
- ANSI and ASME standards.

1.2 Offshore requirements

1.2.1 -

Floating offshore production units are also designed to specific standards, the most widely recognised of which internationally is API (American Petroleum Institute) RP 2FPS: Recommended Practice for Planning, Designing, and Constructing Floating Production Systems. Whilst this standard essentially applies to FPSOs, without a recognised official standard for FLNG units, API RP 2FPS should be considered as the basis for development of FLNG facilities.

- a) Oil Companies International Marine Forum (OCIMF)
 - Hose Standards
 - Ship to Ship Transfer Guide
 - Standards for Oil Tanker Manifolds and Associated Equipment
 - International Safety Guide for Oil Tankers and Terminals
 - Design and Construction specification for marine loading arms
- b) API - American Petroleum Institute
 - API RP 2G Recommended Practice for production Facilities on Offshore Structures
 - API RP 2P Recommended Practice for the Analysis of Spread Mooring Systems for Floating Drilling Units
 - API RP 2FP1 Recommended Practice for Design, Analysis, and Maintenance of Moorings for Floating Production Systems
 - API RP 14G Fire prevention and control
 - API RP 14E Design and installation of offshore production platform piping systems
 - API RP 14F Design and installation of electrical systems for offshore production platforms
 - API RP 520 Recommended practice for the design and installation of pressure relieving systems
 - API 620 Design and Construction of Large, Welded, Low-Pressure Storage Tanks
 - API SPEC-2P Specification For Mooring Chain
 - API RP 2FPS Recommended Practice for Planning, Designing, and Constructing Floating Production Systems
- c) EN 1473:2009 Installation and equipment for liquefied natural gas - Design and testing of marine transfer systems.

SECTION 1	GENERAL
SECTION 2	HULL
SECTION 3	STABILITY
SECTION 4	MACHINERY
SECTION 5	ELECTRICAL INSTALLATIONS
SECTION 6	ELECTRIC PROPULSION PLANT
SECTION 7	AUTOMATION
SECTION 8	SAFETY SYSTEMS
SECTION 9	FIRE PROTECTION, DETECTION AND EXTINGUISHMENT
APPENDIX 1	IMPACT LOADS AND VORTEX SHEDDING
APPENDIX 2	FATIGUE ANALYSIS WITH DETERMINATION OF THE CUMULATIVE DAMAGE
APPENDIX 3	AN EXAMPLE OF ALTERNATIVE CRITERIA FOR A RANGE OF POSITIVE STABILITY AFTER DAMAGE OR FLOODING FOR COLUMN-STABILIZED SEMISUBMERSIBLE UNITS
APPENDIX 4	AN EXAMPLE OF ALTERNATIVE CRITERIA INTACT STABILITY CRITERIA FOR TWIN-PONTOON COLUMN-STABILIZED SEMISUBMERSIBLE UNITS

SECTION 1

GENERAL

1 General

1.1 Application

1.1.1 (1/7/2015)

Units complying with the requirements of this Chapter are eligible for the assignment of the service notation **FPU**, as defined in Pt A, Ch 1, Sec 2, [4.5.1].

1.1.2 (1/7/2015)

Units dealt with in this Chapter are to comply with the requirements stipulated in Part A, Part B, Part C and Part D, as applicable and with the requirements of this Chapter, which are specific to floating units designed and equipped to receive and process well gaseous hydrocarbons.

Some requirements of this Chapter apply to units having the notation **FPU** in lieu of, and not in addition to, the corresponding requirements of Parts B or C: each requirement for which this circumstance occurs is indicated in this chapter.

1.2 Summary table

1.2.1 (1/7/2015)

Tab 1 indicates, for easy reference, the Sections of this Chapter dealing with requirements applicable to units having the notation **FPU**.

Table 1 (1/7/2015)

Main subject	Reference
Hull and stability	Sec 2 and Sec 3
Machinery	Sec 4
Electrical installation	Sec 5
Electrical propulsion plant	Sec 6
Automation	Sec 7
Safety systems	Sec 8
Fire protection, detection and extinction	Sec 9

1.3 Definition

1.3.1 Surface unit (1/7/2015)

A surface unit is a unit with a unit or barge-type displacement hull of single or multiple hull construction intended for operation in the floating condition.

In particular, surface type production units include:

a) Ship type production units

Ship type production units are seagoing ship-shaped units having a displacement type hull or hulls, of the single, catamaran or trimaran types, which have been designed or converted for receiving and processing well gaseous hydrocarbons in the floating condition.

b) Barge type production units

Barge type production units are seagoing units having a displacement type hull or hulls, which have been designed or converted for receiving and processing well gaseous hydrocarbons in the floating condition. Such types of units are not provided with propulsion machinery.

1.3.2 Column-stabilized unit (1/7/2015)

A column-stabilized unit is a displacement unit with the main deck connected to the underwater hull or footings by columns or caissons.

Such columns or caissons are of suitable scantlings and widely spaced such as to provide, together with the underwater hull or hulls, the necessary buoyancy and stability for all modes of operation afloat or the raising or lowering of the unit, as the case may be.

Bracing members of tubular or structural sections may be used to connect the columns, lower hulls or footings and to support the upper structure.

1.3.3 Other types of production units (1/7/2015)

Other types of production units are units which are designed as floating production units and which do not fall into the above-mentioned categories; these units are to be considered on a case by case basis.

1.3.4 Self-propelled unit (1/7/2015)

A self-propelled unit is a unit which is designed for unassisted passage. All other units are considered as non-self-propelled.

1.3.5 Modes of operation (1/7/2015)

Mode of operation means a condition or manner in which a unit may operate or function while on location or in transit. The modes of operation of a unit subject to approval are to include at least the following:

a) Operating conditions

Conditions wherein a unit is on location for the purpose of receiving and processing well gaseous hydrocarbons, or similar operations, and combined environmental and operational loadings are within the appropriate design limits established for such operations.

b) Severe storm conditions

Conditions wherein a unit may be subjected to the most severe environmental loading for which the unit is designed.

c) Transit conditions

Conditions wherein a unit is moving from one geographical location to another.

1.3.6 Freeboard (1/7/2015)

Freeboard is the distance measured vertically downwards amidships from the upper edge of the deck line to the upper edge of the related load line.

1.3.7 Rule length (1/7/2015)

The Rules length L is:

- for ship type units, the distance, in m, on the summer load waterline from the foreside of the stem to the after-side of the rudder post or, if there is no rudder post, to the centre of the rudder stock. The length L is to be not less than 96 per cent and need not be greater than 97 per cent of the length on the summer load waterline. In the case of units with unusual stem or stern arrangements, the determination of the length L will be subject to special consideration;
- for barge type units, the distance, in m, measured on the centreline between the inside surfaces of the stem and stern structures on a waterline at 85 per cent of the depth D, excluding structural protrusions such as anchor rocks etc.;
- for other types of units, the distance, in m, measured from the fore end and the after end projected, if necessary, to the centreline of the unit;
- in the case of units without centreline, the determination of the length will be subject to special consideration.

1.3.8 Moulded breadth (1/7/2015)

The moulded breadth is:

- for ship and barge type units, the greatest horizontal distance, in m, between the inside of the outer shell, measured perpendicularly to the centreline of the unit;
- for other types of units, the greatest overall transverse dimension, in m, measured perpendicularly to the centreline of the unit, excluding structural protrusions such as anchor rocks etc.;
- in the case of units without centreline, the determination of the breadth will be subject to special consideration.

1.3.9 Depth D (1/7/2015)

The Depth D is:

- for ship and barge type units, the vertical distance, in m, measured from the moulded base line to the moulded line of the weather deck at the middle of the length L;
- for other types of units, the vertical distance, in m, measured from the moulded base line to the moulded line of the uppermost continuous deck;

1.3.10 Moulded draught (1/7/2015)

The moulded draught T is the vertical distance, in m, measured from the moulded base line to the assigned load line which is determined according to load line regulations or on the basis of structural or stability considerations. Certain components of a unit's structure, machinery or equipment may extend below the moulded base line.

1.3.11 Moulded base line (1/7/2015)

The moulded base line is a horizontal line extending through the upper surface of the bottom shell plating of the hull or of the lowest hull or of the caisson of the unit.

1.3.12 Water depth (1/7/2015)

The water depth is the vertical distance, in m, from the seabed to the maximum water level, taking into account the effects of the astronomical, barometric and wind tide.

1.3.13 Light weight (1/7/2015)

The light weight is the weight of the complete unit with all its permanently installed machinery and systems, relevant equipment and outfits, including permanent ballast, spare parts normally retained on board, and liquids in machinery and systems at their normal working levels, but does not include liquids not necessary for the operation of machinery and systems, fuel in storage or reserve supply tanks, items of consumable or variable loads, persons on board and their effects.

1.3.14 Weathertight (1/7/2015)

Weathertight means that in any sea conditions water will not penetrate into the unit.

1.3.15 Watertight (1/7/2015)

Watertight means the capability of preventing the passage of water through the structure in any direction under a head of water for which the surrounding structure is designed.

1.3.16 Downflooding (1/7/2015)

Downflooding means any flooding of the interior of any part of the buoyant structure of a unit through openings which cannot be closed watertight or weathertight, as appropriate, in order to meet the intact or damage stability criteria, or which are required for operational reasons to be left open..

1.3.17 Normal operational and habitable conditions (1/7/2015)

Normal operational and habitable conditions means conditions under which the unit as a whole, its machinery, services, means and aids ensuring safe navigation when under way, safety when in the industrial mode, fire and flooding safety, internal and external communications and signals, means of escape and winches for rescue boats, as well as the means of ensuring sufficiently comfortable conditions of habitability, are in working order and functioning normally.

Note 1: Sufficiently comfortable conditions of habitability include at least adequate services for cooking, heating, air-conditioning, mechanical ventilation and fresh and sanitary water.

1.3.18 Gas-tight door (1/7/2015)

A gas-tight door is a solid, close-fitting door designed to resist the passage of gas under normal atmospheric conditions..

1.3.19 Main steering gear (1/7/2015)

The main steering gear is the machinery, the steering gear power units, if any, and ancillary equipment and the means of applying torque to the rudder stock, e.g. tiller or quadrant, necessary for effecting movement of the rudder for the purpose of steering the unit under normal service conditions.

1.3.20 Auxiliary steering gear (1/7/2015)

The auxiliary steering gear is the equipment which is provided for effecting movement of the rudder for the purpose of steering the unit in the event of failure of the main steering gear.

1.3.21 Steering gear power unit (1/7/2015)

The steering gear power unit means:

- a) in the case of electric steering gear, an electric motor and its associated electrical equipment;
- b) in the case of electrohydraulic steering gear, an electric motor and its associated electrical equipment and connected pump;
- c) in the case of other hydraulic gear, a driving engine and connected pump.

1.3.22 Maximum ahead service speed (1/7/2015)

The maximum ahead service speed is the greatest speed which the unit is designed to maintain in service at sea at its deepest seagoing draught.

1.3.23 Maximum astern speed (1/7/2015)

The maximum astern speed is the speed which it is estimated the unit can attain at the designed maximum astern power at its deepest seagoing draught.

SECTION 2

HULL

1 General analysis and design principles

1.1 Methods of analysis and calculation

1.1.1 Foreword (1/7/2015)

The determination of forces, moments, stresses and deflections as well as the definition of corresponding allowable values is to be based upon accepted principles of statics, dynamics and strength of materials and are to be in accordance with the requirements given in this Chapter.

The structural responses due to dynamic loadings are to be determined either by deterministic method or by stochastic method.

1.1.2 Deterministic dynamic analysis (1/7/2015)

This analysis may be performed either by the calculation of the motion of the unit due to the exciting forces given by the design wave or by a quasi-static analysis consisting of a calculation of the hydrodynamic forces acting on the unit assumed as steady and of the addition of inertia forces suitable, together with other acting loads, to achieve the static balance.

1.1.3 Stochastic dynamic analysis (1/7/2015)

This method consists of the calculation of the response function of the unit on regular waves, of the standard deviations on steady random waves (short term responses) and of the long term distribution of motions and stresses of the unit.

1.2 Design

1.2.1 General (1/7/2015)

The units are to be designed and constructed in order to minimize their sensitivity to the environmental actions and to loads during operation, in order to facilitate their construction and surveying.

Structural connections and nodes are to be designed to avoid, as far as practicable, complex structures and stress concentrations.

Units intended for operations in extreme cold areas are to be so arranged that water and ice cannot be trapped in structures or machinery.

In addition, means are to be provided to prevent fresh water, water ballast and intermediate tank fire-fighting water from freezing.

Structures which may be subjected to forces from alongside supply vessels or other floating units are to be locally strengthened and fitted with adequate fenders or sponsons.

The above is not necessary when special berthing and mooring arrangements preventing the structures from being subjected to forces from alongside supply vessels or other floating units are provided.

1.2.2 Scantlings (1/7/2015)

Scantlings of the major structural elements of the unit are to be determined in accordance with the provisions of these Rules.

a) Scantlings of structural elements which are subject to local loads only, and which are not considered to be effective components of the primary structural frame of the unit, shall comply with the applicable requirements of the Rules.

b) Where the unit is fitted with an adequate corrosion protection system, the scantlings may be determined on the basis of the provisions of [4] and taking account of allowable stresses given in [5]; in this case no corrosion allowance is required.

Surface type units are also to comply with the requirements in [6].

1.2.3 Equipment for mooring and anchoring (1/7/2015)

The transit condition is to be referred to for the evaluation of the relevant equipment for mooring and anchoring; the equipment required will be evaluated on a case by case basis.

2 Environmental conditions

2.1 General

2.1.1 (1/7/2015)

In order to design a unit, all environmental phenomena which may produce loads acting on the structures are to be considered.

The environmental phenomena are to be considered both in the structural and in the stability analysis of the unit in all its anticipated conditions.

In order to design the unit, the environmental conditions are to be described in conjunction with the following types of reference conditions defined in Sec 1, [1.3]:

- operating and transit conditions which the operating environmental conditions are associated with;
- severe storm condition which the extreme environmental conditions are associated with.

2.2 Acceptability of the parameters defining the design environmental conditions

2.2.1 (1/7/2015)

The parameters defining the design environmental conditions for which the unit is to be approved are to be based, where possible, upon significant statistical information relevant to the geographical operating and transit areas anticipated for the unit, obtained from statistics covering a sufficiently long period of time and supplied by recognized meteorologic-oceanographic institutes.

When the above-mentioned environmental parameters are based upon extrapolated data or upon forecasting methodologies other than those commonly used, sufficient theoretical information and technical know-how are to be supplied to the Society in order to demonstrate their soundness and their comparability with the official data.

When the available data are discordant, the parameters defining the design environmental conditions are to those which are most conservative.

2.3 Recurrence periods and environmental conditions

2.3.1 (1/7/2015)

In order to design the unit structures, the statistical environmental conditions are to be split into the two following reference conditions:

- operating environmental conditions: the environmental conditions within which the normal industrial activity is performed. The recurrence period of such limiting conditions is to be established by the designer, approved by the Society and recorded in the Operating Manual.
- extreme environmental conditions: environmental conditions defined by a recurrence period as given in [3.1.2].

2.4 Parameters relevant to environmental phenomena

2.4.1 Wind (1/7/2015)

The parameters describing the wind conditions are to be obtained, where possible, on the basis of wind velocity statistics.

For the calculation of the loads due to wind, the statistics relevant to the two following types of wind velocity are to be considered:

- sustained wind velocity;
- gust wind velocity.

The sustained wind velocity is defined as the average wind velocity during a time interval of 1 minute.

The most probable highest sustained wind velocity relevant to an N years recurrence period is referred to as the N years sustained wind velocity".

The gust wind velocity is defined as the average wind velocity during a time interval of 3 seconds.

The most probable highest gust wind velocity relevant to an N years recurrence period is referred to as the N years gust wind velocity".

When data of the wind velocity versus height above the still water level are not available, the following equations may be used.

Sustained wind velocity at a height Z above the still water level:

$$V_{Z,C}(N) = V_{10,C}(N) \cdot (C_H)^{0,5}$$

Gust wind velocity at a height Z above the still water level:

$$V_{Z,R}(N) = V_{10,R}(N) \cdot (Z/10)^{0,085}$$

When $V_{10,R}(N)$ is unknown and only $V_{10,C}(N)$ is known, the following equation may be used:

$$V_{Z,R}(N) = V_{10,C}(N)[0,45 + (Z/10)^{0,085}]$$

where:

- $V_{Z,C}(N)$: N years sustained wind velocity at a height Z, in m/s
- $V_{10,C}(N)$: as $V_{10,C}(N)$ at a height Z = 10 m
- Z : height level referred to still water, in m
- $V_{Z,R}(N)$: N years gust wind velocity at a height Z, in m/s
- $V_{10,C}(N)$: as $V_{Z,R}(N)$, at a height Z = 10 m
- C_H : height coefficient (see Sec 3, [3]).

Formulas for the calculation of wind velocities versus height other than the above are to be previously approved by the Society.

In order to determine the design loads due to the sustained wind velocities, the velocities are generally to be specified by the Interested Parties and are to be not less than the following:

- 36,0 m/s for design loads relevant to the operating environmental conditions;
- 51,5 m/s for design loads relevant to the extreme environmental conditions.

When the unit operating conditions are restricted to sheltered geographical areas, the Society may take into consideration reductions of wind velocity which, for the unit in operating and/or in transit conditions, may in no case be taken less than 25,8 m/s.

2.4.2 Sea waves (1/7/2015)

a) Foreword

The selection criteria of the design wave is to be specified by the Interested Parties and may be defined by means of design deterministic waves having appropriate shapes, dimensions and periods when the deterministic dynamic analysis is used, or by means of power spectral density functions when the probabilistic dynamic analysis is used.

The parameters describing the design waves are to represent realistically the most unfavourable load conditions anticipated for the unit and are to be based upon reliable wave statistics relevant to operating and transit geographical areas anticipated for the unit considered.

Such parameters are to be deemed acceptable by the Society.

In particular, the description parameters of the design waves is to supply the following information:

- The N years wave height defined as the most probable largest wave height the individual wave may reach with a recurrence period of N years for the anticipated geographical areas;
- The definition of the design wave producing the most unfavourable loads for the unit as a whole and/or on a few or all of its main structural compo-

nents. The analysis may show that the most unfavourable loads are induced by a wave other than the N years wave previously defined.

- 3) The evaluations of the probability distribution of the waves the unit will meet during its life. Such information is necessary to analyse the fatigue and its effects on the structural components.
- b) Deterministic description of the waves

When the deterministic method of sea description is used, the design waves are defined by means of the following parameters:

H, T, λ, h

- H : wave height, i.e. the distance measured vertically between the crest and the trough of the wave, in m;
- T : wave period, in s;
- λ : wave length, in m;
- h : as mean sea depth calculated from the still water level, in m.

Where necessary, the finite depth effects are to be taken into consideration.

The analysis of wave induced loads on the unit is to be carried out for a few wave periods in order to ensure a sufficiently accurate determination of the maximum loads.

Normally it is sufficient to investigate the following range of wave periods which may turn out to be significant:

$$0, 8(H/g)^{0,5} \leq T \leq 20$$

where g is the gravity acceleration, in m/s^2 .

In order to define the design wave height, the smaller of the heights defined as follows is to be selected:

- 1) the N years wave height relevant to the geographical operating and transit areas anticipated for the unit;
- 2) the breaking wave height defined according to the wave periods and to the water depths relevant to the geographical operating and transit areas anticipated for the unit.

As guidance, the curves of the breaking wave height H_F versus the above-mentioned parameters are shown in the diagram in Fig 1.

- c) Stochastic description of the waves

When the stochastic method of sea description is used, the waves are analysed taking into account stationary irregular sea states described by the spectral power density functions which are parametrically defined by the significant wave height $H/3$ and by the average apparent wave period T the analytical expressions of the spectral power density functions of the sea states is to reflect the shape and the amplitude of the typical spectra of the significant sea states of the significant sea states of the geographical operating and transit areas anticipated for the unit.

The spectral power density function in the Pierson Moskowitz analytic formulation is generally applied for open deep-water sea areas.

In general, a narrower-banded spectrum, e.g. the Jonswap spectrum, is to be used for shallow water.

According to the dynamic analysis methodology, the long term sea behaviour is mathematically described by means of the occurrence probability of each short term spectrum, i.e. by means of a distribution function of the sea states.

In general, the distribution function is used in biparametrical form ($H_{1/3}, T$), and is obtained, as a rule, from wave statistics relevant to the geographical areas considered

2.4.3 Tides (1/7/2015)

In order to define the design depth, it is necessary to know the values of the sea level increase produced by tides.

The calculation of the depth increase due to tides is necessary for self-elevating units in order to define the crest clearance between the underside of the unit in the elevated position and the crest of the highest wave.

The three following tide components are to be considered to define sea level increase in respect of its mean value:

- astronomical tide;
- barometric tide;
- wind tide.

The astronomical tide is due to the attraction force exerted on the oceans by the moon and the sun.

The barometric tide is due to the low pressure level conditions associated with the local presence of storms.

The values reached by the barometric tides are generally less than those reached by other tide components.

The variation ΔZB , in m, of the water level due to a variation Δp , in N/mm^2 , of the barometric pressure is given by the following equation:

$$\Delta ZB = 102\Delta p$$

The wind tide is due to the tangential action exerted by wind on the water surface which results in an accumulation of water masses against the coasts.

The values of the wind tide are difficult to calculate and may be obtained, as for the values of astronomical tide, from tables and graphs supplied by recognized meteorological-oceanographic institutes.

2.4.4 Currents (1/7/2015)

The current velocity data relevant to the operating areas anticipated for the unit are to be obtained, as far as possible, from reliable statistics.

In order to calculate the design current velocity, all current components which are deemed to be significant are to be taken into account; the main current components are generally the following:

- tide component;
- wind component;
- convection component due to thermal variations.

The design current velocity is given by the vector sum of the individual current components:

$$\vec{V}_{CZ} = \vec{V}_{Cm} + \vec{V}_{Cv} + \vec{V}_{Ct}$$

where:

- V_{CZ} : total current velocity, at a distance Z above the sea bottom, in m/s;
- V_{Cm} : current component velocity, at a distance Z above the sea bottom, due to tide, in m/s;
- V_{Cv} : current component velocity, at a distance Z above the sea bottom, due to wind, in m/s;
- V_{Ct} : current component velocity, at a distance Z above the sea bottom, due to thermal variations, in m/s.

When reliable data relevant to current velocity variations versus the distance from the sea bottom are not available, the following equations for

$$\vec{V}_{Cm}$$

and

$$\vec{V}_{Cv}$$

in m/s, may be used:

$$\vec{V}_{Cm} = \vec{V}_{Ct}(Z/h)^{\frac{1}{2}}$$

$$\vec{V}_{Cv} = \vec{V}_{C2}(Z/h)$$

where:

- V_{C1} : velocity of the still water surface current due to tide, in m/s;
- V_{C2} : velocity of the still water surface current due to wind, in m/s;;
- Z : distance from the sea bottom of the point where the current velocity is to be calculated, in m;;
- h : distance from the sea bottom of the still water surface, in m.

When reliable statistics are not available to calculate the current velocity

$$\vec{V}_{C2}$$

in open sea areas, the following equation may be used:

$$\vec{V}_{C2} = 0,01 \vec{V}_{10,C}(N)$$

where:

- $V_{10,C}(N)$: N years sustained wind velocity, as previously defined, at a height $Z = 10$ m above the still water level, in m/s.

The current velocity due to tide, to be used in conjunction with the design wave height, shall be not less than 0,5 m/s.

2.4.5 Temperature (1/7/2015)

The design temperature is to be defined, according to Pt B, Ch 4, Sec 1, [2.5] of the Rules for the Classification of Ships on the basis of the operating and transit geographical areas anticipated for the unit.

Figure 1 : Breaking wave height ($N_{F,NL}$) (1/7/2015)

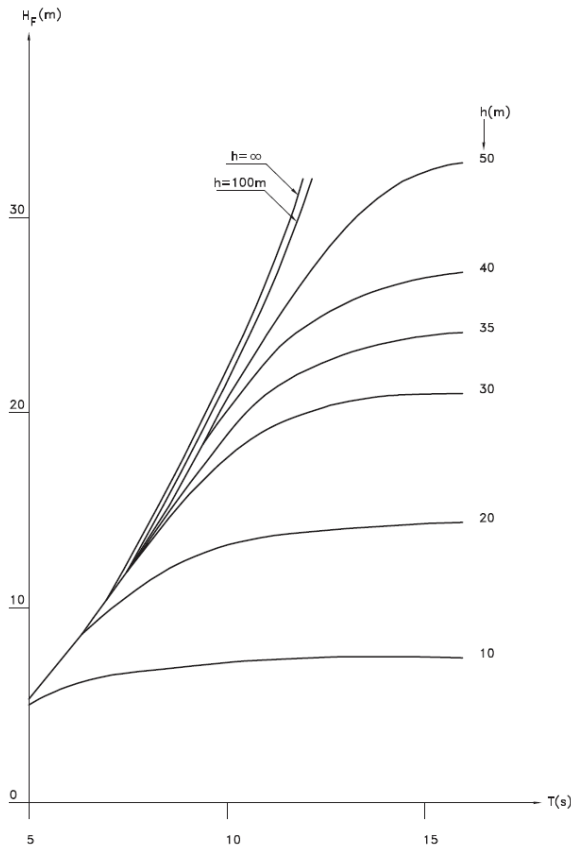

3 Environmental conditions and design loads

3.1 General

3.1.1 (1/7/2015)

The modes of operation for each unit are to be investigated using realistic loading conditions including gravity loadings with relevant environmental loadings.

The following environmental conditions are to be included where applicable:

- a) wind;
- b) wave;
- c) current;
- d) ice;
- e) sea bed conditions;
- f) temperature;
- g) fouling; and
- h) earthquake.

3.1.2 (1/7/2015)

Where possible, the above design environmental conditions are to be based upon significant data with a period of recurrence of at least 50 years for the most severe anticipated environment.

Such recurrence period is to be increased when the Society deems it necessary to adopt more severe environmental conditions.

If a unit is restricted to seasonal operations in order to avoid extremes of wind and wave, such seasonal limitations are also to be specified.

3.1.3 (1/7/2015)

Results from relevant model tests may be used to substantiate or amplify calculations.

3.1.4 (1/7/2015)

Limiting design data for each mode of operation are to be stated in the Operating Manual.

3.1.5 (1/7/2015)

Where applicable, the design loads indicated herein are to be adhered to for all types of floating production units. The owner (designer) will specify the environmental conditions for which the unit is to be approved.

3.2 Gravity loads

3.2.1 (1/7/2015)

These loads include:

- the actual weight of the structure including, where applicable, hull, columns, bracing, superstructures,

platform and any other significant structural element of the unit;

- the weight of equipment and machinery including all working equipment and appliances, relevant to process and any other marine industrial work;
- the weight of all the reserves and stores used during industrial work, such as mud, chemical, water, fuel, etc.;
- the weight of water in pipes and tanks during hydrostatic tests;
- the weight of ballast.

3.3 Functional Loads

3.3.1 (1/7/2015)

The functional loads include all those loads which occur due to industrial operation of the unit under ideal environmental conditions, i.e. without any environmental loads.

With regard to functional loads acting on decks, a loading plan is to be prepared to the satisfaction of the Society showing the maximum design uniform and concentrated deck loadings for each area for each mode of operation.

Such loading plan is to be included in the Operating Manual.

Design functional loads are to be not less than:

- a) crew spaces, accommodation spaces, walkways, etc.): 4,5 kN/m²
- b) work areas: 9,0 kN/m²;
- c) storage areas: 13,0 kN/m²;
- d) helideck: 2 kN/m².

Design loads lower than those specified above may be accepted provided that the structures concerned, considered as subjected to the latter loads, do not bear stresses higher than those which are allowed in the case of combined loads.

3.4 Environmental loads

3.4.1 Foreword (1/7/2015)

All the forces induced on the unit by environmental factors are defined as environmental loads.

The values of the environmental loads may be evaluated either by means of calculations or by means of reliable experimental tests carried out by recognized institutes.

Since environmental factors are of a random nature, their values are to be calculated, in principle, by means of non-deterministic analysis.

The design shall suitably take into account the simultaneous occurrence of different environmental phenomena by superimposing their individual effects.

3.4.2 Wind loading (1/7/2015)

Sustained and gust wind velocities, as relevant, are to be considered when determining wind loading.

Pressures and resultant forces are to be calculated by the method referred to in Sec 3, [3] or by some other method to the satisfaction of the Society.

Alternatively, wind tunnel data obtained from reliable model tests carried out by recognized laboratories for the evaluation of the wind pressures and forces may be submitted to the Society.

Special attention is to be paid to the design of structures affected by dynamic loads.

Any external surface of closed structures which are not effectively shielded shall be analysed to check the effects of the positive and negative pressure; to this end the following equation may be used:

$$p(Z) = \frac{1}{2}\rho V^2(Z)C_p \cdot 10^{-3} \quad (\text{kN/m}^2)$$

where:

C_p : pressure coefficient, the values of which are as follows:

- $\pm 1,0$, for vertical surfaces;
- $-1,0$, for horizontal surfaces.

The meaning of the other parameters is that given above and in Sec 3, [3].

3.4.3 Wave loading (1/7/2015)

a) Description of design wave criteria

Design wave criteria are to be described by design wave energy spectra or deterministic design waves having appropriate shape and size.

Consideration is to be given to waves of lesser height, where due to their period, the effects on structural elements may be greater.

b) Evaluation of design wave forces

The wave forces utilized in the design analysis are to include the effects of immersion, heeling and accelerations due to motion.

Such forces are constituted by:

- 1) inertia forces resulting from accelerations of wave water particles and from accelerations due to unit movements;
- 2) drag forces resulting from the boundary layer effects of the sea flow around wetted structures;
- 3) impact forces due to wave slamming against structural members;
- 4) hydrostatic forces resulting from the variations of the wave profile and from the unit movements.

Theories used for the calculation of wave forces and selection of relevant coefficients are to be to the satisfaction of the Society.

The wave forces may affect a structural member both as a single member and as one of a group of similar members; in the latter case the interaction or group effects are present.

When the equivalent diameter of the single structural members is of the same order of magnitude as the distance between the members themselves, the interaction effects (solidification effect, shielding effect and synchronization effect) are to be considered in the calculation of the hydrodynamic forces.

Such effects are more pronounced, the nearer the members are to each other and to the free surface of the water.

- Inertia forces

Different methods may be used to calculate the inertia forces.

In particular, the Morison method may be used on the assumption that the equivalent diameter of the member considered would not significantly deform the incident wave, i.e. on the assumption that the ratio of the member equivalent diameter to the wave length is very small.

A more suitable theory, e.g. the potential theory, is generally to be used for bodies with equivalent diameter which is not negligible compared to wave length; in general, for such bodies, the inertia forces are preponderant with respect to drag forces, which may therefore be disregarded.

For cylindrical elements, both ends of which are not free (i.e. with the characteristic that only the cylindrical surface is subject to wave action) and having arbitrary cross-sectional shape, the following Morison equation for the inertia force vector $F_{i\tau}$, in kN, is generally accepted:

$$\vec{F}_i = \rho \cdot A \cdot \Delta l \cdot [(1 + C_m) \cdot \vec{u} \wedge \vec{a}_w \wedge \vec{u} - C_m \cdot \vec{u} \wedge \vec{a}_e \wedge \vec{u}] \cdot 10^{-3}$$

where:

- ρ : specific mass of water, in kg/m³;
- A : cross-sectional area of the structural element considered, in m²;
- Δl : length of the axis of the structural element considered, in m;
- C_m : added mass coefficient depending upon the shape of the cylindrical element considered;
- u : unit vector of the cylindrical element axis;
- a_w : water particles acceleration vector due to the waves, in m/s²;
- a_e : structural element acceleration due to the movement of the unit on the waves, in m/s².

For a practically isolated structural element (i.e. with equivalent diameter preponderant with respect to the bracing equivalent diameter), the following Morison equation for the inertia force vector $F_{i\tau}$, in kN, is generally accepted:

$$\vec{F}_i = \rho \cdot V \cdot [(1 + C_m) \cdot \vec{u} \wedge \vec{a}_w \wedge \vec{u} - C_m \cdot \vec{u} \wedge \vec{a}_e \wedge \vec{u}] \cdot 10^{-3}$$

where:

- V : volume of the structural element considered, in m³;

The other symbols are as defined above.

- Drag forces

Different methods may be used to evaluate the drag forces.

In particular the Morison method may be used on the same assumption specified above for inertia forces.

For cylindrical elements, both ends of which are not free (i.e. with the characteristic that only the cylindrical surface is subject to wave action) and having arbitrary cross-sectional shape, the following Morison equation for the drag force vector $F_{D\tau}$, in kN, is generally accepted:

$$\vec{F}_D = \frac{1}{2} \rho \cdot D \cdot \Delta l \cdot C_D \cdot v \cdot \vec{u} \wedge \vec{v} \wedge \vec{u} \cdot 10^{-3}$$

- D : cross-section dimension of the cylindrical element considered normally to the plane defined by the axis of the element and the vector v , in m;
- Δl : length of the structural element, in m;
- C_D : drag coefficient;
- v : modulus of vector v , in m/s;
- v : relative velocity vector of the water particles with respect to the element;
- u : unit vector of the cylindrical element axis.

The vector v results from the following equation:

$$v = \vec{v}_w \cdot \vec{v}_e \cdot \vec{v}_u$$

where:

- v_w : orbital velocity vector of water particles due to waves;
- v_e : velocity vector of the structural element due to the motion of the unit on the waves;
- v_u : advancing velocity vector of the unit.

For a practically isolated structural element (i.e. with equivalent diameter preponderant with respect to the equivalent diameter of the bracings), the drag force may generally be disregarded when compared to the inertia force.

When the drag force is significant, the following Morison equation is generally applied:

$$\vec{F}_D = \frac{1}{2} \rho \cdot A \cdot C_D \cdot v \cdot \vec{u} \wedge \vec{v} \wedge \vec{u} \cdot 10^{-3}$$

where:

- A : cross-sectional area of the structural element considered, in m²;

- Impact forces

Impact forces from waves against the structures shall be determined according to recognized theoretical methods or from results of model tests.

Possible dynamic amplification of such forces shall be carefully considered.

In App 1 a method for calculating such forces is described.

- Wave induced vibrations
Consideration should be given to the possibility of wave induced vibrations.

3.4.4 Current loadings (1/7/2015)

The current induced forces acting on immersed members are drag forces.

The following Morison equations may be considered to calculate the forces due to current on the same assumption specified above for drag forces due to waves:

- for structural cylindrical elements both ends of which are not free, whatever their cross section is:

$$\vec{F}_{DC} = \frac{1}{2} \rho \cdot D \cdot \Delta l \cdot v_c \cdot \vec{u} \wedge \vec{v}_c \wedge \vec{u} \cdot 10^{-3}$$

- for cylindrical structural elements which are practically isolated:

$$\vec{F}_{DC} = \frac{1}{2} \rho \cdot A \cdot C_D \cdot v_c \cdot \vec{u} \wedge \vec{v}_c \wedge \vec{u} \cdot 10^{-3}$$

where:

- F_{DC} : drag force vector due to current, in kN;
 v_c : modulus of vector v_c in m/s;
 v_c : current velocity vector for the location in which the unit rests.

The other symbols are as defined above.

Consideration is to be given to the interaction of current and waves. Where necessary, the effects are to be superimposed by adding the constant current velocity v_c vectorially to the orbital wave particle velocity. The resultant velocity should be used in calculating the structural loading due to current and waves.

3.4.5 Loading due to vortex shedding (1/7/2015)

Consideration is to be given to loading induced in structural members due to vortex shedding.

The von Karman vortices may occur downstream from the cylindrical structural elements, whatever their cross section is, when the flow around them and normally to their axis reaches critical velocities.

In app 1 a method for the determination of hydrodynamic forces induced by vortex shedding is described.

3.4.6 Loading due to ice (1/7/2015)

The following forces due to ice are to be considered, when relevant, for units designed for operations in geographic areas where the design temperature is less than 0°C:

- static forces due to ice accumulation on superstructures and decks;
- impact forces due to ice masses falling on structures;
- impact forces due to the impact of the unit against icebergs;
- forces exerted on the structures by the freezing of sea sprays;
- forces exerted on the wind exposed structures caused by the increase of the areas of wind exposed surfaces due to ice.

For the definition of design temperature, see [2.4.5].

3.5 Additional loads

3.5.1 Foreword (1/7/2015)

All loads that are not covered by the definition of gravity, functional or environmental loads are defined as additional loads.

The main additional loads are the following:

- loads arising from maintaining the unit on station;;
- loads arising from towing operations;
- loads arising from boarding;
- loads arising from building and positioning operations.

3.5.2 Additional loads arising from maintaining the unit on station (1/7/2015)

The additional loads due to systems and equipment fitted to maintain the unit on station are to be considered according to the two following structural aspects:

- loads relevant to the overall strength of the unit structure;
- loads relevant to the local strength of the structure where the maintaining on station forces are transmitted to the unit.

For calculation of the above-mentioned loads, the forces due to waves, wind and current, are to be taken into account in addition to the pretension force of the mooring lines.

For calculation of the above loads, due account is to be taken of all mooring configurations and of all associated environmental conditions indicated in the Operating Manual.

When, for calculation of the overall strength of the unit, the motion of the latter due to waves is evaluated, the horizontal force components of the mooring lines are to be considered taking into account, in the motion equations, the adequate elastic constants of the mooring lines.

Of the six degrees of freedom movements of the unit, the mooring line tensions may only be significantly modified by the following horizontal movements:

- surge
- sway
- yaw

while the variation of the mooring line tensions due to the following movements:

- heave
- roll
- pitch

may be disregarded.

When the quasi-static analysis (see [1.1.2]) is used for the calculation of the overall strength of the unit, the horizontal force components of the mooring lines are to be considered equal and opposite to the forces arising from wind and current.

The loads induced on the structures by the dynamic positioning systems shall be considered when relevant.

3.5.3 Additional loads arising from towing operations (1/7/2015)

The additional loads arising from towing operations are applicable to the unit while it is being towed by tugs; they may be subdivided into the following forces:

- a) static forces applied to the unit-tug connections; these depend on the velocity of the unit transit motions on water (resulting from the unit transit velocity and from the current velocity, both measured with respect to the seabed) and on the wind velocity;
- b) dynamic forces applied to the unit-tug connections; these arise from the unit-tug relative movement caused by the wave action.

3.5.4 Additional loads arising from building and positioning operations (1/7/2015)

These loads applied to the unit structures occur during the construction and positioning operations.

The following stages of such operations may give rise to considerable stresses:

- assembling
- launching
- drydocking
- immersion
- emersion
- raising and lowering of self-elevating units or of any other type of articulated unit, etc.

3.5.5 Additional loads arising from boarding (1/7/2015)

The loads arising from boarding are impulsive and are due to the relative movements of the unit and vessels alongside.

The following equation for the evaluation of the maximum value of the boarding force is given for guidance:

$$F_{abb} = \left(2,5 \frac{H}{gT^2} + 0,05\right)P$$

where:

- F_{abb} : boarding force, in kN;
 H : maximum wave height for which the possibility of boarding is accepted, in m;
 T : period of the above-mentioned wave, in s;
 P : maximum anticipated weight for the vessel whose boarding force is to be evaluated, in kN;
 g : gravity acceleration, in m/s^2 .

When a spectral definition of the sea states is used, H and T are, respectively, the significant wave height and mean apparent period values of the state in which boarding is expected to occur.

4 Structural analysis

4.1

4.1.1 (1/7/2015)

Sufficient loading conditions for all modes of operation are to be analysed to enable the critical design cases for all principal structural components to be evaluated.

This design analysis should be to the satisfaction of the Society.

Calculations for relevant conditions are to be submitted to the Society for consideration.

The analysis is to be performed using an appropriate calculation method and are to be fully documented with references.

The Society may, at its discretion, require the application of design loads other than those mentioned above when this is called for by the particular type, structure or use of the unit.

For each considered loading condition, relevant to the associated operational condition, the following primary stresses shall be determined for comparison with the appropriate allowable stresses given in 5.

- a) stresses due to static loading only, in calm water conditions, where the "static loads" include functional loads and gravity loads acting on the structures, with the unit afloat or resting on the sea-bed, as applicable;
- b) stresses due to combined loading, where the applicable static loads in a) are combined with significant design environmental loads, including acceleration and heeling forces.

4.1.2 (1/7/2015)

The scantlings are to be determined on the basis of criteria which combine, in a rational manner, the individual stress components in each structural element.

Such criteria are to be acceptable to the Society.

The allowable stresses are to be to the satisfaction of the Society.

4.1.3 (1/7/2015)

Local stresses, including stresses caused by circumferential loadings on tubular members, are to be added to primary stresses in evaluating combined stress levels.

4.1.4 (1/7/2015)

For calculation of bending stresses, the effective flange areas are to be determined in accordance with effective width concepts acceptable to the Society.

Elastic deflections are to be taken into account, as appropriate, when determining the effects of eccentricity of axial loading, and the resulting bending moments are to be superimposed on the bending moments calculated for other types of loading.

4.1.5 (1/7/2015)

For calculation of shear stresses in bulkheads, plate girder webs or hull side plating, only the effective shear area of the web are to be considered.

In this regard, the total depth of the girder may be considered as the web depth.

4.1.6 (1/7/2015)

For structural components analysed within the linear elastic field, the equivalent stresses calculated according to von Mises' criterion may not exceed the permissible stresses given in [5].

Criteria other than the von Mises' criterion used in the evaluation of equivalent stresses are to be submitted to the Society for approval.

4.1.7 (1/7/2015)

Members of grillage type structures are to be designed in accordance with recognized calculation methods for such structures.

4.1.8 (1/7/2015)

The buckling strength of structural members is to be evaluated where appropriate.

The buckling analysis of the structures is to be carried out using generally accepted theories.

Buckling analysis criteria other than those commonly used are subject to approval by the Society.

For structures subject to buckling, the effect of the predeformations due to geometrical and construction imperfections shall, if possible, be taken into account for the determination of the critical buckling stresses.

In the case of structural members analysed as beams, the critical buckling stress may be determined as follows:

$$\sigma_{cr} = \left[1 - \frac{1}{2} \left(\frac{\lambda_0}{\lambda} \right)^2 \right] \sigma_s \quad \text{if } \lambda < \lambda_0$$

$$\sigma_{cr} = \frac{1}{2} \left(\frac{\lambda_0}{\lambda} \right)^2 \sigma_s \quad \text{if } \lambda \geq \lambda_0$$

where:

σ_s : yield strength of the material;

$$\lambda = \frac{Kl}{r}$$

$$\lambda_0 = \left(\frac{2\pi^2 E}{\sigma_s} \right)^{0.5}$$

Kl : effective unsupported length;

R : governing (minimum) radius of gyration associated with Kl ;

E : modulus of elasticity of material.

When the beam concerned is made of compound members or is subject to local buckling, the critical buckling stress are to be suitably reduced.

When structural members under compression are subjected to combined stress condition, possible second order effects are to be taken into account.

In particular, in the case of beams subjected to combined compression and bending, the bending stress are to be multiplied by the amplifying coefficient equal to:

$$\frac{1}{1 - \frac{\sigma_c}{\sigma_{cr}}}$$

where σ_c is the stress due to compression only.

Structural members subjected to torsional buckling in loading conditions lower than those which may produce lateral buckling are to be checked for torsional buckling.

Stiffeners are to be analysed in such a way that the stiffened plate has a total buckling load higher than the local buckling load of single panels between the stiffeners.

Unstiffened or ring stiffened cylindrical structures with circular cross section subjected to axial compression, or compression due to bending, or a combination thereof, and having proportions which satisfy the following relationship:

$$\frac{D}{t} < \frac{E}{9\sigma_s}$$

where:

D : cylinder mean diameter;

t : cylinder wall thickness.

need not be checked for local buckling.

Designs based on novel or unconventional methods such as plastic analysis or elastic buckling concepts will be specially considered by the Society.

4.1.9 (1/7/2015)

Where deemed necessary by the Society, a fatigue analysis based on intended operating areas or environments is to be provided.

The fatigue analysis of the structural elements is to be based upon a period of time not less than the anticipated unit life, normally not less than 20 years.

The detailed fatigue analysis is generally carried out on particularly critical structures, e.g. on joints.

The fatigue analysis criteria used in the unit design is subject to acceptance by the Society.

When the fatigue analysis is performed with the cumulative damage method, as mentioned in App 2, the allowable limits of the cumulative damage will be subject to special consideration by the Society.

The equivalent stresses used in the fatigue analysis are to take into account stress concentration and the effect that cyclical loads may have on corrosion.

4.1.10 (1/7/2015)

The effect of notches, local stress concentrations and other stress raisers should be allowed for in the design of primary structural elements.

4.1.11 (1/7/2015)

Where possible, structural joints are to not designed so that they do not transmit primary tensile stresses through the thickness of plates integral with the joint.

Where such joints are unavoidable, the plate material properties and inspection procedures selected to prevent lamellar tearing are to be to the satisfaction of the Society.

4.1.12 (1/7/2015)

In addition to the above, the unit structures are to be investigated with respect to the following effects, when appropriate:

- brittle fracture;
- excessive deformation;
- loss of water-tightness;
- excessive vibrations.

The most unfavourable stresses for a unit may be associated with conditions less severe than the extreme design environmental conditions specified by the Designer.

In this case the Society may require such additional environmental conditions to be considered taking account of one or both of the following precautions:

- a) appropriate reduction of the allowable stresses associated with the case of combined loads;
- b) careful investigation of the fatigue behaviour of the structures concerned.

5 Safety factors and permissible stresses

5.1

5.1.1 (1/7/2015)

The safety factors indicated in Tab 1 are to be considered in the structural analysis of all the members of the platform in relation to the possible types of collapse.

Where, for a structural member under compression, the critical buckling load P_{cr} is higher than the proportional load P_p , the safety factor for buckling may be assumed equal to:

$$\frac{1,5}{1 - 0,13(P_p/P_{cr})^{0,5}}$$

P_p being the extreme load between the elastic and the inelastic buckling [4.1.8] apply, is to be assumed to be equal to half the yield stress.

Table 1 (1/7/2015)

Type of collapse	Safety factor
yielding	1,5
failure	1,725
buckling	1,725

5.1.2 (1/7/2015)

In the case of structural members analysed as beams, the stresses calculated for the single types of stress are not to exceed the following values:

- tensile: $0,6 \sigma_s$
- shear: $0,6 \sigma_s$
- bending: $0,6 \sigma_s$
- compression:

$$\sigma_a = 0,6 \left(1 - 0,13 \frac{\lambda}{\lambda_0} \right)^2 \sigma_{cr} \quad \text{if } \lambda < \lambda_0$$

$$\sigma_a = 0,522 \cdot \sigma_{cr} \quad \text{if } \lambda \leq \lambda_0$$

- tensile and bending:

$$\frac{\sigma_t}{0,6 \cdot \sigma_s} + \frac{\sigma_f}{0,6 \cdot \sigma_s} \leq 1,0$$

- compression and bending:

$$\frac{\sigma_c}{\sigma_a} + \frac{\sigma_f}{0,6 \cdot \sigma_s} \leq 1,0$$

where:

- σ_t : tensile stress;
- σ_c : compressive stress;
- σ_f : maximum stress due to bending, which shall be multiplied, in the case of members subject to compression and bending, by the amplifying coefficient given in [4.1.8];

σ_{cr} : critical buckling stress (see [4.1.8]).

Where the beam concerned is subject to local buckling, the permissible bending stresses shall be suitably reduced.

5.1.3 (1/7/2015)

Where they are referred to combined stresses (see [4.1.1]), the values of the safety factors given in [5.1.1] may be reduced by 1/4 and the permissible stresses given in [5.1.2] may be increased by 1/3.

Note 1: The allowable stresses as stated above are intended to reflect uncertainties in environmental data, determination of loadings from the data and calculation of stresses.

It is understood that the adoption of separate load factors or safety factors for the above influences may be allowed, and that allowance can be given for improvements in environmental condition forecasting, load estimation or structural analysis, as the technology or expertise in any one of these areas improves.

6 Special design principles applied to surface units

6.1 Hull

6.1.1 (1/7/2015)

Consideration should be given by means of suitable compensation to the scantlings necessary to maintain strength in way of large hatches.

6.1.2 (1/7/2015)

The structure in way of heavy concentrated loads is to be suitably reinforced.

6.1.3 (1/7/2015)

The structure in way of components for the position mooring system such as fairleads and winches is to be de-signed to withstand the stresses imposed when a mooring line is loaded to its breaking strength.

7 Special design principles applied to column stabilized units

7.1 General

7.1.1 (1/7/2015)

For units of this type, the highest stresses may be associated with less severe environmental conditions than the maxim specified by the designer or by the owner.

Where considered necessary by the Society, account is to be taken of the consequent increased possibility of occurrence of significant stress levels, by either or both of the following:

- suitable reduction of the allowable stress levels for combined loadings (see [5]);
- detailed investigation of the fatigue behaviour.

Particular attention is to be given to the details of structural design in critical areas such as bracing members, joint connections, etc.

7.2 Wave clearance of upper deck

7.2.1 (1/7/2015)

Unless deck structures are designed for wave impact, a clearance acceptable to the Society, taking account of

anticipated unit movements, is to be maintained between passing wave crests and the deck structure.

The Society is to be provided with model test data, reports on past operating experience with similar configurations or calculations showing that adequate provision is made to maintain this clearance.

7.3 Upper deck

7.3.1 (1/7/2015)

The scantlings of the upper structure are not to be less than those required by Part B, considering the upper deck as the strength deck of a unit, for the loading shown in the deck loading plan.

These loadings are to be not less than the minima specified in [3.3].

In addition, when the upper deck structure is considered to be an effective member of the overall structural frame of the unit, the scantlings are to be sufficient to withstand actual local loadings plus any additional loadings superimposed by the primary structures of the unit, within the stress limitations given in [5].

7.3.2 (1/7/2015)

When an approved mode of operation or damage condition in accordance with the stability requirements allows the upper structure to become waterborne, special consideration is to be given to the resulting structural loading.

7.4 Columns, lower hulls and footings

7.4.1 (1/7/2015)

The scantlings of columns, lower hulls and footings are to be based on the evaluation of hydrostatic pressure loading and combined loading including wave and current considerations..

7.4.2 (1/7/2015)

Main stability columns, lower hulls or footings may be designed as either framed or unframed shells.

In either case, framing, ring stiffeners, bulkheads or other suitable diaphragms which are used are to be sufficient to maintain shape and stiffness under all the anticipated loadings.

7.4.3 (1/7/2015)

Where columns, lower hulls or footings are designed with stiffened plating, the minimum scantlings of plating, framing, girders, etc. may be determined in accordance with the requirements for tanks.

The design head to be used for subdivision bulkheads is that corresponding to the final waterline of the unit in damaged condition.

The scantlings of shell plates and associated stiffeners of columns, lower hulls and footings are to be calculated either as above for subdivision bulkheads, or as tank bulkheads with a head corresponding to the maximum allowable waterline for intact condition, adopting the more severe scantling. The stiffeners of external shells of columns and of the upper hull are also to be verified as side or superstructure stiffeners, as appropriate.

In addition, the scantlings of bulkheads bounding a tank are to be calculated as for tank bulkheads with internal head.

7.4.4 (1/7/2015)

Where columns, lower hulls or footings are designed as shells, either unstiffened or ring stiffened, the minimum scantlings of shell plating and ring stiffeners are to be determined on the basis of established shell analysis using the appropriate safety factors and the design heads as given in [7.4.3].

7.4.5 (1/7/2015)

Scantlings of columns, lower hulls or footings as determined in [7.4.3] and [7.4.4] are minimum requirements for hydrostatic pressure loads.

Where wave and current forces are superimposed, the local structure of the shell is to be increased in scantlings as necessary to meet the strength requirements of [2.4].

7.4.6 (1/7/2015)

Where a column, lower hull or footing is a part of the overall structural frame of a unit, consideration is also to be given to stresses resulting from deflections due to the applicable combined loading.

7.4.7 (1/7/2015)

Particular consideration is to be given to structural arrangements and details in areas subject to high local loading resulting from, for example, external damage (collisions, grounding, etc.), wave impact, partially filled tanks, bottom bearing operations or continuity through joints.

7.4.8 (1/7/2015)

When a unit is designed for operations while supported by the sea-bed, the footings are to be designed to withstand the shock of bottom contact due to wave action on the hull.

Such units are also to be evaluated for the effects of possible scouring action (loss of bottom support).

As a first approach the scouring effects may be evaluated as follows:

- a) for units designed to rest on a single large footing, a non-bearing area equal to 20% of the area covered by the footing is considered;
- b) when two or more footings are provided, the area of each footing resting on the sea-bed shall be considered not greater than 50% of its bearing surface.

The non-bearing areas are to be located in the most severe positions for unit safety.

The effect of skirt plates, or any other arrangement to prevent loss of sea-bed bearing capacity, is to be given special consideration.

7.4.9 (1/7/2015)

The structure in way of components of the position mooring system such as fairleads and winches is to be de-signed to withstand the stresses imposed when a mooring line is loaded to its breaking strength.

7.5 Bracing members

7.5.1 (1/7/2015)

Bracing members are to be designed to make the structure effective against applicable combined loading, and when the unit is supported by the sea-bed, against the possibility of uneven bottom bearing loading.

Bracing members are to be capable to withstand, where applicable, the combined stresses including local bending stresses due to buoyancy, wave forces and current forces.

7.5.2 (1/7/2015)

Where applicable special consideration is to be given to local stresses caused by wave impact.

7.5.3 (1/7/2015)

Where bracings are watertight they are to be designed to prevent collapse from hydrostatic pressure.

Underwater bracing are normally to be made watertight and have a leak detection system to make it possible to detect fatigue cracks at an early stage.

7.5.4 (1/7/2015)

Consideration is to be given to the need for ring frames to maintain stiffness and shape in tubular bracing members.

7.6 Structural redundancy

7.6.1 (1/7/2015)

The unit's structure is to be able to withstand the loss of any slender bracing member without causing overall collapse when exposed to environmental loading corresponding to a one-year return period for the intended area of operation.

Structural redundancy is to be based on the applicable requirements of [3], [4], [5] and [1.2.2]. Maximum calculated stresses in the structure remaining after the loss of a slender bracing member are to be in accordance with [5] in

association with safety factors not less than 1,0 and permissible stresses not greater than yielding or buckling stresses.

This criteria may be exceeded for local areas, provided redistribution of forces due to yielding or buckling is taken into consideration.

7.6.2 (1/7/2015)

The structural arrangement of the upper hull is to be considered with regard to the structural integrity of the unit after the assumed failure of any primary girder. The Society may require a structural analysis showing satisfactory protection against overall collapse of the unit after such an assumed failure when exposed to environmental loading corresponding to a one-year return period for the intended area of operation.

7.7 Fatigue analysis

7.7.1 (1/7/2015)

The possibility of fatigue damage due to cyclic loading is to be considered in the design of column-stabilized units.

The fatigue analysis is to be based on the intended mode and area of operations to be considered in the unit's design.

The fatigue analysis is to take into account the intended design life and the accessibility of individual structural members for inspection.

SECTION 3

STABILITY

1 General

1.1 Application

1.1.1 (1/7/2015)

Requirements contained in this Section are additional to those contained in Part B, Chapter 3, except for Item [2] that is to be applied in lieu of Pt B, Ch 3, Sec 1, [2.2].

1.1.2 (1/7/2015)

All units are to have positive stability in calm water equilibrium position, for the full range of draughts when in all modes of operation afloat, and for temporary positions when raising or lowering.

In addition, all units are to meet the stability requirements set forth below for all applicable conditions.

1.2 Document to be submitted

1.2.1 (1/7/2015)

The stability documentation to be submitted for approval is as follows:

- damage stability calculations,
- damage control documentation.

1.2.2 (1/7/2015)

A copy of the documentation as per [1.2.1] is to be available on board for the attention of the Master.

2 Inclining test

2.1

2.1.1 (1/7/2015)

An inclining test is to be required for the first unit of a design, when the unit is as near to completion as possible, to determine accurately the light ship data (weight and position of centre of gravity).

The test procedure is to be submitted to the Society for approval prior to the test.

2.1.2 (1/7/2015)

For successive units which are identical by design, the light ship data of the first unit of the series may be accepted by the Society in lieu of an inclining test, provided the difference in light ship displacement or position of centre of gravity due to weight changes for minor differences in machinery, outfitting or equipment, confirmed by the results of a deadweight survey, is less than 1% of the values of the light ship displacement and principal horizontal dimensions as determined for the first of the series. Extra care is to be given to the detailed weight calculation and comparison with the original unit of a series of column-stabilized, semi-submersible types as these, even though identical by design, are recognized as being unlikely to attain an acceptable similarity of weight or centre of gravity to warrant a waiver of the inclining test.

2.1.3 (1/7/2015)

The results of the inclining test, or deadweight survey and inclining experiment adjusted for weight differences, are to be indicated in the Operating Manual.

2.1.4 (1/7/2015)

A record of all changes to machinery, structure, outfitting and equipment that affect the light ship data, is to be maintained in the Operating Manual or in a light ship data alterations log and be taken into account in daily operations.

2.1.5 (1/7/2015)

For column-stabilized units, a deadweight survey is to be conducted at intervals not exceeding 5 years. Where the deadweight survey indicates a change from the calculated light ship displacement in excess of 1% of the operating displacement, an inclining test is to be conducted.

2.1.6 (1/7/2015)

The inclining test or deadweight survey is to be attended by a Surveyor of the Society. The Society may accept inclining tests or lightweight checks attended by a member of the flag Administration..

2.1.7 (1/7/2015)

For units which have undergone work of minor importance and for which the weights and the centres of gravity of shipped and unshipped loads are known, the new displacement and centre of gravity obtained from calculation carried out on the basis of the original data are deemed satisfactory.

3 Righting moment and heeling moment curves

3.1

3.1.1 (1/7/2015)

Righting moment curves and wind heeling moment curves related to the most critical axis, with supporting calculations, are to be prepared for a sufficient number of conditions covering the full range of draughts corresponding to afloat modes of operation (see Fig. 1). In all cases, except column stabilized units, the area under the righting moment curve to the second intercept or downflooding angle, whichever is less, is not to be less than 40% in excess of the area under the wind heeling moment curve to the same limiting angle. For column stabilized units, the area under the righting moment curve to the angle of downflooding is not to be less than 30% in excess of the area under the wind heeling moment curve to the same limiting angle. In all cases, the righting moment curve is to be positive over the entire range of angles from upright to the second intercept.

3.1.2 (1/7/2015)

- a) The curves of wind heeling moments are to be drawn for wind forces calculated by the following formula:

$$F = 0,5 C_s \cdot C_H \cdot r \cdot V^2 \cdot A$$

where:

- A : the wind force, in N;
 C_s : the shape coefficient depending on the shape of the structural member exposed to the wind (see Tab 1);
 C_H : the height coefficient depending on the height above sea level of the structural member exposed to wind (see Tab 2);
R : the air mass density (1,222 kg/m³);
V : the wind velocity, in m/s;
A : the projected area of all exposed surfaces in either the upright or the heeled condition, in m².

Shapes or combinations of shapes which do not readily fall into the specified categories will be subject to special consideration by the Society.

- b) Wind forces should be considered in any direction relative to the unit realistic operating conditions are to be evaluated as follows:
- 1) The unit is to be capable of remaining in the operating mode with a sustained wind velocity of not less than 36 m/s (70 knots).
 - 2) The capability is to be provided to change the mode of operation of the unit to that corresponding to a severe storm condition, with a sustained wind velocity of not less than 51,5 m/s (100 knots), in a reasonable period of time for the particular unit.
 - 3) In all cases, the limiting wind velocities are to be specified and instructions are to be included in the Operating Booklet for changing the mode of operation by redistribution of the variable load and equipment, by changing draughts, or both.
 - 4) For restricted operations consideration may be given to a reduced sustained wind velocity of not less than 25,8 m/s (50 knots). Particulars of the applicable service restrictions are to be recorded in the Operating Booklet. For the purpose of calculation it is to be assumed that the unit is floating free of mooring restraints.
- c) In calculating the projected areas to the vertical plane, the area of surfaces exposed to wind due to heel or trim, such as under-deck surfaces, etc., is to be included using the appropriate shape factor. Open truss work may be approximated by taking 30% of the projected block area of both the front and back section, i.e. 60% of the projected block area of one side.
- An appropriate shape coefficient is to be taken from Tab 1.

Table 1 : Values of the shape coefficient
 C_s (1/7/2015)

Shape	C_s
Spherical	0,4
Cylindrical	0,5

Shape	C_s
Large flat surfaces (hull, deckhouse, smooth under-deck areas)	1,0
Wires	1,2
Exposed beams and girders under deck	1,3
Small parts	1,4
Isolated shapes (crane, beam, etc.)	1,5
Clustered deckhouses or similar structures	1,1

Table 2 : Values of the height coefficient
 C_H (1/7/2015)

Height above sea level (m)	C_H
0 - 15,3	1,0
15,3 - 30,5	1,10
30,5 - 46,0	1,20
46,0 - 61,0	1,30
61,0 - 76,0	1,37
76,0 - 91,5	1,43
91,5 - 106,5	1,48
106,5 - 122,0	1,52
122,0 - 137,0	1,56
137,0 - 152,5	1,60
152,5 - 167,5	1,63
167,5 - 183,0	1,67
183,0 - 198,0	1,70
198,0 - 213,5	1,72
213,5 - 228,5	1,75
228,5 - 244,0	1,77
244,0 - 256,0	1,79
above 256	1,80

- d) In calculating the wind forces, the following procedures are recommended:
- 1) in the case of units with columns, the projected areas of all columns are to be included; i.e. no shielding allowance is to be taken;
 - 2) the block projected area of a clustering of deckhouses may be used in lieu of the calculation of each individual area. The shape coefficient may be assumed to be 1,1;
 - 3) isolated houses, structural shapes, cranes, etc. are to be calculated individually, using the appropriate shape coefficient.

3.1.3 (1/7/2015)

In calculating the wind heeling moments, the lever of the wind overturning force is to be taken vertically from the centre of pressure of all surfaces exposed to the wind to the centre of lateral resistance or, if available, the centre of hydrodynamic pressure, of the underwater body of the unit. The unit is to be assumed floating free of mooring restraint.

However, the possible detrimental effects of mooring restraints is to be considered.

3.1.4 (1/7/2015)

The wind heeling moment curve is to be calculated for a sufficient number of heel angles to define the curve. For ship-shaped hulls the curve may be assumed to vary as the cosine function of vessel heel.

3.1.5 (1/7/2015)

Wind heeling moments derived from wind tunnel tests on a representative model of the unit may be considered as alternatives to the method given in [3.1.2] to [3.1.4]. Such heeling moment determination is to include lift and drag effects at various applicable heel angles.

4 Intact stability criteria

4.1

4.1.1 (1/7/2015)

The stability of a unit in each mode of operation is to meet the following criteria (see also Fig 1).

- a) For surface units the area under the righting moment curve to the second intercept or downflooding angle, whichever is less, is to be not less than 40% in excess of the area under the wind heeling moment curve to the same limiting angle;
- b) For column-stabilized units the area under the righting moment curve to the angle of downflooding is to be not less than 30% in excess of the area under the wind heeling moment curve to the same limiting angle.
- c) The righting moment curve is to be positive over the entire range of angles from upright to the second intercept.
- d) A check is to be carried out to assess that the lesser of the downflooding angle and the second intercept angle is not greater than the following angles:
 - 1) the angle for which the stresses of whichever primary structural element become excessive;
 - 2) the limit angle for which lashes of loads on the decks are calculated.

4.1.2 (1/7/2015)

Each unit is to be capable of attaining a severe storm condition in a period of time consistent with the meteorological conditions. The procedures recommended and the approximate length of time required, considering both operating conditions and transit conditions, are to be contained in the Operating Manual.

It is to be possible to achieve the severe storm condition without the removal or relocation of solid consumables or other variable load. However, the Society may permit loading a unit past the point at which solid consumables would have to be removed or relocated to go to severe storm condition under the following conditions, provided the allowable KG requirement is not exceeded:.

- a) in a geographic location where weather conditions annually or seasonally do not become sufficiently

severe to require a unit to go to severe storm condition, or

- b) where a unit is required to support extra deckload for a short period of time that falls well within a period for which the weather forecast is favourable.

The geographic locations, weather conditions and loading conditions in which this is permitted are to be identified in the Operating Manual.

4.1.3 (1/7/2015)

Alternative stability criteria may be considered by the Society provided an equivalent level of safety is maintained and if they are demonstrated to afford adequate positive initial stability. In determining the acceptability of such criteria, the Society may consider at least the following and take into account as appropriate:

- a) environmental conditions representing realistic winds (including gusts) and waves appropriate for world-wide service in various modes of operation;
- b) dynamic response of a unit. Analysis is to include the results of wind tunnel tests, wave tank model tests, and non-linear simulation, where appropriate. Any wind and wave spectra used is to cover sufficient frequency ranges to ensure that critical motion responses are obtained;
- c) potential for flooding taking into account dynamic responses and wave profile in a seaway;
- d) susceptibility to capsizing considering the unit's restoration energy and the static inclination due to the mean wind speed and the maximum dynamic response;
- e) an adequate safety margin to account for uncertainties;
- f) equivalent damage and flooding criteria (see Appendix 4).

Figure 1 : Righting moment and heeling moment curves (1/7/2015)

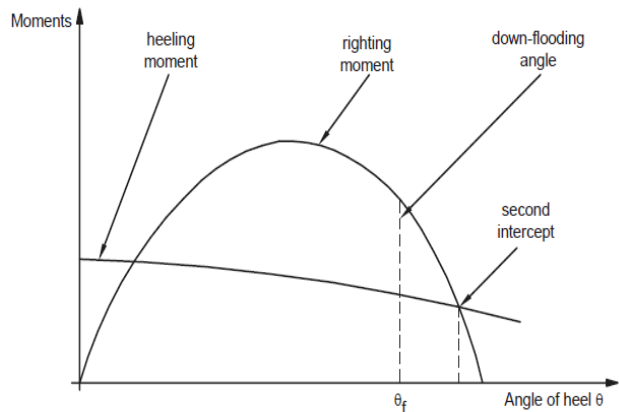

Area (A + B) > 1,4 or 1,3 Area (B + C)

5 Subdivision and damage stability

5.1 Surface units

5.1.1 (1/7/2015)

The unit is to have sufficient freeboard and be subdivided by means of watertight decks and bulkheads to provide suf-

ficient buoyancy and stability to withstand the flooding from the sea of any single compartment or any combination of compartments in any operating or transit condition consistent with the damage assumptions set out in item [6].

5.1.2 (1/7/2015)

The unit is to have sufficient reserve stability in a damaged condition to withstand the wind heeling moment based on a wind velocity of 25,8 m/s (50 knots) superimposed from any direction. In this condition the final waterline, after flooding, is to be below the lower edge of any downflooding opening.

5.1.3 (1/7/2015)

Surface type units are to have sufficient stability as per [5.1.1], such that the final waterline is located below the lower edge of any opening that does not meet the watertight integrity requirements of [8.2.2].

5.2 Column-stabilized units

5.2.1 (1/7/2015)

The unit is to have sufficient freeboard and be subdivided by means of watertight decks and bulkheads to provide sufficient buoyancy and stability to withstand a wind heeling moment induced by a wind velocity of 25,8 m/s (50 knots) superimposed from any direction in any operating or transit condition, taking the following considerations into account:

- inclination after the damage set out in [6.2.1], b) is to not be greater than 17°;
- any opening below the final waterline is to be made watertight, and openings within 4 m above the final waterline are to be made weathertight;
- the righting moment curve, after the damage set out above, is to have, from the first intercept to the lesser of the extent of weathertight integrity required by b) and the second intercept, a range of at least 7°.

Within this range, the righting moment curve is to reach a value of at least twice the wind heeling moment curve, both being measured at the same angle (see Fig 2 below).

For alternative criteria see App 3.

5.2.2 (1/7/2015)

The unit is to provide sufficient buoyancy and stability in any operating or transit condition with the assumption of no wind to withstand the flooding of any watertight compartment wholly or partially below the waterline in question, which is a pump-room, a room containing machinery with a salt water cooling system or a compartment adjacent to the sea, taking the following considerations into account:

- the angle of inclination after flooding is to not be greater than 25°;
- any opening below the final waterline is to be made watertight;
- a range of positive stability is to be provided, beyond the calculated angle of inclination in these conditions, of at least 7°.

For alternative criteria see App 3.

5.2.3 (1/7/2015)

Column stabilized units are to have sufficient stability as per [5.2.1] such that:

- the final waterline is located below the lower edge of any opening that does not meet the watertight integrity

requirements of 8.2.2 (Attention is drawn to 3.4.3 of the 2009 IMO MODU Code [Res A.1023(26)] which limits the inclination of the unit relative to this final waterline, to be not greater than 17 degrees. Refer to Fig.2. Compliance with this limitation may be required by some Administrations).

- within the provided extent of weathertight integrity the damage righting moment curve is to have a range of at least 7 degrees beyond its first intercept with the 25,8 m/sec (50 knots) wind heeling moment curve to its second intercept or downflooding angle, whichever is less.

Further, the damage righting moment curve is to reach a value of at least twice the wind heeling moment curve, both measured at the same angle. Refer to Fig 2.

- openings within 4 m above the final waterline are to be made weathertight.

Figure 2 : Residual damage stability requirements for column stabilized units (1/7/2015)

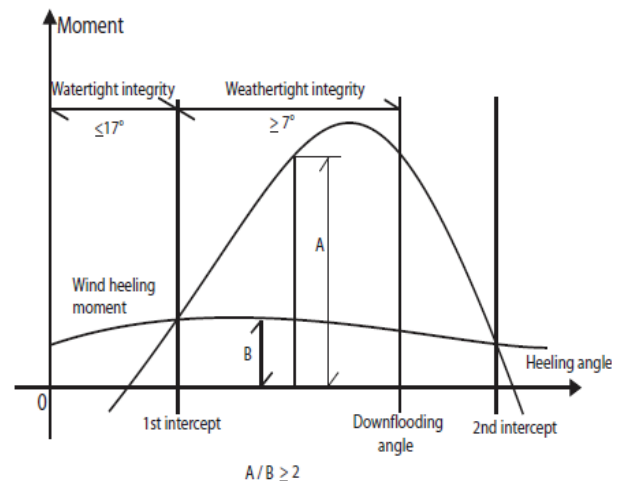

5.2.4 (1/7/2015)

Column stabilized units are to have sufficient stability as per [5.2.2] such that:

- the equilibrium waterline is located below the lower edge of any opening that does not meet the watertight integrity requirements of [8.2.2] (Attention is drawn to 3.4.4 of the 2009 IMO MODU Code [Res A.1023(26)] which limits the inclination of the unit, relative to this equilibrium waterline, to be not greater than 25 degrees. Compliance with this limitation may be required by some Administrations).
- sufficient margin of stability is provided. (Attention is drawn to 3.4.4 of the 2009 IMO MODU Code [Res A.1023(26)] which requires a range of positive stability of at least 7 degrees beyond the first intercept of the righting moment curve and the horizontal coordinate axis of the static stability curve to the second intercept of them or the downflooding angle, whichever is less. Compliance with this range may be required by some Administrations).

Further, the damage righting moment curve is to reach a value of at least twice the wind heeling moment curve, both measured at the same angle. Refer to Fig 2.

5.3 All types of units

5.3.1 (1/7/2015)

a) Compliance with the requirements of items [5.1] and [5.2] is to be determined by calculations which take into consideration the proportions and design characteristics of the unit and the arrangements and configuration of the damaged compartments. In making these calculations, it is to be assumed that the unit is in the worst anticipated service condition as regards stability and is floating free of mooring restraints.

However, the possible detrimental effects of mooring restraints are to be considered.

- b) The ability to reduce angles of inclination by pumping out or ballasting compartments or application of mooring forces, etc., is not to be considered as justifying any relaxation of the requirements.
- c) For the purpose of stability calculations, tanks whose vents or overflows terminate on open decks or in locations assumed flooded, or in any event not above the final calculated water line in damage conditions, are to be considered flooded. Where the tanks are considered flooded, the locations where their vents and/or overflows terminate are also to be assumed flooded.

5.4

5.4.1 (1/7/2015)

Alternative subdivision and damage stability criteria may be considered for approval by the Society provided an equivalent level of safety is maintained. In determining the acceptability of such criteria, the Society may consider at least the following and take into account:

- a) extent of damage as set out in item [6];
- b) on column-stabilized units, the flooding of any one compartment as set out in item [5.2.2];
- c) the provision of an adequate margin against capsizing.

6 Extent of damage

6.1 Surface units

6.1.1 (1/7/2015)

In assessing the damage stability of surface units, the following extent of damage is to be assumed to occur between effective watertight bulkheads:

- a) horizontal penetration: 1,5 m; and
- b) vertical extent: from the base line upwards without limit.

6.1.2 (1/7/2015)

The distance between effective watertight bulkheads or their nearest stepped portions which are positioned within the assumed extent of horizontal penetration is to be not less than 3,0 m; where there is a lesser distance, one or more of the adjacent bulkheads is to be disregarded.

6.1.3 (1/7/2015)

Where damage of a lesser extent than in item [6.1.1] results in a more severe condition, such lesser extent is to be assumed.

6.1.4 (1/7/2015)

All piping, ventilation systems, trunks, etc., within the extent of damage referred to in item [6.1.1] are to be assumed to be damaged. Positive means of closure are to be provided at watertight boundaries to preclude the progressive flooding of other spaces which are intended to be intact.

In addition, the compartments bounded by the bottom shell are to be considered flooded individually.

6.2 Column-stabilized units

6.2.1 (1/7/2015)

In assessing the damage stability of column-stabilized units, the following extent of damage is to be assumed:

- a) Only those columns, underwater hulls and braces on the periphery of the unit are to be assumed to be damaged and the damage is to be assumed in the exposed portions of the columns, underwater hulls and braces.
- b) Columns and braces are to be assumed to be flooded by damage having a vertical extent of 3,0 m occurring at any level between 5,0 m above and 3,0 m below the draughts specified in the Operating Manual. Where a watertight flat is located within this region, the damage is to be assumed to have occurred in both compartments above and below the watertight flat in question. Lesser distances above or below the draughts may be applied to the satisfaction of the Society, taking into account the actual operating conditions.

However, the required damage region is to extend at least 1,5 m above and below the draught specified in the Operating Manual.

- c) No vertical bulkhead is to be assumed to be damaged, except where bulkheads are spaced closer than a distance of one eighth of the column perimeter at the draught under consideration, measured at the periphery, in which case one or more of the bulkheads is to be disregarded.
- d) Horizontal penetration of damage is to be assumed to be 1,5 m.
- e) Underwater hull or footings are to be assumed to be damaged when operating in a transit condition in the same manner as indicated in a), b), d) and c), having regard to their shape.
- f) All piping, ventilation systems, trunks, etc., within the extent of damage are to be assumed to be damaged. Positive means of closure are to be provided at watertight boundaries to preclude the progressive flooding of other spaces which are intended to be intact.

In addition, the compartments bounded by the bottom shells are to be considered flooded individually.

- g) If damage of a lesser extent results in a more severe final equilibrium condition, such lesser extent is to be assumed.

7 Watertight integrity

7.1 General

7.1.1 (1/7/2015)

All units are to be provided with watertight bulkheads. In all cases, the plans submitted are to clearly indicate the location and extent of the bulkheads.

7.1.2 (1/7/2015)

Watertight subdivision bulkheads are to have scantlings as required assuming a head equal to the greatest water head relevant to the unit in damage conditions.

7.1.3 (1/7/2015)

Where watertight boundaries are required for damage stability, they are to be made watertight throughout, including piping, ventilation, shafting, electrical penetrations, etc. For compliance with the requirements of damage stability, where individual lines, ducts or piping systems serve more than one compartment or are within the extent of damage, satisfactory arrangements are to be provided to preclude the possibility of progressive flooding through the system to other spaces, in the event of damage.

7.1.4 (1/7/2015)

The number of openings in watertight subdivisions is to be kept to a minimum compatible with the design and proper working of the unit. Where penetrations of watertight decks and bulkheads are necessary for access, piping, ventilation, electrical cables, etc., arrangements are to be made to maintain the watertight integrity of the enclosed compartments.

7.1.5 (1/7/2015)

Where valves are provided at watertight boundaries to maintain watertight integrity, these valves are to be capable of being operated from a pump-room or other normally manned space, a weather deck, or a deck which is above the final waterline after flooding.

In the case of a column-stabilized unit this would be the central ballast control station.

Valve position indicators are to be provided at the remote control station.

7.1.6 (1/7/2015)

In the case of column-stabilized production units, the scantlings of the watertight flats and bulkheads are to be made effective to that point necessary to meet the requirements of damage stability and are to be indicated on the appropriate plans.

7.1.7 (1/7/2015)

All surface type units are to be fitted with a collision bulkhead. Sluice valves, cocks, manholes, watertight doors, etc. are not to be fitted in the collision bulkhead.

Elsewhere, watertight bulkheads are to be fitted as necessary to provide transverse strength and subdivision.

7.2 Tank boundaries

7.2.1 (1/7/2015)

Tanks for fresh water or fuel oil, or any other tanks which are not intended to be kept entirely filled in service, are to have divisions or deep swashes as may be required to minimize the dynamic stress on the structure. Tight divisions and

boundary bulkheads of all tanks are to be constructed in accordance with Tasneef Rules.

The arrangement of all tanks, together with their intended service and the height of the overflow pipes, is to be clearly indicated on the plans submitted for approval.

Consideration is to be given to the density of the liquid in the tank.

7.2.2 (1/7/2015)

Tanks are to be tested in accordance with Part A depending on the service of the tanks.

8 Closing appliances

8.1 General requirements related to intact stability

8.1.1 (1/7/2015)

Closing appliances are to be as required by applicable load line requirements, except that special consideration will be given to openings in the upper deck of the upper hull of column-stabilized production units.

8.2 General requirements related to damage stability

8.2.1 (1/7/2015)

a) The means to ensure the watertight integrity of internal openings are to comply with the following:

- 1) Doors and hatch covers which are used during the operation of the unit while afloat are to be remotely controlled from the central ballast control station and are also to be operable locally from each side.

Open/shut indicators are to be provided at the control station.

In addition, remotely operated doors provided to ensure the watertight integrity of internal openings which are used while at sea are to be sliding watertight doors with audible alarm. The power, control and indicators are to be operable in the event of main power failure. Particular attention is to be paid to minimizing the effect of control system failure. Each power-operated sliding watertight door shall be provided with an individual handoperated mechanism. It shall be possible to open and close the door by hand at the door itself from both sides.

- 2) Doors or hatch covers in self-elevating units, or doors placed above the deepest load line draft in column-stabilized and surface units, which are normally closed while the unit is afloat may be of the quick acting type and should be provided with an alarm system (e.g., light signals) showing personnel both locally and at the central ballast control station whether the doors or hatch covers in question are open or closed. A notice should be affixed to each such door or hatch cover stating that it is not to be left open while the unit is afloat.
- 3) The closing appliances are to have strength, packing and means for securing which are sufficient to maintain the watertight integrity of the division on which

they are fitted under the design water head of the watertight boundary of the flooded compartment.

- b) The means to ensure the watertight integrity of internal openings are to comply with the following:
- 1) a notice is to be affixed to each such closing appliance stating that it is to be kept closed while the unit is afloat; however, manholes fitted with close bolted covers need not be so marked
 - 2) on surface type and column stabilized units an entry is to be made in the official logbook or tour report, as applicable, stating that all such openings have been witnessed closed before the unit becomes waterborne.
 - 3) the closing appliances are to have strength, packing and means for securing which are sufficient to maintain the watertight integrity of the division on which they are fitted under the design water head of the watertight boundary of the flooded compartment.

- c) All downflooding openings the lower edge of which is submerged when the unit is inclined to the first intercept between the righting moment and wind heeling moment curves in any intact or damaged condition are to be fitted with a suitable watertight closing appliance, such as closely spaced bolted covers.

In any case, the lower edges of air pipes (regardless of closing appliances), ventilators, ventilation intakes and outlets, non-watertight hatches and weathertight doorways are not to be submerged. Openings, such as side scuttles of the non-opening type, manholes and small hatches, which are fitted with appliances to ensure watertight integrity, may be submerged.

Such openings are not allowed in the columns of column-stabilized units.

Such openings are not to be regarded as emergency exits.

External openings, such as air pipes (regardless of closing appliances), ventilators, ventilation intakes and outlets, nonwatertight hatches and weathertight doors, which are used during operation of the unit while afloat, are not to submerge when the unit is inclined to the first intercept of the righting moment and wind heeling moment curves in any intact or damaged condition.

- d) Where flooding of chain lockers or other buoyant volumes may occur, the openings to these spaces are to be considered as downflooding points.

8.2.2 (1/7/2015)

Any opening, such as an air pipe, ventilator, ventilation intake or outlet, non-watertight sidescuttle, small hatch, door, etc., having its lower edge submerged below a waterline associated with the zones indicate in a) or b) below, is to be fitted with a weathertight closing appliance to ensure the weathertight integrity, when:

- a) a unit is inclined to the range between the first intercept of the right moment curve and the wind heeling moment curve and the angle necessary to comply with the requirements of 3.1.1 during the intact condition of the unit while afloat; and

- b) a column stabilized unit is inclined to the range:
- 1) necessary to comply with the requirements of 5.2.3 (b) and with a zone measured 4.0 m perpendicularly above the final damaged waterline per 5.2.3 a) referred to Fig 3, and
 - 2) necessary to comply with the requirements of 5.2.4 b).

External openings fitted with appliances to ensure weathertight integrity, which are kept permanently closed while afloat are to comply with the requirements of [8.2.1], b), 1) and 2).

Figure 3 : Residual damage stability requirements for column stabilized units (1/7/2015)

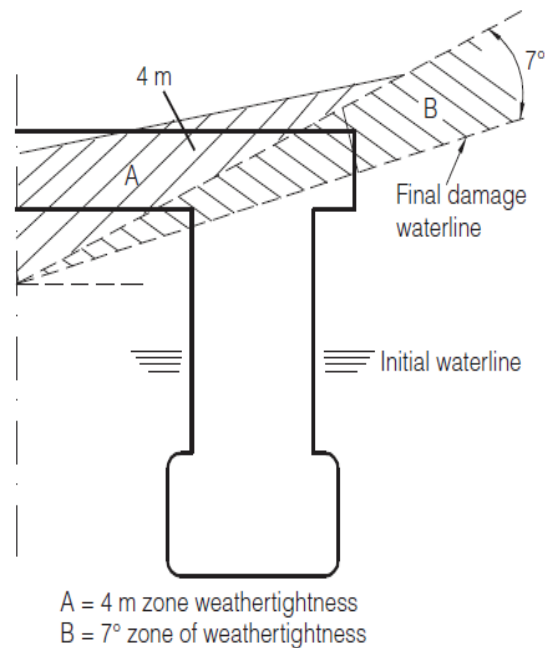

9 Freeboard

9.1 General

9.1.1 (1/7/2015)

The requirements of the 1966 Load Line Convention, including those relating to certification, are to apply to all units and certificates are to be issued as appropriate. The minimum freeboard of units which cannot be computed by the normal methods laid down by that Convention is to be determined on the basis of meeting the applicable intact stability, damage stability and structural requirements for transit conditions. The freeboard is not to be less than that computed from the Convention where applicable.

9.1.2 (1/7/2015)

The requirements of the 1966 Load Line Convention with respect to weathertightness and watertightness of decks, superstructures, deckhouses, doors, hatchway covers, other openings, ventilators, air pipes, scuppers, inlets and discharges, etc., are to be taken as a basis for all units in the floating condition.

9.1.3 (1/7/2015)

In general, heights of hatch and ventilator coamings, air pipes, door sills, etc., in exposed positions and their means of closing are to be determined by consideration of both intact and damage stability requirements.

- a) All downflooding openings which may become submerged before the angle of inclination at which the required area under the intact righting arm curve is achieved are to be fitted with weathertight closing appliances.
- b) With regard to damage stability, the requirements in [5.2.1] b), [5.2.2] and [8.2.1], c) are to apply.
- c) Society is to give special consideration to the position of openings which cannot be closed in emergencies, such as air intakes for emergency generators, having regard to the intact righting arm curves and the final waterline after assumed damage.

9.2 Surface units**9.2.1 (1/7/2015)**

Load lines are to be assigned to surface units as calculated under the terms of the 1966 Load Line Convention and are to be subject to all the conditions of assignment of that Convention.

9.2.2 (1/7/2015)

Where it is necessary to assign a greater than minimum freeboard to meet intact or damage stability requirements or on account of any other restriction imposed by the Society, Regulation 6(6) of the 1966 Load Line Convention is to apply. When such a freeboard is assigned, seasonal marks above the centre of the ring are not to be marked and any seasonal marks below the centre of the ring are to be marked. If a unit is assigned a greater than minimum freeboard at the request of the owner, Regulation 6(6) need not apply.

9.2.3 (1/7/2015)

In cases of small notches or relatively narrow cut-outs within the hull in open communication with the sea, the volume of the cut-out is not to be included in the calculation of any hydrostatic properties. If the cut-out has a larger cross-sectional area above the waterline at 0,85 D than below, an addition is to be made to the geometric freeboard corresponding to the lost buoyancy. This addition for the excess portion above the waterline at 0,85 D is to be made as prescribed below for wells or recesses. If an enclosed superstructure contains part of the cut-out, deduction is to be made for the effective length of the superstructure.

Where open wells or recesses are arranged in the freeboard deck, a correction equal to the volume of the well or recess to the freeboard deck divided by the waterplane area at 0,85 D is to be made to the freeboard obtained after all other corrections, except bow height correction, have been made. Free surface effects of the flooded well or recess are to be taken into account in stability calculations.

9.2.4 (1/7/2015)

Narrow wing extensions at the stern of the unit are to be considered as appendages and excluded for the determination of length (L) and for the calculation of freeboards. The Society is to determine the effect of such wing extensions with regard to the requirements for the strength of unit based upon length (L)..

9.3 Column-stabilized units**9.3.1 (1/7/2015)**

The hull form of this type of unit makes the calculation of geometric freeboard in accordance with the provisions of Chapter III of the 1966 Load Line Convention impracticable.

Therefore the minimum freeboard of each column-stabilized unit is to be determined by meeting the applicable requirements for:

- a) the strength of the unit's structure;
- b) the minimum clearance between passing wave crests and deck structure; and
- c) intact and damage stability requirements.

9.3.2 (1/7/2015)

The minimum freeboard is to be marked in appropriate locations on the structure.

9.3.3 (1/7/2015)

The enclosed deck structure of each column-stabilized unit is to be made weathertight.

9.3.4 (1/7/2015)

Windows, sidescuttles and portlights, including those of the non-opening type, or other similar openings are not to be located below the deck structure of column-stabilized units.

9.3.5 (1/7/2015)

The Society is to give special consideration to the position of openings which cannot be closed in emergencies, such as air intakes for emergency generators, having regard to the intact righting arm curves and the final waterline after assumed damage.

SECTION 4

MACHINERY

1 Machinery installations for all types of units

1.1 General

1.1.1 (1/7/2015)

The requirements of this section apply to MODUs in addition to, and when indicated in lieu of, those in Pt C, Ch 1.

1.1.2 (1/7/2015)

The machinery and electrical requirements contained in this Section provide an acceptable degree of protection for personnel from fire, electric shock or other physical injuries. The requirements apply to both marine and industrial equipment.

1.1.3 (1/7/2015)

Codes and standards of practice which have been proven to be effective by actual application by the offshore industry which are not in conflict with this Code, and which are acceptable to the Society, may be applied in addition to these requirements.

1.1.4 (1/7/2015)

All machinery, electrical equipment, boilers and other pressure vessels, associated piping systems, fittings and wiring are to be of a design and construction adequate for the service for which they are intended and are to be so installed and protected as to reduce to a minimum any danger to persons on board, due regard being paid to moving parts, hot surfaces and other hazards. The design is to have regard to materials used in construction, and to the marine and industrial purposes for which the equipment is intended, the working conditions and the environmental conditions to which it will be subjected.

Consideration is to be given to the consequences of the failure of systems and equipment essential to the safety of the unit.

1.1.5 (1/7/2015)

The requirements of this item apply in lieu of those in Pt C, Ch 1, Sec 1, [2.5] of the Rules for the Classification of Ships. All machinery, components and systems essential to the safe operation of a unit are to be designed to operate under the following static conditions of inclination:

- a) when column-stabilized units are upright and inclined to an angle up to 15° in any direction;
- b) when surface units are upright and in level trim and when inclined to an angle of list up to 15° either way and simultaneously trimmed to an angle up to 5° by the bow or stern.

The Society may permit or require deviations from these angles, taking into consideration the type, size and service conditions of the unit.

1.1.6 (1/7/2015)

Means are to be provided whereby normal operation of vital systems, such as ballast systems in semisubmersible

units, can be sustained or restored even though one of the essential auxiliaries becomes inoperable.

1.1.7 (1/7/2015)

Means are to be provided to ensure that machinery can be brought into operation from the "dead ship" condition without external aid.

1.2 Arrangements for oil fuel, lubricating oil and other flammable oils

1.2.1 (1/7/2015)

The requirements of this item apply in lieu of the ones in Pt C, Ch 1, Sec 1, [2.9] of the Rules for the Classification of Ships.

Flash points mentioned in this subparagraph are intended to be determined by closed cup test.

Where it is intended to burn fuels of a flash point equal to or less than 60°C but not less than 43°C, this fact is to be indicated clearly on the arrangement submitted for approval. Vent heads of an approved type with wire gauze flame arrestors are to be fitted to vent pipes. Consideration may be given to other arrangements. The use of fuels of a flash point lower than 43°C will require special consideration of storage and handling facilities and controls as well as of the electrical installation and ventilation provisions.

1.3 Installation of internal combustion engines and boilers

1.3.1 (1/7/2015)

Generally, combustion engines are not to be installed in hazardous areas. When this cannot be avoided, special consideration may be given to the arrangement.

Fired boilers are not to be installed in hazardous areas.

Exhaust outlets of internal combustion engines are to be fitted with effective spark arresting devices and are to discharge outside hazardous areas.

Exhaust outlets of fired boilers are to discharge outside hazardous areas.

Air intakes for internal combustion engines are to be not less than 3 m from hazardous areas.

1.4 Machinery controls

1.4.1 (1/7/2015)

Machinery essential for the safety of the unit is to be provided with effective means for its operation and control.

1.4.2 (1/7/2015)

Automatic starting, operational and control systems for machinery essential for the safety of the unit are to be in general, include provisions for manually overriding the automatic controls. Failure of any part of the automatic and

remote control system are not to prevent the use of the manual override.

Visual indication is to be provided to show whether or not the override has been actuated.

1.5 Pumping and piping systems

1.5.1 General requirements (1/7/2015)

Pipes are to be arranged inboard of the zone of assumed damage penetration unless special consideration has been taken in the damage stability review.

Piping systems carrying non-hazardous fluids are generally to be separate from piping systems which may contain hazardous fluids. Cross connection of the piping systems may be permitted where means for avoiding possible contamination of the non-hazardous fluid system by the hazardous medium are provided.

1.5.2 Inlet and discharge valves (1/7/2015)

Piping systems carrying non-hazardous fluids are generally to be separate from piping systems which may contain hazardous fluids. Cross connection of the piping systems may be permitted where means for avoiding possible contamination of the non-hazardous fluid system by the hazardous medium are provided.

- a) closing of open valves;
- b) opening of closed valves.

Consideration may be given to accepting bilge alarms in lieu of remote operation for surface type units only.

1.5.3 Steam and air systems (1/7/2015)

Where steam or air is used to atomize well bore fluids prior to flaring, a non-return valve is to be fitted in the steam or air line. This valve is to be part of the permanently installed piping, readily accessible and as close as possible to the burner boom. Alternative arrangements shown to provide an equivalent level of safety may be accepted by the Society.

1.5.4 Bilge systems (1/7/2015)

The requirements in this item apply in lieu of the ones in Pt C, Ch 1, Sec 10, [6.2], [6.3.1], [6.7.1], [6.7.2] and [6.8] of the Rules for the Classification of Ships.

An efficient bilge pumping system is to be provided, capable of pumping from and draining watertight compartments other than spaces permanently appropriated for the carriage of fresh water, water ballast, oil fuel or liquid cargo and for which other efficient means of pumping are provided, under all practical conditions whether the unit is upright or inclined, as specified in [1.1.5].

Additional suction is to be provided in large compartments or compartments of unusual form, as deemed necessary by the Society. Arrangements are to be made whereby water in the compartment may find its way to the suction pipes. Compartments not provided with a bilge suction may be drained to other spaces provided with bilge pumping capability. Means are to be provided to detect the presence of water in such compartments which are adjacent to the

sea or adjacent to tanks containing liquids and in void compartments through which pipes conveying liquids pass.

If the Society is satisfied that the safety of the unit is not impaired, the bilge pumping arrangements and the means to detect the presence of water may be dispensed with in particular compartments.

At least two self-priming power pumps connected to each bilge main are to be provided. Sanitary, ballast and general service pumps may be accepted as independent power bilge pumps if fitted with the necessary connections to the bilge pumping system.

The cross-sectional area of the main bilge line is to be not less than the combined areas of the two largest branch suction.

The internal diameter of branch suction from each compartment is to be not less than the value given by the following formula, to the nearest 5 mm:

$$d = 2,15 \cdot A^{0,5} + 25 \text{ mm}$$

where A is the wetted surface, in m², of the compartment, excluding stiffening members, when the compartment is half-filled with water. The internal diameter of any bilge line is to be not less than 50 mm.

Each bilge pump is to be capable of giving a speed of water through the bilge main of not less than 2 m per second. When more than two pumps are connected to the bilge system, their aggregate capacity is not to be less effective.

Propulsion machinery rooms or pump rooms in lower hulls of column-stabilized units which are normally unattended is to be provided with two independent systems of high level detection.

Hazardous and non-hazardous areas are to be provided with separate drainage or pumping arrangements.

All distribution boxes and manually operated valves in connection with the bilge pumping arrangements are to be in positions which are accessible under ordinary circumstances. Where such valves are located in normally unmanned spaces below the assigned load line and not provided with high bilge water level alarms, they are to be operable from outside the space.

A means to indicate whether a valve is open or closed is to be provided at each location from which the valve can be controlled. The indicator is to rely on movement of the valve spindle.

Drainage of hazardous areas are to be given special consideration having regard to the risk of explosion (see Sec 5, [5.3.9]).

Chainlockers are to be capable of being drained by a permanently installed bilge or drainage system or by portable means. Means are to be provided for removal of mud and debris from the bilge or drainage system.

The following additional requirements are applicable to column-stabilized units.

- a) Chain lockers which, if flooded, could substantially affect the unit's stability are to be provided with a remote means to detect flooding and a permanently installed means of dewatering. Remote indication of

flooding are to be provided at the central ballast control station.

- b) At least one of the pumps referred to above and pump-room bilge suction valves are to be capable of both remote and local operation.
- c) Propulsion rooms and pump-rooms in lower hulls are to be provided with two independent systems for high bilge water level detection providing an audible and visual alarm at the central ballast control station.

1.5.5 Ballast system (1/7/2015)

The requirements in this item apply in lieu of the ones in Pt C, Ch 1, Sec 10, [7] of the Rules for the Classification of Ships.

The unit is to be provided with at least two independently driven ballast pumps for ballasting and de-ballasting of tanks to ensure the safe operation of the unit.

Consideration will be given to alternative arrangements.

The ballast system is to be arranged to prevent the inadvertent transfer of ballast water from one quadrant to any other quadrant of the unit.

Where the pumping arrangement consists of a multiple-pump system, the loss of any one pump are to not prevent the unit being de-ballasted sufficiently to an approved safety position.

Means for ballast control during submersion and raising of column-stabilized units are to be provided; specific instructions are to be included in the Operating Manual.

Control against accidental opening of flooding valves for all modes of operation, including the possible need to blank systems not in use during these operations, are to be provided.

Sea inlets and discharge valves in compartments located below the assigned load line, which generally are not accessible during the normal working conditions, are to be provided with remote controlled valves approved by the Society.

All valves are to be provided with an indicating system showing their effected operations and independent of the valve control.

1.5.6 Ballast pumping arrangements on column-stabilized units (1/7/2015)

The requirements in this item apply in lieu of the ones in Pt C, Ch 1, Sec 10, [7] of the Rules for the Classification of Ships.

Units are to be provided with an efficient pumping system capable of ballasting and deballasting any ballast tank under normal operating and transit conditions. Alternatively, the Society may permit controlled gravity ballasting.

The ballast system is to provide the capability to bring the unit, while in an intact condition, from the maximum nor-

mal operating draught to a severe storm draught, or to a greater distance, as may be specified by the Society, within 3 hours.

The ballast system is to be arranged to provide at least two independent power driven pumps so that the system remains operational in the event of failure of any one such pump. The pumps provided need not be dedicated ballast pumps, but are to be readily available for such use at all times.

The ballast system is to be capable of operating after the damage specified in Sec 3, [6.3] and have the capability of restoring the unit to a level trim and safe draught condition without taking on additional ballast, with any one pump inoperable. The Society may permit counter-flooding as an operational procedure.

The ballast pumps are to be of the self-priming type or be provided with a separate priming system.

The ballast system is to be arranged and operated so as to prevent inadvertent transfer of ballast water from one tank or hull to another, which could result in moment shifts leading to excessive angles of heel or trim.

It is to be possible to supply each required ballast pump from the emergency source of power. The arrangements are to be such that the system is capable of restoring the unit from an inclination specified in [1.1.5], a) to a level trim and safe draught condition after loss of any single component in the power supply system.

All ballast pipes are to be of steel or other suitable material having properties acceptable to the Society. Special consideration is to be given to the design of ballast lines passing through ballast tanks, taking into account effects of corrosion or other deterioration.

All valves and operating controls are to be clearly marked to identify the function they serve. Means are to be provided locally to indicate whether a valve is open or closed.

Air pipes are to be provided on each ballast tank sufficient in number and cross-sectional area to permit the efficient operation of the ballast pumping system. In order to allow deballasting of the ballast tanks intended to be used to bring the unit back to normal draught and to ensure no inclination after damage, air pipe openings for these tanks are to be above the worst damage waterline specified in Sec 3. Such air pipes are to be positioned outside the extent of damage, as defined in Sec 3.

Control and indicating systems are to comply with the following:

- a) A central ballast control station is to be provided. It is to be located above the worst damage waterline and in a space not within the assumed extent of damage referred to in Sec 3 and adequately protected from weather. It is

to be provided with the following control and indicating systems where applicable:

- 1) ballast pump control system;
 - 2) ballast pump status-indicating system;
 - 3) ballast valve control system;
 - 4) ballast valve position-indicating system;
 - 5) tank level-indicating system;
 - 6) draught indicating system;
 - 7) heel and trim-indicators;
 - 8) power availability indicating system (main and emergency);
 - 9) ballast system hydraulic/pneumatic pressure-indicating system.
- b) In addition to remote control of the ballast pumps and valves from the central ballast control station, all ballast pumps and valves are to be fitted with independent local control operable in the event of remote control failure. The independent local control of each ballast pump and of its associated ballast tank valves are to be in the same location.
- c) The control and indicating systems listed in a) are to function independently of one another, or have sufficient redundancy, such that a failure in one system does not jeopardize the operation of any of the other systems.
- d) Each power-actuated ballast valve is to fail to the closed position upon loss of control power. Upon reactivation of control power, each such valve is to remain closed until the ballast control operator assumes control of the reactivated system. The Society may accept ballast valve arrangements that do not fail to the closed position upon loss of power provided the Society is satisfied that the safety of the unit is not impaired.
- e) The tank level indicating system required by a), 5) is to provide means to:
- 1) indicate liquid levels in all ballast tanks. A secondary means of determining levels in ballast tanks, which may be a sounding pipe, is to be provided. Tank level sensors are not to be situated in the tank suction lines;
 - 2) indicate liquid levels in other tanks, such as fuel oil, fresh water or liquid storage tanks, the filling or emptying of which, in the view of the Society, could affect the stability of the unit. Tank level sensors are not to be situated in the tank suction lines
- f) The draught indicating system is to indicate the draught at each corner of the unit or at representative positions as required by the Society.
- g) Enclosures housing ballast system electrical components, the failure of which would cause unsafe operation of the ballast system upon liquid entry into the enclosure, is to comply with Pt C, Ch 2, Sec 2, [7].
- h) A means to indicate whether a valve is open or closed are to be provided at each location from which the

valve can be controlled. The indicators are to rely on movement of the valve spindle.

- i) Means are to be provided at the central ballast control station to isolate or disconnect the ballast pump control and ballast valve control systems from their sources of electrical, pneumatic or hydraulic power.

Internal communication system is to be provided complying with the following a permanently installed means of communication, independent of the unit's main source of electrical power, are to be provided between the central ballast control station and spaces that contain ballast pumps or valves, or other spaces that may contain equipment necessary for the operation of the ballast system.

1.5.7 Protection against flooding (1/7/2015)

Each seawater inlet and discharge in spaces below the assigned load line are to be provided with a valve operable from an accessible position outside the space on:

- a) all column-stabilized units;
- b) all other units where the space containing the valve is normally unattended and is not provided with high bilge water level detection.

The control systems and indicators provided in Sec 3, [8.2.1] are to be operable in both normal conditions and in the event of main power failure. Where stored energy is provided for this purpose, its capacity is to be to the satisfaction of the Society.

1.5.8 Vents and overflows (1/7/2015)

Tank vents and overflows are to be located giving due regard to damage stability and the location of the final calculated waterline in the assumed damage condition.

Tank vents and overflows which could cause progressive flooding are to be avoided unless special consideration has been taken in the damage stability review.

In cases where tank vents and overflows terminate externally or in spaces assumed flooded, the vented tanks are to also be considered flooded.

In cases where tanks are considered damaged, the spaces in which their vents or overflows terminate are to also be considered flooded.

Vents and overflows from tanks not considered flooded as a result of damage and located above the final calculated waterline may be required to be fitted with automatic means of closure.

1.5.9 Sounding arrangements (1/7/2015)

All tanks are to be provided with separate sounding pipes, or approved remote level indicating system.

The internal diameter of sounding pipes is to generally be not less than 38 mm.

Where a sounding pipe exceeds 20 m in length, the minimum internal diameter is to be increased to at least 50 mm.

Where a remote level indicating system is used, an additional sounding system is to be provided for tanks which are not always accessible.

1.6 Position keeping systems and components

1.6.1 Anchoring systems (1/7/2015)

a) General

Plans showing the arrangement and complete details of the anchoring system, including anchors, shackles, anchor lines consisting of chain, wire or rope, together with details of fairleads, windlasses, winches, and any other components of the anchoring system are to be submitted to the Society.

b) Design

1) An analysis of the anchoring arrangements expected to be utilized in the unit's operation are to be submitted to the Society.

Among the items to be addressed are:

- design environmental conditions of waves, winds, currents, tides and ranges of water depth;
- air and sea temperature;
- ice conditions (if applicable);
- description of analysis methodology.

2) Anchoring arrangements, where fitted as the sole means for position keeping, are to be provided with adequate factors of safety and be designed to maintain the unit on station in all design conditions. The arrangements are to be such that a failure of any single component or anchor line are not to cause progressive failure of the remaining anchoring arrangements.

In particular, sufficient numbers of heading angles together with the most severe combination of wind, current and wave are to be considered, usually from the same direction, to determine the maximum tension in each mooring line.

When a particular site is being considered, any applicable cross sea conditions are also to be considered in the event that they might induce higher mooring loads.

3) When the Quasi Static Method is applied, the tension in each anchor line is to be calculated at the maximum excursion for each design condition defined in 4), combining the following steady state and dynamic responses of the unit:

- steady mean offset due to the defined wind, current, and steady wave forces;
- most probable maximum wave induced motions of the moored unit due to wave excitation.

For relatively deep water, the effect from damping and inertia forces in the anchor lines are to be considered in the analysis.

The effects of slowly varying motions are to be included for units when the magnitudes of such motions are considered to be significant.

4) When the Quasi Static Method outlined in 3) is applied, the minimum factors of safety (FOS) at the maximum excursion of the unit for a range of headings (design condition) indicated in Tab 1 are to be considered.

When a dynamic analysis is employed, other safety factors may be considered to the satisfaction of the Society.

The defined operating and severe storm conditions are to be the same as those identified for the design of the unit, unless the Society is satisfied that lesser conditions may be applicable to specific sites.

5) In general, the maximum wave induced motions of the moored unit about the steady mean offset are to be obtained by means of model tests. The Society may accept analytical calculations provided that the proposed method is based on a sound methodology which has been validated by model tests.

In the consideration of column-stabilized units, the values of CS and CH, as indicated in Sec 3, may be introduced in the analysis for position keeping mooring systems.

The provisions of Sec 3, [3.1.5] and [4.1.3] may also be considered.

6) The Society may accept different analysis methodologies provided that it is satisfied that a level of safety equivalent to that obtained by 2) and 4) is ensured.

7) Special consideration is to be given to arrangements where the anchoring systems provided are used in conjunction with thrusters to maintain the unit on station.

Table 1 (1/7/2015)

Design condition	FOS
operating	2,7
severe storm	1,8
operating - one line failed	1,8
severe storm - one line failed	1,25

$FOS = \frac{PB}{T_{max}} = \text{factory of safety}$	
T_{max}	: characteristic tension in the anchor line, equal to the maximum value obtained according to 3)
PB	: minimum rated breaking strength of the anchor line
operating:	the most severe design environmental condition for normal operations as defined by the owner or designer
severe storm:	the most severe design environmental condition for severe storm as defined by the owner or designer.
operating - one line failed:	following the failure of any one mooring line in the operating condition
severe storm - one line failed:	following the failure of any one mooring line in the severe storm condition.

1.6.2 Equipment (1/7/2015)

a) Windlasses

1) The design of the windlasses is to provide for adequate dynamic braking capacity to control normal combinations of loads from the anchor, anchor cable and anchor handling vessel during the deploy-

ment of the anchors at the maximum design payout speed of the windlass.

The attachment of the windlass to the hull structure is to be designed to withstand the breaking strength of the anchor line

- 2) Each windlass is to be provided with two independent power-operated brakes. Each brake is to be capable of holding against a static load in the anchor cable of at least 50% of its breaking strength.

Where the Society so allows, one of the brakes may be replaced by a manually operated brake.

- 3) On loss of power to the windlasses, the power-operated braking system is to be automatically applied and be capable of holding against 50% of the total static braking capacity of the windlass.

Each windlass is to be capable of being controlled from a position which provides a good view of the operation.

b) Fairleads and sheaves

Fairleads and sheaves are to be designed to prevent excessive bending and wear of the anchor cable. The attachments to the hull or structure are to be such as to adequately withstand the stresses imposed when an anchor cable is loaded to its breaking strength.

1.6.3 Anchor line (1/7/2015)

- a) It is to be ensured that the anchor lines are of a type that will satisfy the design conditions of the anchoring system.
- b) Means are to be provided to enable the anchor cable to be released from the unit after loss of main power.
- c) Means are to be provided for measuring anchor line tensions.
- d) Anchor lines are to be of adequate length to prevent uplift of the anchors under the maximum design conditions for the anticipated area(s) of operation.

1.6.4 Anchors (1/7/2015)

- a) Type and design of anchors are to be to the satisfaction of the Society.
- b) Suitable anchor stowage arrangements are to be provided to prevent movement of the anchors in a seaway.

1.6.5 Quality control (1/7/2015)

- a) Details of the quality control of the manufacturing process of the individual anchoring system components are to be submitted.
- b) The anchors, cables, shackles and other associated connecting equipment are to be designed, manufactured and tested in accordance with a recognized standard.

Evidence, to the satisfaction of the Society, that the equipment has been so tested and approved are to be

readily available. Provisions are to be made on board for the recording of changes to and inspection of the equipment. Anchor cables may be of wire, rope, chain or any combination thereof.

1.6.6 Control stations (1/7/2015)

- a) A manned control station is to be provided with means to:
 - 1) indicate cable tension; and
 - 2) indicate speed and direction of wind.
- b) Reliable means are to be provided to communicate between locations critical to the anchoring operation.
- c) Means are to be provided at the windlass control position to:
 - 1) monitor cable tension and windlass power load; and
 - 2) indicate the amount of cable paid out.

1.6.7 Dynamic positioning systems (1/7/2015)

Dynamic positioning systems used as a sole means of position keeping are to provide a level of safety equivalent to that provided for anchoring arrangements (see Note 1).

Units provided with position keeping systems equipment in accordance with the Pt F, Ch 6, Sec 2 may obtain the additional class notation **DYNAPOS**.

Note 1: Reference is made to the "Guidelines for Vessels with Dynamic Positioning Systems" approved by the Maritime Safety Committee of IMO at its 63rd session and disseminated by circular MSC/Circ. 645.

2 Additional requirements for machinery and electrical installations of self-propelled units

2.1 General

2.1.1 (1/7/2015)

The requirements of this Chapter apply to units which are designed to undertake self-propelled passages without external assistance and are not applicable to units which are fitted only with means for the purpose of positioning or of assistance in towing operations. These requirements are additional to those in [1].

2.1.2 (1/7/2015)

For propulsion system reference is to be made to the relevant rule requirements of Pt C, Ch 1 of the Rules for Classification of Ships.

2.1.3 (1/7/2015)

Means are to be provided whereby normal operation of propulsion machinery can be sustained or restored even

though one of the essential auxiliaries becomes inoperative. Special consideration is to be given to the malfunction of:

- a) a generator set which serves as a main source electrical power;
- b) the sources of steam supply;
- c) the arrangements for boiler feedwater;
- d) the arrangements which supply fuel oil for boilers or engines;
- e) the sources of lubricating oil pressure;
- f) the sources of water pressure;
- g) a condensate pump and the arrangements to maintain vacuum in condensers;
- h) the mechanical air supply for boilers;
- i) an air compressor and receiver for starting or control purposes; and
- j) the hydraulic, pneumatic or electrical means for control in main propulsion machinery including controllable pitch propellers.

However, the Society, having regard to overall safety considerations, may accept a partial reduction in capability from full normal operation.

2.1.4 (1/7/2015)

Main propulsion machinery and all auxiliary machinery essential to the propulsion and the safety of the unit are to be fitted in the unit, be capable of operating under the static conditions required by [1.1.5] and the following dynamic conditions:

- a) column-stabilized unit; 22,5° in any direction;
- b) surface units 22,5° rolling and simultaneously pitching 7,5° by bow or stern.

The Society may permit deviation from these angles, taking into consideration the type, size and service conditions of the unit.

2.1.5 (1/7/2015)

Special consideration is to be given to the design, construction and installation of propulsion machinery systems so that any mode of their vibrations does not cause undue stresses in this machinery in the normal operating ranges.

2.2 Means of going astern

2.2.1 (1/7/2015)

Units are to have sufficient power for going astern to secure proper control of the unit in all normal circumstances.

2.2.2 (1/7/2015)

The ability of the machinery to reverse the direction of thrust of the propeller in sufficient time and so to bring the unit to rest within a reasonable distance from maximum ahead service speed is to be demonstrated.

2.2.3 (1/7/2015)

The stopping times, unit headings and distances recorded on trials, together with the results of trials to determine the ability of units having multiple propellers to navigate and manoeuvre with one or more propellers inoperative, are to

be available on board for the use of the master or other designated personnel.

Note 1: Reference is made to the 'Recommendation on the Provision and Display of Manoeuvring Information on Board Ships' adopted by auto with, Resolution A.601 (15).

2.2.4 (1/7/2015)

Where the unit is provided with supplementary means for manoeuvring or stopping, these are to be demonstrated and recorded as referred to in [2.2.2] and [2.2.3].

2.3 Steam boilers and boiler feed systems

2.3.1 (1/7/2015)

Water tube boilers serving turbine propulsion machinery are to be fitted with a high-water-level alarm.

2.3.2 (1/7/2015)

Every steam generating system which provides services essential for the propulsion of the unit is to be provided with not less than two separate feedwater systems from and including the feed pumps, noting that a single penetration of the steam drum is acceptable.

Means are to be provided which will prevent over pressure in any part of the systems.

2.4 Machinery controls

2.4.1 (1/7/2015)

Main and auxiliary machinery essential for the propulsion of the unit are to be provided with effective means for its operation and control. A pitch indicator is to be provided on the navigating bridge for controllable pitch propellers.

2.4.2 (1/7/2015)

Where remote control of propulsion machinery from the navigating bridge is provided and the machinery spaces are intended to be manned, the following are to apply:

- a) the speed, direction of thrust and, if applicable, the pitch of the propeller are to be fully controllable from the navigating bridge under all sailing condition, including manoeuvring;
- b) the remote control is to be performed, for each independent propeller, by a control device so designed and constructed that its operation does not require particular attention to the operational details of the machinery. Where more than one propeller is designed to operate simultaneously, these propellers may be controlled by one control device;
- c) the main propulsion machinery is to be provided with an emergency stopping device on the navigating bridge and independent from the bridge control system;
- d) propulsion machinery orders from the navigating bridge are to be indicated in the main machinery control station or at the manoeuvring platform as appropriate;
- e) remote control of the propulsion machinery is to be possible from only one station at a time; at one control station interconnected control units are permitted. There is to be at each station an indicator showing which station is in control of the propulsion machinery. The transfer of control between navigating bridge and machinery space

is to be possible only in the machinery space or machinery control room;

- f) it is to be possible to control the propulsion machinery locally, even in the case of failure in any part of the remote control system;
- g) the design of the remote control system is to be such that in case of its failure an alarm will be given and the present speed and direction of thrust be maintained until local control is in operation, unless the Society considers it impracticable;
- h) indicators are to be fitted on the navigating bridge for:
 - 1) propeller speed and direction in the case of fixed pitch propellers;
 - 2) propeller speed and pitch position in the case of controllable pitch propellers;
- i) an alarm is to be provided at the navigating bridge and in the machinery space to indicate low starting air pressure set at a level which still permits main engine starting operations. If the remote control system of the propulsion machinery is designed for automatic starting, the number of automatic consecutive attempts which fail to produce a start are to be limited to safeguard sufficient starting air pressure for starting locally.

2.4.3 (1/7/2015)

Where the main propulsion and associated machinery including sources of main electrical supply are provided with various degrees of automatic or remote control and are under continuous manned supervision from a control room, this control room is to be designed, equipped and installed so that the machinery operation will be as safe and effective as if it were under direct supervision; for this purpose Pt F, Ch 2, Sec 1 [3] and [4] apply as appropriate. Particular consideration is to be given to protection against fire and flooding,

2.5 Steering gear

2.5.1 Main and auxiliary steering gear (1/7/2015)

- a) Except as provided for in [2.5.2], units are to be provided with main steering gear and auxiliary steering gear to the satisfaction of the Society. The main steering gear and the auxiliary steering gear are to be so arranged that a single failure in one of them so far as is reasonable and practicable will not render the other one inoperative.
- b) The main steering gear is to be of adequate strength and sufficient to steer the unit at maximum service speed and this is to be demonstrated. The main steering gear and rudder stock are to be so designed they will not be damaged at maximum astern speed but this design requirement does not need to be proved by trials at maximum astern speed and maximum rudder angle.
- c) The main steering gear is to be, with the unit at its deepest seagoing draught, capable of putting the rudder over from 35° on one side to 35° on the other side with the unit running ahead at maximum service speed. The rudder is to be capable of being put over from 35° on either

side to 30° on the other side in not more than 28 seconds, under the same conditions

- d) The main steering gear is to be operated by power where necessary to fulfil the requirements of c) and in any case in which the Society requires a rudder stock of over 120 mm diameter in way of the tiller.
- e) The main steering gear power unit or units are to be arranged to start automatically when power is restored after a power failure.
- f) The auxiliary steering gear is to be of adequate strength and sufficient to steer the unit at navigable speed and capable of being brought speedily into action in an emergency.
- g) The auxiliary steering gear is to be capable of putting the rudder over from 15° on one side to 15° on the other side in not more than 60 seconds with the unit at its deepest seagoing draught while running at one half of its maximum speed ahead or seven knots, whichever is the greater,
- h) The auxiliary steering gear is to be operated by power where necessary to fulfil the requirements of g), and in any case in which the Society requires a rudder stock of over 230 mm diameter in way of the tiller.
- i) Where the main steering gear comprises two or more identical power units auxiliary steering gear need not be fitted if the main steering gear is capable of operating the rudder as required by c) while operating with all power units. As far as is reasonable and practicable the main steering gear is to be so arranged that a single failure in its piping or in one of the power unit will not impair the integrity of the remaining part of the steering gear.
- j) Control of the main steering gear is to be provided both on the navigating bridge and in the steering gear compartment, If the steering gear control system which provides for control from the navigating bridge is electric, it is to be supplied from the steering gear power circuit from a point within the steering gear compartment.

When the main steering gear is arranged according to i) two independent control systems are to be provided, each of which can be operated from the navigating bridge. Where the control system comprises a hydraulic telemotor, the Society may waive the requirements for a second independent control system.

Where the auxiliary steering gear is power operated, it is to be provided with a control system operated from the navigating bridge and this is to be independent of the control system for the main steering gear.

Means are to be provided in the steering gear compartment to disconnect the steering gear control system from the power circuit.

- k) A means of communication is to be provided between the navigating bridge and the steering gear compartment.
- l) The exact angular position of the rudder, if power operated, is to be indicated on the navigating bridge. The

rudder angle indication is to be independent of the steering gear control system.

The angular position of the rudder is to be recognizable in the steering gear compartment.

- m) An alternative power supply, sufficient at least to supply a steering gear power unit which complies with the requirement of g) and also its associated control system and the rudder angle indicator, are to be provided, automatically, within 45 seconds, either from the emergency source of electrical power, or from another independent source of power located in the steering gear compartment. This independent source of power is to be used only for this purpose and is to have a capacity sufficient for at least 10 minutes of continuous operation.

2.5.2 Non-conventional rudder (1/7/2015)

Where a non-conventional rudder is installed, or where a unit is steered by means other than a rudder, the Society is to give special consideration to the steering system so as to ensure that an acceptable degree of reliability and effectiveness, which is based on [2.5.1] a), is provided.

2.6 Electric and electrohydraulic steering gear

2.6.1 (1/7/2015)

Indicators for running indication of the motors of electric and electrohydraulic steering gear are to be installed on the navigating bridge and at a suitable machinery control position.

2.6.2 (1/7/2015)

- a) Each electric or electrohydraulic steering gear comprising one or more power units are to be served by at least two circuits fed from the main switchboard.

One of the circuits may pass through the emergency switchboard. Auxiliary electric or electrohydraulic steering gear associated with main electric or electrohydraulic steering gear may be connected to one of the circuits

supplying this main steering gear. The circuits supplying electric or electrohydraulic steering gear are to have adequate rating for supplying all motors which can be simultaneously connected to it and have to operate simultaneously,

- b) Short-circuit protection and an overload alarm are to be provided for these circuits and motors. Protection against excess current, if provided, is to be for not less than twice the full load current of the motor or circuit so protected, and is to be arranged to permit the passage of the appropriate starting currents. Where a three-phase supply is used, an alarm is to be provided that will indicate failure of any one of the supply phases. The alarms required in the subpara-graph are to be both audible and visual and be situated in a position on the navigating bridge where they can be readily observed.

2.7 Communication between the navigating bridge and the engine-room

2.7.1 (1/7/2015)

Units are to be provided with at least two independent means for communicating orders from the navigating bridge to the position in the machinery space or control room from which the engines are normally controlled. One of these is to be an engine-room telegraph providing visual indication of the orders and responses both in the engine-room and on the navigating bridge. Consideration is to be given to providing a means of communication to any other positions from which the engines may be controlled.

2.8 Engineer's alarm

2.8.1 (1/7/2015)

An engineer's alarm is to be provided to be operated from the engine control room or at the manoeuvring platform, as appropriate, and clearly audible in the engineer's accommodation.

SECTION 5

ELECTRICAL INSTALLATIONS

1 General

1.1 Application

1.1.1 (1/7/2015)

The requirements in this Section apply to FPU in addition to (and when indicated in replacement of) those contained in Part C, Chapter 2.

1.2 Documentation to be submitted

1.2.1 (1/7/2015)

In addition to the documents requested in Pt C, Ch 2, Sec 1, Tab 1 of the Rules for the Classification of Ships the following are to be submitted for approval:

- a) plan of hazardous areas
- b) document giving details of types of cables and safety characteristics of the equipment installed in hazardous areas.

1.3 Power sources location

1.3.1 (1/7/2015)

Sources of electrical power and their section boards and distribution boards, etc., are normally not to be located in hazardous locations.

1.3.2 (1/7/2015)

The generating plant, switchboards and batteries are to be separated from any zone 0 by cofferdams or equivalent spaces and from other hazardous areas by gas-tight steel divisions.

1.3.3 (1/7/2015)

Access between such spaces has to comply with [5.3.8].

2 Main plant

2.1 Shaft generators

2.1.1 (1/7/2015)

The arrangement of the unit's main source of power is to be such that essential services can be maintained regardless of the speed and direction of the main propelling engines or shafting.

2.1.2 (1/7/2015)

The generating plant is to be such as to ensure that with any one generator or its primary source of power out of operation, the remaining generator or generators will be capable of providing the electrical services necessary to start the main propulsion plant from a dead ship condition. The emergency generator may be used for the purpose of starting from a dead ship condition if its capability either alone or combined with that of any generator is sufficient to provide at the same time those services required by [4.2.8].

2.2 Requirement for self propelled units

2.2.1 (1/7/2015)

For electrically self-propelled units the application of Pt C, Ch 2, Sec 2, [3.2.5] need only include for propulsion sufficient power to ensure safe navigation when under way.

2.2.2 (1/7/2015)

The main switchboard is to be so placed relative to one main generating station that, as far as is practicable the integrity of the normal supply may be affected only by a fire or other casualty in one space. An environmental enclosure for the main switchboard, such as may be provided by a machinery control room situated within the main boundaries of the space, is not to be considered as separating the switchboards from the generators.

2.2.3 (1/7/2015)

Where the main source of electrical power is necessary for propulsion and steering of the unit, the system is to be so arranged that the electrical supply to equipment necessary for propulsion and steering and to ensure safety of the unit will be maintained or immediately restored in the case of loss of any one of the generators in service.

2.2.4 (1/7/2015)

Where the main source of electrical power is necessary for propulsion of the ship, the main busbar is to be subdivided into at least two parts which are normally to be connected by circuit breakers or other approved means; so far as is practicable, the connection of generating sets and other duplicated equipment is to be equally divided between the parts.

2.2.5 (1/7/2015)

Electrically operated speed control systems of main engines are to be fed from the main source of electrical power.

2.2.6 (1/7/2015)

Where more than one main propulsion engine is foreseen, each speed control system is to be provided with an individual supply by means of separate wiring from the main switchboard or from two independent section boards. Being the main bus-bars divided into at least two sections, the governors are, as far as practicable, to be supplied equally from the two sections.

2.2.7 (1/7/2015)

In the case of propulsion engines which do not depend for their operation on electrical power, i.e. pumps driven from the main engine, the speed control systems are to be fed both from the main source of electrical power and from an accumulator battery for at least 15 minutes or from a similar supply source.

Such battery may also be used for other services such as automation systems, where foreseen.

2.2.8 (1/7/2015)

Steering gear circuits are to be provided with short-circuit protection only.

2.2.9 (1/7/2015)

In case of electrical propulsion plants see Sec 6.

3 Shore connection

3.1 Shore supply

3.1.1 (1/7/2015)

Where arrangements are made for supplying the electrical installation from a source on shore or elsewhere, a suitable connection box is to be installed on the unit in a convenient location to receive the flexible cable from the external source.

3.1.2 (1/7/2015)

Permanently fixed cables of adequate rating are to be provided for connecting the box to the main switchboard or emergency switchboard.

3.1.3 (1/7/2015)

Where necessary for systems with earthed neutrals, the box is to be provided with an earthed terminal for connection between the shore's and unit's neutrals or for connection of a protective conductor.

3.1.4 (1/7/2015)

The connection box is to contain a circuit-breaker or a switch-disconnector and fuses.

The shore connection is to be protected against short-circuit and overload; however, the overload protection may be omitted in the connection box if provided on the main or emergency switchboard.

3.1.5 (1/7/2015)

Means are to be provided for checking the phase sequence of the incoming supply in relation to the unit's system.

3.1.6 (1/7/2015)

The cable connection to the box is to be provided with at least one switch-disconnector on the main or emergency switchboard.

3.1.7 (1/7/2015)

The shore connection is to be provided with an indicator at the main or emergency switchboard in order to show when the cable is energized.

3.1.8 (1/7/2015)

At the connection box a notice is to be provided giving full information on the nominal voltage and frequency of the installation.

3.1.9 (1/7/2015)

The switch-disconnector on the main or emergency switchboard is to be interlocked with the generator circuit-breakers in order to prevent its closure when any generator is supplying the main or emergency switchboard unless special provisions to the satisfaction of the Society are taken to permit safe transfer of electrical load.

3.1.10 (1/7/2015)

Adequate means are to be provided to equalize the potential between the hull and the shore when the electrical installation of the unit is supplied from shore..

3.1.11 (1/7/2015)

Provisions are to be made for securing the trailing cables to the framework so that mechanical stress is not applied to the electrical terminals.

3.1.12 (1/7/2015)

Any transformer used for shore-connection is to be of the double-wound type.

3.1.13 (1/7/2015)

The maximum short-circuit rating of the distribution system is to be higher than the short-circuit level of the shore supply system.

3.1.14 (1/7/2015)

Permanently fixed cables connecting the shore connection box to the main or emergency switchboard are to be protected by fuses or circuit-breakers.

4 Emergency plant

4.1 Application

4.1.1 (1/7/2015)

The requirements of Pt C, Ch 2, Sec 2, [3.3], [4.4] and [5] are replaced by those of [4.2].

4.2 Emergency source of electric power

4.2.1 (1/7/2015)

Every unit should be provided with a self-contained emergency source of electrical power.

4.2.2 (1/7/2015)

Every unit should be provided with a self-contained emergency source of electrical power.

4.2.3 (1/7/2015)

The location of the emergency source of power, any associated transforming equipment, the transitional source of emergency power and emergency switchboard in relation to the main source of electrical power is to be such as to ensure to the satisfaction of the Society that a fire or other casualty in the space containing the main source of electrical power or in any machinery space of Category A will not interfere with the supply or distribution of emergency power.

4.2.4 (1/7/2015)

The emergency source of electrical power, any associated transforming equipment, the transitional source of emergency power and the emergency switchboard are not to be located in any space or spaces containing the main source of electrical power or other equipment presenting a fire risk nor in any room or compartment having direct access to such space or spaces.

4.2.5 (1/7/2015)

As far as practical, the space containing the emergency source of power, any associated transforming equipment, the transitional source of emergency power and the emergency switchboard is not to be contiguous to boundaries of machinery spaces of Category A or of those spaces containing the main source of electrical power. Where the emergency source of power, any associated transforming equipment, the transitional source of emergency power, and the emergency switchboard are contiguous to the boundaries of machinery spaces of Category A or to those spaces containing the main source of electrical power, or to spaces of Zone 1 or Zone 2, the contiguous boundaries is to be in compliance with Pt C, Ch 4, Sec 2, [3].

4.2.6 (1/7/2015)

Provided that suitable measures are taken for safeguarding independent emergency operation under all circumstances, the emergency switchboard may be used to supply non-emergency circuits, and the emergency generator may be

used exceptionally and for short periods to supply non-emergency circuits.

4.2.7 (1/7/2015)

For units where the main source of electrical power is located in two or more spaces which have their own systems, including power distribution and control systems completely independent of the systems in the other spaces and such that a fire or other casualty in any one of the spaces will not affect the power distribution from the others, or to the services required by [4.2.8], the requirements of [4.2.1] may be considered satisfied without an additional emergency source of electrical power, provided that the Society is satisfied that:

- a) there are at least two generating sets, meeting the requirements of [4.2.18] and each of sufficient capacity to meet the requirements of [4.2.8], in each of at least two spaces;
- b) the arrangements required by 4.2.7 (a) in each such space are equivalent to those required by [4.2.10] so that a source of electrical power is available at all times to the services required by [4.2.8];
- c) the location of each of the spaces referred to in [4.2.7] a), is in compliance with [4.2.2], and the boundaries meet the requirements of [4.2.3], [4.2.4] and [4.2.5], except that contiguous boundaries have to consist of an "A-60" bulkhead and a cofferdam, or a steel bulkhead insulated to class "A-60" on both sides.

4.2.8 (1/7/2015)

The power available is to be sufficient to supply all those services that are essential for safety in an emergency, due regard being paid to such services as may have to be operated simultaneously.

The emergency source of power is to be capable, having regard to starting currents and the transitory nature of certain loads, of supplying simultaneously at least the following services for the periods specified hereinafter, if they depend upon an electrical source for their operation.

- a) For a period of 18 hours, emergency lighting:
 - at every embarkation station on deck and over sides;
 - in all service and accommodation alleyways, stairways and exits, personnel lift cars, and personnel lift trunks;
 - in the machinery spaces and main generating stations including their control positions;
 - in all control stations and in all machinery control rooms;
 - in all spaces from which control of the production-process is performed and where controls of machinery essential for the performance of this process, or devices for emergency switching-off of the power plant are located;
 - at the stowage position or positions for firemen's outfits;
 - at the sprinkler pump, if any, at the fire pump referred to in e), at the emergency bilge pump, if any, and at their starting positions;
 - on helicopter landing decks;
 - at the steering gear.

- b) For a period of 18 hours:
 - the navigation lights,
 - other lights and sound signals, required by the International Regulations for the Prevention of Collisions at Sea, in force.
- c) For a period of 4 days:
 - any signalling lights, or
 - sound signals
 which may be required for marking of offshore structures.
- d) For a period of 18 hours:
 - all internal communication equipment that is required in an emergency;
 - fire and gas detection and their alarm systems;
 - intermittent operation of the manual fire alarms and all internal signals that are required in an emergency; and
 - the capability of closing the blow-out preventer and of disconnecting the unit from the well head arrangement, if electrically controlled;
 unless they have an independent supply from an accumulator battery suitably located for use in an emergency and sufficient for the period of 18 hours.
- e) For a period of 18 hours:
 - one of the fire pumps, if dependent upon the emergency generator for its source of power;
 - permanently installed diving equipment, if dependent upon the unit's electrical power;
 - radio communication installations;
 - equipment, operating on electric power, serving embarkation stations of survival craft for abandoning the unit.
- f) On column-stabilized units, for a period of 18 hours:
 - ballast control and indicating systems required by Sec 4, [1.5.5]; and
 - the largest of the ballast pumps required by Sec 4, [1.5.5]; only one of the connected pumps need be considered to be in operation at any time.
- g) For a period of half an hour:
 - power to operate the watertight doors as provided by Sec 3, [8.2.1]; but not necessarily all of them simultaneously, unless an independent temporary source of stored energy is provided;
 - power to operate the controls and indicators required by Sec 3, [8.2.1].
- h) For a period of 18 hours:
 - navigational aids as required by SOLAS Convention;
 - intermittent operation of the daylight signalling lamp and the unit's whistle;
 unless they have an independent supply from an accumulator battery suitably located for use in an emergency and sufficient for the period of 18 hours.
- i) For a period of 10 minutes:
 - the steering gear where it is required to be so supplied by Sec 4, [2.5.1].

4.2.9 (1/7/2015)

The emergency source of power may be either a generator or an accumulator battery.

4.2.10 (1/7/2015)

Where the emergency source of power is a generator it is to be:

- a) driven by a suitable prime mover with an independent supply of fuel, having a flashpoint of not less than 43°C;
- b) started automatically upon failure of the normal electrical supply unless a transitional source of emergency power in accordance with following item c) is provided; where the emergency generator is automatically started, it should be automatically connected to the emergency switchboard; those services referred to in [4.2.12] are then to be connected automatically to the emergency generator; and unless a second independent means of starting the emergency generator is provided, the single source of stored energy is to be protected to preclude its complete depletion by the automatic starting system; and
- c) provided with a transitional source of emergency power, as specified in [4.2.12], unless the emergency generator is capable of supplying the services mentioned in [4.2.12] and of being automatically started and supplying the required load as quickly as is safe and practicable but in not more than 45 seconds.

4.2.11 (1/7/2015)

Where the emergency source of power is an accumulator battery it is to be capable of:

- a) carrying the emergency load without recharging while maintaining the voltage of the battery throughout the discharge period within plus or minus 12% of its nominal voltage;
- b) automatically connecting to the emergency switchboard in the event of failure of the main power supply; and
- c) immediately supplying at least those services specified in [4.2.12].

4.2.12 (1/7/2015)

The transitional source or sources of emergency power, where required by [4.2.10] c), is to consist of an accumulator battery suitably located for use in an emergency, which has to operate without recharging whilst maintaining the voltage of the battery throughout the discharge period within plus or minus 12% of its nominal voltage, and be of sufficient capacity and so arranged as to supply automatically, in the event of failure of either the main or the emergency source of power, the following services for half an hour at least if they depend upon an electrical source for their operation:

- a) the lighting required by [4.2.8] a) and b). For this transitional phase, the required emergency lighting, in respect of the machinery space and accommodation and service areas, may be provided by permanently fixed, indi-

vidual accumulator lamps which are automatically charged and operated;

- b) all essential internal communication equipment required by the first two items of [4.2.8] d); and
- c) intermittent operation of the services referred to in last two items of [4.2.8] d),

unless in the case of preceding items b) and c) they have an independent supply from an accumulator battery suitably located for use in an emergency and sufficient for the period specified.

4.2.13 (1/7/2015)

The emergency switchboard is to be installed as near as is practicable to the emergency source of power and, where the emergency source of power is a generator, the emergency switchboard is preferably to be located in the same space.

4.2.14 (1/7/2015)

No accumulator battery fitted in accordance with this requirement for emergency or transitional power supply is to be installed in the same space as the emergency switchboard, unless appropriate measures to the satisfaction of the Society are taken to extract the gases discharged from the said batteries.

4.2.15 (1/7/2015)

An indicator is to be mounted in a suitable place on the main switchboard or in the machinery control room to indicate when the batteries constituting either the emergency source of power or the transitional source of power, referred to in [4.2.11] or [4.2.12] are being discharged.

4.2.16 (1/7/2015)

The emergency switchboard is to be supplied in normal operation from the main switchboard by an interconnector feeder which is to be adequately protected at the main switchboard against overload and short circuit. The arrangement at the emergency switchboard is to be such that the interconnector feeder is disconnected automatically at the emergency switchboard upon failure of the main power supply. Where the system is arranged for feedback operation, from emergency to main switchboard, the interconnector feeder is also to be protected at the emergency switchboard at least against short circuit.

4.2.17 (1/7/2015)

In order to ensure ready availability of emergency supplies, arrangements are to be made where necessary to disconnect non-emergency circuits automatically from the emergency switchboard to ensure that power is available automatically to the emergency circuits.

4.2.18 (1/7/2015)

The emergency generator and its prime mover and any emergency accumulator battery are to be designed to function at full rated power when upright and when inclined up to the maximum angle of heel in the intact and damaged condition, as determined in accordance with Sec 4. In no case need the equipment be designed to operate when inclined more than:

- a) 25° in any direction on a column-stabilized unit;
- b) 22,5° about the longitudinal axis and/or when inclined 10° about the transverse axis on a surface unit.

4.2.19 (1/7/2015)

Provision is to be made for the periodic testing of the complete emergency system. This should include the testing of automatic starting arrangements.

5 Electrical installations in hazardous location

5.1 Monitoring of circuits in hazardous areas

5.1.1 (1/7/2015)

The devices intended to continuously monitor the insulation level of all distribution systems are also to monitor all circuits, other than intrinsically safe circuits, connected to apparatus in hazardous areas or passing through such areas.

An audible and visual alarm is to be given, at a manned position, in the event of an abnormally low level of insulation.

Systems fed by single transformers supplying one consumer or a control circuit do not require an earth fault detection.

5.2 Precautions against inlet of hazardous areas

5.2.1 (1/7/2015)

Suitable arrangements are to be provided, to the satisfaction of the Society, so as to prevent the possibility of gases or vapours passing from a gas-dangerous space to another space through runs of cables or their conduits.

5.3 Hazardous location classification and permitted electrical equipment

5.3.1 (1/7/2015)

Units are to be assessed with regard to any potential explosive gas atmosphere in accordance with the provisions of [5.3] or alternatively with an acceptable Code or Standard giving equivalent safety.

5.3.2 (1/7/2015)

The results are to be documented in area classification drawings to allow the proper selection of all electrical components to be installed.

5.3.3 (1/7/2015)

The hazardous location classification is to be carried out by those who have knowledge of the properties of flammable materials, the process and the equipment, in consultation with, as appropriate, safety, electrical, mechanical and other engineering personnel.

5.3.4 (1/7/2015)

Classification of hazardous areas in ZONES is defined in Pt C, Ch 2, Sec 1 [3.24] of the Rules for the Classification of Ships.

5.3.5 (1/7/2015)

Release as a result of accidental events such as blow-out or vessel rupture is not addressed by area classification. It is to be covered by emergency measures.

5.3.6 (1/7/2015)

Openings, penetrations or connections between areas of different hazardous area classification are to be avoided, e.g. through ventilation systems, air pipes or drain systems.

5.3.7 (1/7/2015)

Enclosed or semi-enclosed spaces (not containing a source of hazard) having a direct opening, including those for ventilation, into any hazardous area are to be designated as the

same hazardous zone as the area in which the opening is located. See also [5.3.6] and [5.3.9]. Electrical installations are to comply with the requirements for the space or area into which the opening leads.

5.3.8 (1/7/2015)

Except for operational reasons, access doors or other openings are not to be provided between a non-hazardous space and a hazardous area or between a zone 2 space and a zone 1 space. Where such access doors or other openings are provided, any non-hazardous enclosed space having a direct access to any zone 1 location or zone 2 location becomes the same zone as the location except that:

- a) an enclosed space with direct access to any zone 1 location can be considered as zone 2 if:
 - the access is fitted with a gastight door opening into the zone 2 space, and
 - ventilation is such that the air flow with the door open is from the zone 2 space into the zone 1 location, and
 - loss of ventilation is alarmed at a manned station;
- b) an enclosed space with direct access to any zone 2 location is not considered hazardous if:
 - the access is fitted with a self-closing gastight door that opens into the non-hazardous location, and
 - ventilation is such that the air flow with the door open is from the non-hazardous space into the zone 2 location, and
 - loss of ventilation is alarmed at a manned station;
- c) an enclosed space with direct access to any zone 1 location is not considered hazardous if:
 - the access is fitted with self-closing gastight doors forming an airlock, and
 - the space has ventilation overpressure in relation to the hazardous space, and
 - loss of ventilation overpressure is alarmed at a manned station.

Where ventilation arrangements for the intended safe space are considered sufficient by the Society to prevent any ingress of gas from the zone 1 location, the two self-closing doors forming an airlock may be replaced by a single self-closing gastight door which opens into the non-hazardous location and has no hold-back device.

5.3.9 (1/7/2015)

Piping systems are to be designed to preclude direct communication between hazardous areas of different classifications and between hazardous and non-hazardous areas.

5.4 Ventilation

5.4.1 (1/7/2015)

For requirements of ventilation systems in hazardous areas, see Pt C, Ch 4, Sec 2, [3.5].

5.5 Protection in overpressure

5.5.1 (1/7/2015)

For requirements relevant to protection in overpressure, see Pt C, Ch 4, Sec 2, [3.6].

5.6 Process plant location classification and permitted electrical equipment

5.6.1 (1/7/2015)

Hazardous location classification is to be carried out in accordance with the following requirement and IEC 60079-10, or, alternatively, with an acceptable Code or Standard giving equivalent safety.

5.6.2 (1/7/2015)

It is to be taken into consideration that the horizontal extent of the hazardous areas at ground level will increase with increasing relative density of the gas or vapour which may be released and the vertical extent above the source will increase with decreasing the gas or vapour relative density.

5.6.3 (1/7/2015)

Zone 0 hazardous location normally include areas or spaces:

- a) within process apparatus developing flammable gas or vapours;
- b) around vent pipes which discharges continually or for long periods;
- c) over/near surface of flammable liquids in general;

5.6.4 (1/7/2015)

Zone 1 hazardous location normally include areas or spaces:

- a) with a certain radius around the outlet of vent pipes, pipelines and safety valves;
- b) around ventilation openings from a zone 1 area;
- c) around flexible pipelines and hoses;
- d) around sample taking points (valves etc.);
- e) around seals of pumps, compressor, and similar apparatus, if primary source of release and rooms without ventilation, with direct access from a zone 2 area; and rooms or parts of rooms containing secondary sources of release, where internal outlet indicate zone 2, but where efficient dilution of an explosive atmosphere cannot be expected because of lack of ventilation.

5.6.5 (1/7/2015)

Zone 2 hazardous location normally include areas or spaces:

- a) Around flanges, connections, valves, etc.;
- b) Outside of zone 1, around the outlet of vent pipes, pipelines and safety valves;
- c) Around vent openings from the zone 2 area;
- d) Between the main deck and the production/facilities deck, unless installations on the deck result in a zone 1 area classification.

5.6.6 (1/7/2015)

The following provisions are to be taken into account:

- a) Pipelines without flanges, connections, valves or other similar fittings need not be regarded as source of release.
- b) Certain areas and spaces (rooms) are, if so indicated by the circumstances, to be classified as more hazardous zone than set out in these examples.
- c) Certain areas and spaces (rooms) may, under certain circumstances and/or when special precautions are taken,

be classified as a less hazardous zone than indicated by these examples. Such special circumstances may be, for example, shielding or reinforced ventilation arrangements.

- d) Enclosed rooms, without ventilation, with openings to an area with explosion risks, are to be classified as the same, or as a more hazardous zone than such an area.

5.6.7 (1/7/2015)

Electrical installations are to be such as to minimize the risk of fire and explosion from flammable products.

5.6.8 (1/7/2015)

Electrical equipment and cables installed in hazardous areas are to be limited to those necessary for operational purposes.

5.6.9 (1/7/2015)

Where electrical equipment is installed in gas-dangerous spaces or zones and is essential for operational purposes, it should be of a safe type for operation in the flammable atmosphere concerned.

5.6.10 (1/7/2015)

Portable electrical equipment, supplied by cables is not permitted in hazardous areas, unless special precautions are taken (see IEC 61892-7 clause 6.5).

5.6.11 (1/7/2015)

For electrical cables see Pt C, Ch 2, Sec 2, [12.2].

5.6.12 (1/7/2015)

Permitted electrical equipment are indicated in Pt C, Ch 2, Sec 2, [12.1.3], [12.1.4], [12.1.5] and [12.1.6] as applicable.

5.6.13 (1/7/2015)

The cross-section of cables installed in hazardous areas is to be correlated to the characteristics time/current of the relevant electrical protective device in order to limit the surface temperature of the cable to a safety value obliged by the temperature class of the dangerous gas likely to be present in the area, under the most severe expected fault condition.

5.6.14 (1/7/2015)

Permitted certified safe type electrical equipment is to be chosen taking into account the more demanding of the required explosion groups and temperature classes of the products which may cause the presence of an explosive atmosphere in consequence handling, processing and storing (if any) operations.

5.6.15 (1/7/2015)

For increased safety motors, due consideration is to be given to the protection against overcurrent, locked rotor, extended starting periods, etc., which could cause excessive temperatures.

5.6.16 (1/7/2015)

Electrical apparatus and cables are, where practicable, to be excluded from any compartment in which explosive are stored. Where lighting is required, the light has to come from outside, through the boundaries of the compartment. If electrical equipment cannot be excluded from such a compartment it is to be so designed and used as to minimize the risk of fire or explosion.

SECTION 6

ELECTRIC PROPULSION PLANT

1 General

1.1 Applicable requirements

1.1.1 (1/7/2015)

The following requirements apply to units for which the main propulsion plants are provided by at least one electric propulsion motor and its electrical supply. All electrical components of the propulsion plants are to comply with these requirements.

1.1.2 (1/7/2015)

Prime movers are to comply with the requirements of Sec 4, [2.1.2].

1.1.3 (1/7/2015)

For the torsional vibration characteristics of the electric propulsion plant, the provisions of Sec 4, [2.1.2] apply.

1.1.4 (1/7/2015)

Cooling and lubricating oil systems are to comply with the requirements of Pt C, Ch 1, Sec 10 of the Rules for the Classification of Ships.

1.1.5 (1/7/2015)

Monitoring and control systems are to comply with the requirements of Part C, Chapter 3.

1.1.6 (1/7/2015)

Installations assigned an additional notation for automation are to comply with the requirements of Part F.

1.2 Operating conditions

1.2.1 (1/7/2015)

The normal torque available on the electric propulsion motors for manoeuvring is to be such as to enable the vessel to be stopped or reversed when sailing at its maximum service speed.

1.2.2 (1/7/2015)

Adequate torque margin is to be provided for three-phase synchronous motors to avoid the motor pulling out of synchronism during rough weather and when turning.

1.2.3 (1/7/2015)

When an electric generating plant has a continuous rating greater than the electric propulsion motor rating, means are to be provided to limit the continuous input to the motor. This value is not to exceed the continuous full load torque for which motor and shafts are designed.

1.2.4 (1/7/2015)

The plant as a whole is to have sufficient overload capacity to provide the torque, power and reactive power needed during starting and manoeuvring conditions.

Locked rotor torque which may be required in relation to the operation of the vessel (e.g. for navigation in ice) is to be considered.

1.2.5 (1/7/2015)

The electric motors and shaftline are to be constructed and installed so that, at any speed reached in service, all the moving components are suitably balanced.

2 Design of the propulsion plant

2.1 General

2.1.1 (1/7/2015)

The electrical power for the propulsion system may be supplied from generating sets, dedicated to the propulsion system, or from a central power generation plant, which supplies the unit's services and electric propulsion.

The minimum configuration of an electric propulsion plant consists of one prime mover, one generator and one electric motor. When the electrical production used for propulsion is independent of the shipboard production, the diesel engines driving the electric generators are to be considered as main engines.

2.1.2 (1/7/2015)

For plants having only one propulsion motor controlled via a static convertor, a standby convertor which it is easy to switch over to is to be provided. Double stator windings with one convertor for each winding are considered as an alternative solution.

2.1.3 (1/7/2015)

In electric propulsion plants having two or more constant voltage propulsion generating sets, the electrical power for the unit's auxiliary services may be derived from this source. Additional unit's generators for auxiliary services need not be fitted provided that effective propulsion and the services mentioned in Pt C, Ch 2, Sec 2, [3.2.5] are maintained with any one generating set out of service.

2.1.4 (1/7/2015)

Plants having two or more propulsion generators, two or more static convertors or two or more motors on one propeller shaft are to be so arranged that any device may be taken out of service and disconnected electrically, without affecting the operation of the others.

2.2 Power supply

2.2.1 (1/7/2015)

Where the plant is intended exclusively for electric propulsion, voltage variations and maximum voltage are to be maintained within the limits required in Pt C, Ch 2, Sec 2 of the Rules for the Classification of Ships.

2.2.2 (1/7/2015)

In special conditions (e.g. during crash-stop manoeuvres), frequency variations may exceed the limits stipulated in Pt C, Ch 2, Sec 2 of the Rules for the Classification of Ships.

provided that other equipment operating on the same network is not unduly affected.

2.2.3 (1/7/2015)

The electric plant is to be so designed as to prevent the harmful effects of electromagnetic interference generated by semiconductor convertors, in accordance with Pt C, Ch 2, Sec 2 of the Rules for the Classification of Ships.

2.3 Auxiliary machinery

2.3.1 (1/7/2015)

Propeller/thruster auxiliary plants are to be supplied directly from the main switchboard or from the main distribution board or from a distribution board reserved for such circuits, at the auxiliary rated voltage.

2.3.2 (1/7/2015)

When the installation has one or more lubrication systems, devices are to be provided to ensure the monitoring of the lubricating oil return temperature.

2.3.3 (1/7/2015)

Propelling machinery installations with a forced lubrication system are to be provided with alarm devices which will operate in the event of oil pressure loss.

2.4 Electrical protection

2.4.1 (1/7/2015)

Automatic disconnections of electric propulsion plants which adversely affect the manoeuvrability of the unit are to be restricted to faults liable to cause severe damage to the equipment.

2.4.2 (1/7/2015)

The following protection of convertors is to be provided:

- protection against overvoltage in the supply systems to which convertors are connected
- protection against overcurrents in semiconductor elements during normal operation
- short-circuit protection

2.4.3 (1/7/2015)

Overcurrent protective devices in the main circuits are to be set sufficiently high so that there is no possibility of activation due to the overcurrents caused in the course of normal operation, e.g. during manoeuvring or in heavy seas.

2.4.4 (1/7/2015)

Overcurrent protection may be replaced by automatic control systems ensuring that overcurrents do not reach values which may endanger the plant, e.g. by selective tripping or rapid reduction of the magnetic fluxes of the generators and motors.

2.4.5 (1/7/2015)

In the case of propulsion plants supplied by generators in parallel, suitable controls are to ensure that, if one or more generators are disconnected, those remaining are not overloaded by the propulsion motors.

2.4.6 (1/7/2015)

In three-phase systems, phase-balance protective devices are to be provided for the motor circuit which de-excite the generators and motors or disconnect the circuit concerned.

2.5 Excitation of electric propulsion motor

2.5.1 (1/7/2015)

Each propulsion motor is to have its own exciter.

2.5.2 (1/7/2015)

For plants where only one generator or only one motor is foreseen, each machine is to be provided with a standby static electronic exciter, which it is easy to switch over to.

2.5.3 (1/7/2015)

In the case of multi-propeller propulsion units, one standby static electronic exciter which it is easy to switch over to is to be provided.

2.5.4 (1/7/2015)

For the protection of field windings and cables, means are to be provided for limiting the induced voltage when the field circuits are opened. Alternatively, the induced voltage when the field circuits are opened is to be maintained at the nominal design voltage.

2.5.5 (1/7/2015)

In excitation circuits, there is to be no overload protection causing the opening of the circuit, except for excitation circuits with semiconductor convertors.

3 Construction of rotating machines and semiconductor convertors

3.1 Ventilation

3.1.1 (1/7/2015)

Where electrical machines are fitted with an integrated fan and are to be operated at speeds below the rated speed with full load torque, full load current, full load excitation or the like, the design temperature rise is not to be exceeded.

3.1.2 (1/7/2015)

Where electrical machines or convertors are force-ventilated, at least two fans, or other suitable arrangements, are to be provided so that limited operation is possible in the event of one fan failing.

3.2 Protection against moisture and condensate

3.2.1 (1/7/2015)

Machines and equipment which may be subject to the accumulation of moisture and condensate are to be provided with effective means of heating. The latter is to be provided for motors above 500 kW, in order to maintain the temperature inside the machine at about 3°C above the ambient temperature.

3.2.2 (1/7/2015)

Provision is to be made to prevent the accumulation of bilge water, which is likely to enter inside the machine.

3.3 Rotating machines

3.3.1 (1/7/2015)

Electrical machines are to be able to withstand the excess speed which may occur during operation of the unit.

3.3.2 (1/7/2015)

The design of rotating machines supplied by static converters is to consider the effects of harmonics.

3.3.3 (1/7/2015)

The winding insulation of electrical machines is to be capable of withstanding the overvoltage which may occur in manoeuvring conditions.

3.3.4 (1/7/2015)

The design of a.c. machines is to be such that they can withstand without damage a sudden short-circuit at their terminals under rated operating conditions.

3.3.5 (1/7/2015)

The obtainable current and voltage of exciters and their supply are to be suitable for the output required during manoeuvring and overcurrent conditions, including short-circuit in the transient period.

3.4 Semiconductor convertors**3.4.1 (1/7/2015)**

The following limiting repetitive peak voltages U_{RM} are to be used as a base for each semiconductor valve:

- when connected to a supply specifically for propeller drives:

$$U_{RM} = 1,5 \cdot U_P$$

- when connected to a common main supply:
- when connected to a supply specifically for propeller drives:

$$U_{RM} = 1,8 \cdot U_P$$

where:

U_P : is the peak value of the rated voltage at the input of the semiconductor convertor..

3.4.2 (1/7/2015)

For semiconductor convertor elements connected in series, the values in [3.4.1] are to be increased by 10%. Equal voltage distribution is to be ensured.

3.4.3 (1/7/2015)

For parallel-connected convertor elements, an equal current distribution is to be ensured.

3.4.4 (1/7/2015)

Means are to be provided, where necessary, to limit the effects of the rate of harmonics to the system and to other semiconductor convertors. Suitable filters are to be installed to keep the current and voltage within the limits given in Pt C, Ch 2, Sec 2 of the Rules for the Classification of Ships.

4 Control and monitoring**4.1 General****4.1.1 (1/7/2015)**

The control and monitoring systems, including programmable electronic systems, are to be type approved, according to Pt C, Ch 3, Sec 6 of the Rules for the Classification of Ships.

4.2 Power plant control systems**4.2.1 (1/7/2015)**

The power plant control systems are to ensure that adequate propulsion power is available, by means of automatic control systems and/or manual remote control systems.

4.2.2 (1/7/2015)

The automatic control systems are to be such that, in the event of a fault, the propeller speed and direction of thrust do not undergo substantial variations.

4.2.3 (1/7/2015)

Failure of the power plant control system is not to cause complete loss of generated power (i.e. blackout) or loss of propulsion.

4.2.4 (1/7/2015)

The loss of power plant control systems is not to cause variations in the available power; i.e. starting or stopping of generating sets is not to occur as a result.

4.2.5 (1/7/2015)

The loss of power plant control systems is not to cause variations in the available power; i.e. starting or stopping of generating sets is not to occur as a result.

4.2.6 (1/7/2015)

The control system is to include the following main functions:

- monitoring of the alarms: any event critical for the proper operation of an essential auxiliary or a main element of the installation requiring immediate action to avoid a breakdown is to activate an alarm
- speed or pitch control of the propeller
- shutdown or slow down when necessary.

4.2.7 (1/7/2015)

Where the electric propulsion system is supplied by the main switchboard together with the unit's services, load shedding of the non-essential services and /or power limitation of the electric propulsion is to be provided. An alarm is to be triggered in the event of power limitation or load shedding.

4.2.8 (1/7/2015)

The risk of blackout due to electric propulsion operation is to be eliminated. At the request of the Society, a failure mode and effects analysis is to be carried out to demonstrate the reliability of the system.

4.3 Indicating instruments**4.3.1 (1/7/2015)**

In addition to the provisions of Part C, Chapter 3, instruments indicating consumed power and power available for propulsion are to be provided at each propulsion remote control position.

4.3.2 (1/7/2015)

The instruments specified in [4.3.3] and [4.3.4] in relation to the type of plant are to be provided on the power control board or in another appropriate position.

4.3.3 (1/7/2015)

The following instruments are required for each propulsion alternator:

- an ammeter on each phase, or with a selector switch to all phases
- a voltmeter with a selector switch to all phases
- a wattmeter
- a tachometer or frequency meter
- a power factor meter or a var-meter or a field ammeter for each alternator operating in parallel
- a temperature indicator for direct reading of the temperature of the stator windings, for each alternator rated above 500 kW.

4.3.4 (1/7/2015)

The following instruments are required for each a.c. propulsion motor:

- an ammeter on the main circuit
- an embedded sensor for direct reading of the temperature of the stator windings, for motors rated above 500 kW
- an ammeter on the excitation circuit for each synchronous motor
- a voltmeter for the measurement of the voltage between phases of each motor supplied through a semiconductor frequency convertor.

4.3.5 (1/7/2015)

Where a speed measuring system is used for control and indication, the system is to be duplicated with separate sensor circuits and separate power supply.

4.3.6 (1/7/2015)

An ammeter is to be provided on the supply circuit for each propulsion semiconductor bridge.

4.4 Alarm systems

4.4.1 (1/7/2015)

An alarm system is to be provided, in accordance with the requirements of Part C, Chapter 3. The system is to give an indication at the control positions when the parameters specified in [4.4] assume abnormal values or any event occurs which can affect the electric propulsion.

4.4.2 (1/7/2015)

Where an alarm system is provided for other essential equipment or installations, the alarms in [4.4.1] may be connected to such system.

4.4.3 (1/7/2015)

Critical alarms for propulsion may be grouped, but are to be indicated to the bridge separately from other alarms.

4.4.4 (1/7/2015)

The following alarms are to be provided, where applicable:

- high temperature of the cooling air of machines and semiconductor convertors provided with forced ventilation (see Note 1)
- reduced flow of primary and secondary coolants of machines and semiconductor convertors having a closed cooling system with a heat exchanger
- leakage of coolant inside the enclosure of machines and semiconductor convertors with liquid-air heat exchangers
- high winding temperature of generators and propulsion motors, where required (see [4.3])
- low lubricating oil pressure of bearings for machines with forced oil lubrication
- tripping of protective devices against overvoltages in semiconductor convertors (critical alarm)
- tripping of protection on filter circuits to limit the disturbances due to semiconductor convertors
- tripping of protective devices against overcurrents up to and including short-circuit in semiconductor convertors (critical alarm)
- voltage unbalance of three-phase a.c. systems supplied by semiconductor frequency convertors
- earth fault for the main propulsion circuit (see Note 2).
- earth fault for excitation circuits of propulsion machines (see Note 3).

Note 1: As an alternative to the air temperature of convertors or to the airflow, the supply of electrical energy to the ventilator or the temperature of the semiconductors may be monitored.

Note 2: In the case of star connected a.c. generators and motors with neutral points earthed, this device may not detect an earth fault in the entire winding of the machine.

Note 3: This may be omitted in brush less excitation systems and in the excitation circuits of machines rated up to 500 kW. In such cases, lamps, voltmeters or other means are to be provided to detect the insulation status under operating conditions.

4.5 Reduction of power

4.5.1 (1/7/2015)

Power is to be automatically reduced in the following cases:

- low lubricating oil pressure of bearings of propulsion generators and motors
- high winding temperature of propulsion generators and motors
- fan failure in machines and convertors provided with forced ventilation, or failure of cooling system
- lack of coolant in machines and semiconductor convertors
- load limitation of generators or inadequate available power.

Power is to be automatically reduced in the following cases.

4.5.2 (1/7/2015)

When power is reduced automatically, this is to be indicated at the propulsion control position (critical alarm).

4.5.3 (1/7/2015)

Switching-off of the semiconductors in the event of abnormal service operation is to be provided in accordance with the manufacturer's specification.

5 Installation

5.1 Ventilation of spaces

5.1.1 (1/7/2015)

Loss of ventilation to spaces with forced air cooling is not to cause loss of propulsion. To this end, two sets of ventilation fans are to be provided, one acting as a standby unit for the other. Equivalent arrangements using several independently supplied fans may be considered.

5.2 Cable runs

5.2.1 (1/7/2015)

Instrumentation and control cables are to comply with the requirements of Pt C, Ch 3, Sec 5 of the Rules for the Classification of Ships.

5.2.2 (1/7/2015)

Where there is more than one propulsion motor, all cables for any one machine are to be run as far as is practicable away from the cables of other machines.

5.2.3 (1/7/2015)

Cables which are connected to the sliprings of synchronous motors are to be suitably insulated for the voltage to which they are subjected during manoeuvring.

6 Tests

6.1 Test of rotating machines

6.1.1 (1/7/2015)

The test requirements are to comply with of Pt C, Ch 2, Sec 4 of the Rules for the Classification of Ships.

6.1.2 (1/7/2015)

For rotating machines, such as synchronous generators and synchronous electric motors, of a power of more than 3 MW, a test program is to be submitted to the Society for examination.

6.1.3 (1/7/2015)

In relation to the evaluation of the temperature rise, it is necessary to consider supplementary thermal losses induced by harmonic currents in the stator winding. To this end, two methods may be used:

- direct test method, when the electric propulsion motor is being supplied by its own frequency convertor, and/or back to back arrangement according to the supplier's facility
- indirect test method as defined in Pt C, Ch 2, App 1 of the Rules for the Classification of Ships; in this case a validation of the estimation of the temperature excess due to harmonics is to be documented. A justification based on a computer program calculation may be taken into consideration, provided that validation of such program is demonstrated by previous experience.

7 Specific requirements for PODs

7.1 General

7.1.1 (1/7/2015)

When used as steering manoeuvring system, the POD is to comply with the requirements of Sec 4, [2.5].

7.2 Rotating commutators

7.2.1 (1/7/2015)

As far as the electrical installation is concerned, the electric motor is supplied by a rotating commutator which rotates with the POD. The fixed part of the power transmission is connected to the unit supply, which uses the same components as a conventional propulsion system. Sliding contacts with a suitable support are used between the fixed and rotating parts.

7.2.2 (1/7/2015)

Type tests are to be carried out, unless the manufacturer can produce evidence based on previous experience indicating the satisfactory performance of such equipment on board units.

7.2.3 (1/7/2015)

A test program is to be submitted to the Society for examination. It is to be demonstrated that the power transmission and transmission of low level signals are not affected by the environmental and operational conditions prevailing on board. To this end, the following checks and tests are to be considered:

- check of the protection index (I.P.), in accordance with the location of the rotating commutator
- check of the clearances and creepage distances
- check of insulation material (according to the test procedure described in IEC 60112)
- endurance test:

After the contact pressure and rated current are set, the commutator is subjected to a rotation test. The number of rotations is evaluated taking into consideration the unit operation and speed rotation control system. The possibility of turning the POD 180° to proceed astern and 360° to return to the original position is to be considered. The commutator may be submitted to cycles comprising full or partial rotation in relation to the use of the POD as steering gear. The voltage drops and current are to be recorded.

An overload test is to be carried out in accordance with Pt C, Ch 2, Sec 4 (minimum 150%, 15 seconds) of the Rules for the Classification of Ships.

- check of the behaviour of the sliprings when subjected to the vibration defined in Pt C, Ch 3, Sec 6 of the Rules for the Classification of Ships

- check of the behaviour of the sliprings, after damp heat test, as defined in Part C, Chapter 3, and possible corrosion of the moving parts and contacts
After the damp heat test, are to be carried out the here-under listed tests.
- Insulation measurement resistance test. The minimum resistance is to be in accordance with Pt C, Ch 2, Sec 4, Tab 3 of the Rules for the Classification of Ships
- Dielectric strength test as defined in Pt C, Ch 2, Sec 4 of the Rules for the Classification of Ships.

7.3 Electric motors

7.3.1 (1/7/2015)

The thermal losses are dissipated by the liquid cooling of the bulb and by the internal ventilation of the POD. The justification for the evaluation of the heating balance between the sea water and air cooling is to be submitted to the Society.

Note 1: The calculation method used for the evaluation of the cooling system (mainly based on computer programs) is to be documented. The calculation method is to be justified based on the experience of the designer of the system. The results of scale model tests or other methods may be taken into consideration.

7.3.2 (1/7/2015)

Means to adjust the air cooler characteristics are to be provided on board, in order to obtain an acceptable temperature rise of the windings. Such means are to be set following the dock and sea trials. Means are to be provided to transmit the low level signals connected to the sensors located in the POD..

7.4 Instrumentation and associated devices

7.4.1 (1/7/2015)

Means are to be provided to transmit the low level signals connected to the sensors located in the POD.

7.5 Additional tests

7.5.1 (1/7/2015)

Tests of electric propulsion motors are to be carried out in accordance with Pt C, Ch 2, Sec 4 of the Rules for the Classification of Ships, and other tests in accordance with Sec 4, [2.1.2].

7.5.2 (1/7/2015)

Tests are to be performed to check the validation of the temperature rise calculation.

SECTION 7

AUTOMATION

1 General

1.1 Application

1.1.1 (1/7/2015)

The requirements in this Section apply to FPU in addition to those contained in Part C, Chapter 3.

2 Additional requirements for refrigerating plants

2.1 Remote control

2.1.1 (1/7/2015)

The requirements in Pt C, Ch 3, Sec 2, [3] of the Rules for the Classification of Ships apply to propulsion machinery.

2.1.2 (1/7/2015)

The design of the remote control system is to be such that in case of its failure an alarm will be given.

2.1.3 (1/7/2015)

Supply failure (voltage, fluid pressure, etc.) in propulsion plant remote control is to activate an alarm at the control position. In the event of remote control system failure and unless the Society considers it impracticable, the pre-set speed and direction of thrust are to be maintained until local control is in operation. This applies in particular in the case of loss of electric, pneumatic or hydraulic supply to the system.

2.1.4 (1/7/2015)

Propulsion machinery orders from the navigation bridge are to be indicated in the main machinery control room, and at the manoeuvring platform.

2.1.5 (1/7/2015)

The control is to be performed by a single control device for each independent propeller, with automatic performance of all associated services, including, where necessary, means of preventing overload of the propulsion machinery. Where multiple propellers are designed to operate simultaneously, they must be controlled by one control device.

2.1.6 (1/7/2015)

Indicators are to be fitted on the navigation bridge, in the main machinery control room and at the manoeuvring platform, for:

- propeller speed and direction of rotation in the case of fixed pitch propellers; and
- propeller speed and pitch position in the case of controllable pitch propellers.

2.1.7 (1/7/2015)

The main propulsion machinery is to be provided with an emergency stopping device on the navigation bridge which is to be independent of the navigation bridge control system. In the event that there is no reaction to an order to stop, provision is to be made for an alternative emergency stop. This emergency stopping device may consist of a simple and clearly marked control device, for example a push-button. This fitting is to be capable of suppressing the propeller thrust, whatever the cause of the failure may be.

2.2 Remote control from navigating bridge

2.2.1 (1/7/2015)

Where propulsion machinery is controlled from the navigating bridge, the remote control is to include an automatic device such that the number of operations to be carried out is reduced and their nature is simplified and such that control is possible in both the ahead and astern directions. Where necessary, means for preventing overload and running in critical speed ranges of the propulsion machinery is to be provided.

2.2.2 (1/7/2015)

On board units fitted with remote control, direct control of the propulsion machinery is to be provided locally. The local direct control is to be independent from the remote control circuits, and takes over any remote control when in use.

2.2.3 (1/7/2015)

Each local control position, including partial control (e.g. local control of controllable pitch propellers or clutches) is to be provided with means of communication with each remote control position. The local control positions are to be independent from remote control of propulsion machinery and continue to operate in the event of a blackout.

2.2.4 (1/7/2015)

Remote control of the propulsion machinery is to be possible only from one location at a time; at such locations interconnected control positions are permitted.

2.2.5 (1/7/2015)

The transfer of control between the navigating bridge and machinery spaces is to be possible only in the main machinery space or the main machinery control room. The system is to include means to prevent the propelling thrust from altering significantly, when transferring control from one location to another.

2.2.6 (1/7/2015)

At the navigating bridge, the control of the routine manoeuvres for one line of shafting is to be performed by a single control device: a lever, a handwheel or a push-button board. However each mechanism contributing directly to

the propulsion, such as the engine, clutch, automatic brake or controllable pitch propeller, is to be able to be individually controlled, either locally or at a central monitoring and control position in the engine room.

2.2.7 (1/7/2015)

Remote starting of the propulsion machinery is to be automatically inhibited if a condition exists which may damage the machinery, e.g. shaft turning gear engaged, drop of lubrication oil pressure or brake engaged.

2.2.8 (1/7/2015)

As a general rule, the navigating bridge panels are not to be overloaded by alarms and indications which are not required.

2.2.9 (1/7/2015)

At each control location there is to be an indicator showing which location is in control of propulsion machinery.

2.3 Automatic control

2.3.1 (1/7/2015)

The requirements in Pt C, Ch 3, Sec 2, [3] of the Rules for the Classification of Ships apply. In addition, the following requirements are to be considered, when relevant.

2.3.2 (1/7/2015)

Main turbine propulsion machinery and, where applicable, main internal combustion propulsion machinery and auxiliary machinery are to be provided with automatic shutoff arrangements in the case of failures such as lubricating oil supply failure which could lead rapidly to complete breakdown, serious damage or explosion.

2.3.3 (1/7/2015)

The automatic control system is to be designed on a fail safe basis, and, in the event of failure, the system is to be adjusted automatically to a predetermined safe state.

2.3.4 (1/7/2015)

When the remote control system of the propulsion machinery includes automatic starting, the number of automatic consecutive attempts is to be limited at a pre-set value of the starting air pressure permitting 3 attempts, and an alarm is to be provided, on the navigation bridge and in the machinery space.

2.3.5 (1/7/2015)

Operations following any setting of the bridge control device (including reversing from the maximum ahead service speed in case of emergency) are to take place in an automatic sequence and with acceptable time intervals, as prescribed by the manufacturer.

2.3.6 (1/7/2015)

For steam turbines, a slow turning device is to be provided which operates automatically if the turbine is stopped longer than admissible. Discontinuation of this automatic turning from the bridge is to be possible.

2.4 Automatic control of propulsion and manoeuvring units

2.4.1 (1/7/2015)

When the power source actuating the automatic control of propelling units fails, an alarm is to be triggered. In such case, the pre-set direction of thrust is to be maintained long enough to allow the intervention of engineers. Failing this, minimum arrangements, such as stopping of the shaft line, are to be provided to prevent any unexpected reverse of the thrust. Such stopping may be automatic or ordered by the operator, following an appropriate indication.

2.5 Clutches

2.5.1 (1/7/2015)

Where the clutch of a propulsion engine is operated electrically, pneumatically or hydraulically, an alarm is to be given at the control station in the event of loss of energy; as far as practicable, this alarm is to be triggered while it is still possible to operate the equipment.

2.5.2 (1/7/2015)

When only one clutch is installed, its control is to be fail-set. Other arrangements may be considered in relation to the configuration of the propulsion machinery.

2.6 Brakes

2.6.1 (1/7/2015)

Automatic or remote controlled braking is to be possible only if:

- propulsion power has been shut off
- the turning gear is disconnected
- the shaftline speed (r.p.m.) is below the threshold stated by the builder.

SECTION 8

SAFETY SYSTEMS

1 General

1.1 Purpose and application

1.1.1 (1/7/2015)

The requirements in this Section apply to FPU in addition to those contained in Part C, Chapter 3.

1.2 Documents to be submitted

1.2.1 (1/7/2015)

In addition to the documentation required in Section 9 the following are to be sent for approval:

- diagram of emergency shutdown circuits;
- cause and effects diagrams.

2 Fire and gas detection

2.1 General requirements

2.1.1 (1/7/2015)

Reference is to be made to the provisions laid down Sec 9, [3].

3 Emergency shutdown systems

3.1 General requirements and definitions

3.1.1 (1/7/2015)

The safest conditions for the systems on board are to be defined.

3.1.2 (1/7/2015)

All equipment and systems are to be equipped with indicating or monitoring instruments and devices necessary for safe operation.

3.1.3 (1/7/2015)

Emergency shutdown systems are to be provided against hazardous events.

Production systems are to be equipped with shutdown systems.

Systems that could endanger the safety if they fail or operate outside pre-set conditions are to be provided with automatic shutdown.

3.1.4 (1/7/2015)

An emergency shutdown system (ESD) includes:

- manual input devices (push buttons)

- interfaces towards other safety systems, e.g.:

- fire detection system
- gas detection system
- alarm and communication systems
- process shutdown system
- fire-fighting systems
- ventilation systems.

- a central control unit receiving and evaluating signals from the manual input devices and the interfaced systems, and creating output signals to devices that are to be shut down or activated. The ESD central control unit is to include a device providing visual indication of initiated inputs and activated outputs and a local audible alarm

- output actuators, e.g. relays, valves and dampers, including status indicators

- signal transfer lines between the ESD central control unit and all input devices, interfaced systems and output actuators

- power supply.

3.1.5 (1/7/2015)

In the context of these requirements under [3], 'circuit' is defined as any signal transfer facility, e.g. electrical, pneumatic, hydraulic, optical or acoustic.

3.1.6 (1/7/2015)

A normally energised circuit is a circuit where energy is present, e.g. an electrical current or pneumatic or hydraulic pressure, when the circuit is not activated by the shutdown system.

3.1.7 (1/7/2015)

A normally de-energised circuit is a circuit where energy is not present when the circuit is not activated by the shutdown system.

3.2 Basic design principles

3.2.1 (1/7/2015)

All shutdowns are to be executed in a predetermined logical manner. The shutdown system is normally to be designed in a hierarchical manner where higher level shutdowns automatically initiate lower level shutdowns.

3.2.2 (1/7/2015)

Definition of the shutdown logic and required response times are to be based on consideration of dynamic effects and interactions between systems.

3.2.3 (1/7/2015)

Shutdown is not to result in adverse cascade effects, which depends on activation of other protection devices to maintain a plant in a safe condition.

3.2.4 (1/7/2015)

The shutdown system is to be designed to ensure that any ongoing operations can be terminated safely when a shutdown is activated.

3.2.5 (1/7/2015)

Inter-trips between process systems are to be initiated as a result of any initial event which could cause undesirable cascade effects in other parts of the plant before operator intervention can be realistically expected.

3.2.6 (1/7/2015)

Emergency shutdown is to initiate a process shutdown.

3.2.7 (1/7/2015)

The shutdown system is to be completely independent of control systems used for normal operation. See also Pt C, Ch 3, Sec 2, [1.1.4] of the Rules for the Classification of Ships.

3.2.8 (1/7/2015)

The shutdown system is to be capable to monitor critical parameters and bring the system to a safe condition if specified conditions are exceeded. See also Pt C, Ch 3, Sec 2, [7] of the Rules for the Classification of Ships.

3.2.9 (1/7/2015)

The system is to be designed so that the risk of unintentional shutdown caused by malfunction or inadvertent operation is minimised.

3.2.10 (1/7/2015)

The system is to be designed to allow testing without interrupting other systems on board.

3.2.11 (1/7/2015)

The central control unit is to be located in a nonhazardous and continuously manned area.

3.2.12 (1/7/2015)

The system is to be powered from a monitored Uninterruptible Power Supply (UPS) capable of at least 30 minutes continuous operation on loss of its electrical power supply systems. The UPS is to be powered from both the main and the emergency power system.

3.3 Design and functional requirements

3.3.1 (1/7/2015)

Upon failure of the shutdown system, all connected systems are to default to the safest condition [3.1.1] for the unit or installation.

3.3.2 (1/7/2015)

Failures to be considered for the shutdown system are to include broken connections and short-circuits on input and output circuits, loss of power supply and, if relevant, loss of communication with other systems.

3.3.3 (1/7/2015)

For a shutdown system with only normally energized outputs, all inputs are to be normally energized.

3.3.4 (1/7/2015)

For a shutdown system with one or more normally de-energized outputs, all inputs able to activate a normally de-energized output are to be normally de-energized. All normally de-energized input and output circuits are to be monitored for broken connection and short-circuit.

3.3.5 (1/7/2015)

Shutdown is not to require unrealistically quick or complex intervention by the operator.

3.3.6 (1/7/2015)

Shutdowns on a hierarchical level are automatically to include shutdowns on lower levels.

3.3.7 (1/7/2015)

Shutdown is to initiate alarm at the control station. The initiating device and operating status of devices affected by the shutdown action are to be indicated at the control station (e.g. valve position, unit tripped, etc.).

3.3.8 (1/7/2015)

Personnel lifts, work platforms and other man-riding equipment are to be designed to enable safe escape after an emergency shutdown, e.g. by controlled descent to an access point on a lower level.

3.3.9 (1/7/2015)

Systems which are not permanently attended during operation, and which could endanger safety if they fail, are to be provided with automatic safety control, alert and alarm systems.

3.3.10 (1/7/2015)

Plants that are protected by automatic safety systems are to have pre-alarms to alert when operating parameters are exceeding normal levels.

3.3.11 (1/7/2015)

The shutdown commands are not to be automatically reset. In case local resets on shut down devices are provided, the indication of the shut down device status is to be given at the main control room.

3.4 Automatic and manual shutdown

3.4.1 (1/7/2015)

Shutdowns are normally to be automatically initiated, however solely manually initiated actions may be provided where automatic action could be detrimental to safety.

3.4.2 (1/7/2015)

Systems designed for automatic shutdown are also to be designed to enable manual shutdown.

3.4.3 (1/7/2015)

Alarms for manual initiation are to be clear and are to be readily identifiable at a permanently manned control station.

3.4.4 (1/7/2015)

In all shutdown systems, it is to be possible to manually activate all levels of shutdown at the control station.

3.4.5 (1/7/2015)

Other manual shutdown buttons are to be located at strategic locations on the unit or installation.

3.5 Electrical equipment for use in an emergency**3.5.1** (1/7/2015)

The following systems are to be operable after abandon unit shutdown:

- a) emergency lighting, for half an hour at:
 - every embarkation station on deck and over sides
 - in all service and accommodation alleyways, stairways and exits, personnel lift cars, and personnel lift trunks
 - in machinery spaces and main generating stations including their control positions
 - in all control stations and machinery control rooms.
- b) general alarm
- c) public address
- d) battery supplied radio-communication.

3.5.2 (1/7/2015)

Electrical equipment left operational after abandon unit shutdown is to be suitable for operation in zone 2 areas with the exceptions given in [3.3.7].

3.5.3 (1/7/2015)

Electrical equipment located in non-hazardous areas affected by a gas release, which is left operational after gas detection is to be suitable for zone 2, with the exceptions given in [3.3.7].

3.5.4 (1/7/2015)

Safety critical, uncertified electrical equipment may be left operational after ESD or gas detection affecting its area of location, provided that

- the ventilation to the room where the equipment is located is isolated
- gas detectors are installed in the room where the equipment is located
- facilities for manual shutdown of the equipment are available.

SECTION 9

FIRE PROTECTION, DETECTION AND EXTINCTION

1 General

1.1 Application

1.1.1 (1/7/2015)

This Section provides, for units having the service notation FPU, specific requirements for the active fire protection.

1.1.2 (1/7/2015)

The requirements of this Section, with the exception of items [3] are not applicable for the purpose of classification, except where the Society carries out surveys relevant to fire protection statutory requirements on behalf of the flag Administration. In such cases, fire protection statutory

requirements are considered a matter of class and therefore compliance with these requirements is also verified by the Society for classification purposes.

1.1.3 (1/7/2015)

Requirements contained in this Chapter are additional to those contained in Part C, Chapter 4, Section 2.

1.2 Documentation to be submitted

1.2.1 (1/7/2015)

In addition to those listed under Pt C, Ch 4, Sec 2, Tab 1 the documents listed in Tab 1 are to be submitted for approval.

Table 1 : Documents to be submitted (1/7/2015)

No	(1)	Document (2)
1	A	Fixed water deluge system
<p>(1) A : to be submitted for approval, in four copies</p> <p>(2) Plans are to be schematic and functional and to contain all information necessary for their correct interpretation and verification, such as:</p> <ul style="list-style-type: none"> • service pressures • capacity and head of pumps and compressors, if any • materials and dimensions of piping and associated fittings • surface areas of protected zones for automatic sprinkler and pressure water-spraying • capacity, in volume and/or in mass, of vessels or bottles containing the extinguishing media for automatic sprinkler, • type, number and location of nozzles of extinguishing media for automatic sprinkler, pressure water-spraying. <p>All or part of the information may be provided, instead of on the above plans, in suitable operating manuals or in specifications of the systems.</p>		

2 Active fire protection

2.1 Fixed fire extinguishing systems water demand

2.1.1 (1/7/2015)

When water deluge systems in item [2.2.1] are supplied by fire pumps, their capacity is to be in compliance with Chapter 4, Section 2, [5.1.1] and adequate to the worst fire scenario likely to be encountered. The scenario is to be evaluated upon case-by-case considerations, taking into account the actual lay-out of the production area of the unit.

2.1.2 (1/7/2015)

Based on item [2.1.1], the Society may request a calculation report, showing the criteria adopted for the design of the pumps.

2.2 Protection of production area

2.2.1 (1/7/2015)

Fixed water deluge system:

a) A fixed water deluge system for cooling, fire prevention and control is to be installed to protect:

- Processing areas and equipment
- Gas manifolds on deck
- Wellhead/Turret areas including swivel deck
- Well test areas

Gas handling equipment, such as gas compressor skids, the water spray system is not required if the equipment is provided with an automatic blowdown upon the process shutdown.

- b) The system is to be capable of covering all areas mentioned in a) with a uniformly distributed water spray of not less than:
- 10 l/m² per minute for processing areas;
 - 10 l/m² per minute for exposed surface of area of uninsulated vessels;
 - 6 l/m² per minute for exposed surface of area of insulated vessels;
 - 20 l/m² per minute for wellheads and turret areas.
- c) The system is to be capable of being actuated both automatically upon the activation of the fire detection system in item [2.2.2] and manually.
- d) The system may be divided into sections, taking into account the production equipment lay-out. Each section is to be isolated by a single valve. Valves are to be located in an accessible position outside the fire zone they protect.
- e) For each section identified in item d) above, the water deluge pumps are to be capable of supplying the section supposed to be in fire and the adjacent sections, for cooling and prevention purposes. Where suitable fire resistant divisions or adequate distance are displayed between sections, considerations may be made to exclude adjacent sections when calculating the minimum water supply capability.

2.2.2 Automatic fire detection and alarm system (1/7/2015)

An automatic fire detection and alarm system is to be installed in the areas listed in [2.2.1] a).

3 Fire and gas detection

3.1 Fire detection and alarm system

3.1.1 (1/7/2015)

An automatic fire detection and alarm system is to be installed in accommodation and service spaces, machinery spaces, air intakes of ventilation systems, production areas and in any space containing process equipment related to hydrocarbon or any other flammable liquids.

3.2 Gas detection system

3.2.1 (1/7/2015)

A fixed gas detection system is to be provided for the following areas:

- hazardous areas, except in Zone 0 and areas mechanically ventilated;
- ventilation outlets from hazardous areas mechanically ventilated;
- intakes for ventilation air, including those for accommodation spaces, service spaces and control stations.

3.2.2 (1/7/2015)

In cases where concentration of H₂S is expected, equipment suitable for measuring H₂S is to be installed. Visual and audible alarms are to be activated in the main control stations at 10 ppm H₂S.

4 Personnel protection

4.1 Firefighter's outfits

4.1.1 (1/7/2015)

Two fire fighter's outfits are to be provided, in addition to those required in Pt C, Ch 4, Sec 2, [5.7.2].

APPENDIX 1

IMPACT LOADS AND VORTEX SHEDDING

1 General

1.1 Application

1.1.1 (1/7/2015)

Structural members of the unit located within the zone subject to wave slamming are to be checked taking account of forces caused by the above wave slamming against their surface.

1.2 Wave slamming against horizontal members

1.2.1 (1/7/2015)

The slamming force may be calculated with the following equation:

$$\hat{F}_s = \frac{1}{2} \cdot \rho \cdot C_s \cdot A \cdot |\vec{v}_p| \cdot v_p$$

where:

- F_s : slamming force per unit length of the member, in N/m;
- ρ : mass density of water, in kg/m³;
- C_s : slamming coefficient;
- A : area, in profile view, (normal to the direction of the velocity of wave surface v_p) of the member per unit length of the latter in m²/m;
- v_p : velocity or wave surface normal to the surface of the member, in m/s,

The slamming coefficient C_s may be determined by means of theoretical or experimental methods.

For circular cylindrical members the value of C_s may be assumed equal to 1 in the absence of oscillations of the member concerned.

In the case of resonance between the natural frequency of the member and that of the exciting wave, the value of C_s is to be increased up to twice.

The wave slamming is also to be considered in the fatigue analysis. An applicable procedure for evaluating fatigue effects is outlined in App 2.

1.3 Impact from breaking waves

1.3.1 (1/7/2015)

Vertical members are not exposed to wave slamming but may be subject to shock pressure from breaking waves

The shock pressure per unit length of the member may be determined according to [1.2.1] and may be applied to a member length equal to 1/4 of the wave height H in N years.

Depending on the value of such pressure, in addition to the global effect on the member and on the unit, the effect of the local pressure p is to be considered. For circular cylindrical members, the local pressure p , to be taken for the local check, may be determined as shown in Fig 1.

The value of the impact velocity is given by the maximum horizontal velocity or water particles of a wave having height H and such a period as to break in correspondence of the actual water depth (see Sec 2, Fig 1).

The region to be investigated is that from the still water level to the wave crest.

2 Vortex shedding

2.1 General

2.1.1 (1/7/2015)

Wind, waves and current flow past a structural member may cause unsteady flow patterns due to vortex shedding which may lead to flexural vibrations of the member. This phenomenon may be dangerous when the vortex shedding frequency coincides with or is a multiple of the natural frequency of the member.

The vortex shedding frequency may be calculated with the following equation:

$$f_v = \frac{St \cdot v}{D}$$

where:

- f_v : vortex shedding frequency, in s⁻¹;
- St : Strouhal number;
- v : flow velocity normal to the member axis, in m/s;
- D : diameter (or equivalent dimension for non-circular cross-sectional shape members) of the member, in m.

The relationship between the Strouhal number St and the Reynolds number $Re = v \cdot D/\nu$, where ν is the kinematic viscosity of the fluid, in m²/s, for circular cylinder members, is given in Fig 2. The values of the Strouhal number St for sectional shapes other than circular cylinders, as a function of the wind direction, are given in Tab 1.

As a first approach, the resonant vortex shedding due to wind, waves and current flow are to be considered when the condition given in [2.2.1], [2.3.1] and [2.4.1] occur.

2.2 Vortex shedding due to wind

2.2.1 (1/7/2015)

- a) Flexural resonant vibrations of the member in line with the flow velocity of the wind may occur when:

$$1,7 \leq v_r \leq 3,2$$

where:

$$v_r : v / (f_i \cdot D) = \text{reduced velocity, in m/s;}$$

where:

$$f_i : \text{natural frequencies of the member vibrating in line with the flow velocity of wind, in s}^{-1};$$

$$v, D : \text{as defined in [2.1];}$$

- b) Cross flow flexural resonant vibrations of the member may occur when:

$$4,7 \leq v_r \leq 8,0$$

Figure 1 (1/7/2015)

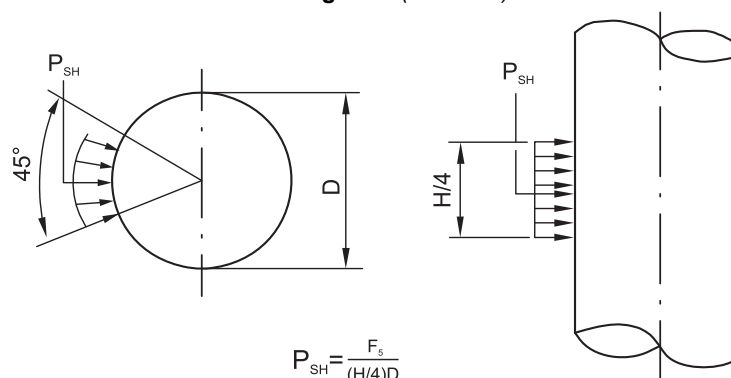

2.3 Vortex shedding due to steady current

2.3.1 (1/7/2015)

- a) Flexural resonant vibrations of the member in line with the flow velocity of the current may occur when:

$$1,2 < v_r < 3,5$$

$$k_s < 1,2$$

where:

v_r, D : as defined in [2.1] and [2.2];

where:

K_s : $m_e / (L \cdot \rho \cdot D^2)$ = stability parameter;

m_e : mass of the member per unit length, including the added mass, in kg/m;

ρ : mass density of water, in kg/m³.

- b) Cross flow flexural resonant vibrations of the member may occur when:

$$v_r \geq 3,5$$

$$k_s \geq 16$$

2.4 Vortex shedding due to waves

2.4.1 (1/7/2015)

Flexural resonant vibrations of the member in line with the flow excitation may occur when:

$$v_r \geq 1,0$$

$$KC \geq 3,0$$

where:

v_r : as defined in [2.2];

KC : $m_e / (v_m \cdot T) / D$ = Keulegan-Carpenter number;

v_m : maximum orbital velocity of fluid particles, in m/s;

T : wave period, in s;

D : as defined in [2.1].

2.5 Vortex shedding induced forces

2.5.1 (1/7/2015)

Vortex shedding induced forces may be calculated with the following equation:

$$F = \pm 0,5 \cdot \rho \cdot C_f \cdot D \cdot v^2$$

where:

F : force per unit length of the member, in N/m;

ρ, D : as defined in [2.1], [2.2] and [2.3];

C_f : fluctuating force coefficient;

V : flow velocity of fluid normal to the axis of the member, in m/s.

The values of the coefficient C_f may be found from the existing literature or from model tests and are in any case subject to approval by the Society. Figures 3 and 4 may be used as guidance for determining the transverse and in line fluctuating force coefficients C_f for smooth circular cylindrical members.

The value of the force calculated with equation above shall be increased when resonant vibrations of structural members are likely to occur (see [2.2], [2.3] and [2.4]), multiplying the above value by a dynamic amplification factor AD given by the following equation:

$$AD = \frac{1}{2\xi} \cdot (1 - e^{-2\pi n\xi})$$

where:

ξ : damping ratio, which may be taken equal to 0,005 for welded steel structures in air and equal to 0,02 for welded steel structures in water;

n : number of load cycles, which may be taken as infinite, if vortex shedding due to wind or steady current is considered; if vortex shedding due to waves is considered, n is the number of complete load cycles, in the time interval of half a wave period where the orbital velocity component normal to the axis of the member is within the range which can cause resonant vortex shedding.

Table 1 : Strouhal number for members of various cross-sectional shapes (1/7/2015)

Wind	Profile dimensions in mm	St	Wind	Profile dimensions in mm	St
→	<p>$t = 2,0$</p>	0,120	↓	<p>$t = 1,0$</p>	0,140
			↑		
→	<p>$t = 0,5$</p>	0,120	↓	<p>$t = 1,0$</p>	0,145
			↑		
↓	<p>$t = 1,0$</p>	0,144	→	<p>$t = 1,0$</p>	0,156
			↓		
↓	<p>$t = 1,5$</p>	0,145	-	<p>Cylinder 11800 <math>Re < 19100</math></p> <p>50</p>	0,200

Wind	Profile dimensions in mm	St	Wind	Profile dimensions in mm	St
↓		0,147	→		0,121
			↓		0,143
↓		0,150	→		0,135
←		0,145	→		0,160
↑		0,142			
↙		0,147			
←		0,131	→		0,114
		0,134			
↙		0,137	↑		0,145

Figure 2 : Strouhal number for smooth cylindrical members (1/7/2015)

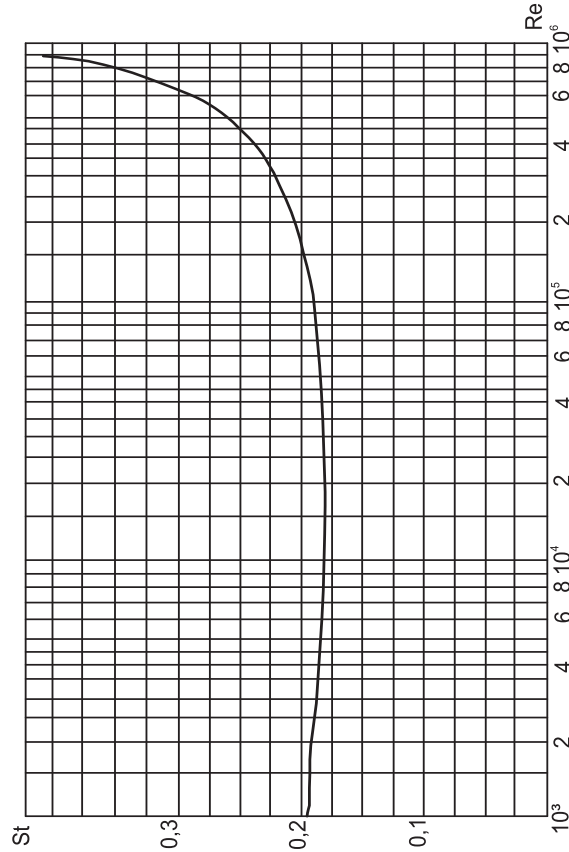

Figure 3 : Fluctuating in line force coefficient C_f for smooth cylindrical members (1/7/2015)

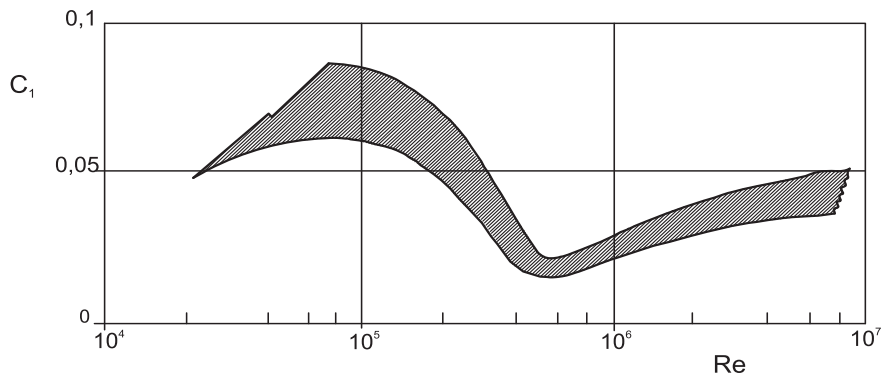
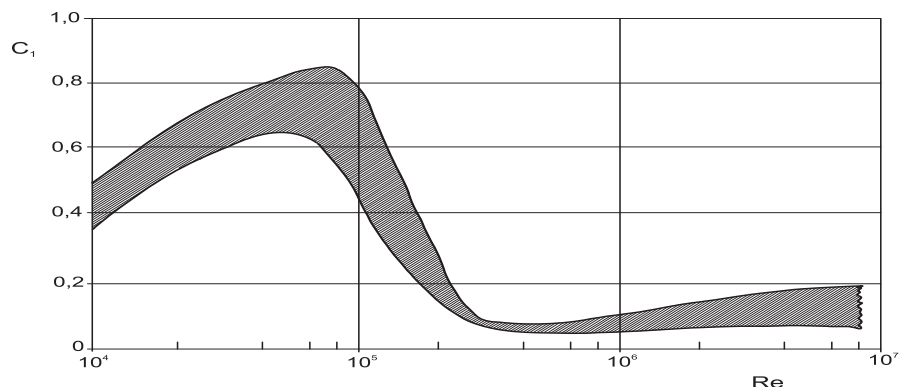

Figure 4 : Fluctuating cross-flow force coefficient C_f for smooth cylindrical members (1/7/2015)



APPENDIX 2

FATIGUE ANALYSIS WITH DETERMINATION OF THE CUMULATIVE DAMAGE

1 General

1.1 Application

1.1.1 (1/7/2015)

This method includes the following steps:

- determination of long term distribution of stress range;
- selection of an appropriate fatigue curve (S-N curve);
- determination of the cumulative damage.

2 Determination of long term distribution of stress range

2.1 General

2.1.1 (1/7/2015)

All stress fluctuations which during the entire life of the unit may cause damage due to fatigue are to be considered.

Such fluctuations may be caused by:

- direct and indirect (vortex shedding) actions of waves
- wind
- current
- operational loads
- machinery.

The wave induced forces are generally the main cause of damage to structures due to fatigue.

2.1.2 (1/7/2015)

The effects of dynamic response of structures are to be properly accounted for, if significant; special care is to be taken to adequately determine the stress ranges in members excited in ranges close to resonance range.

2.1.3 (1/7/2015)

As most of the loads which contribute to fatigue are of a random nature, the determination of the long term distribution of stress range may be performed either with spectral analysis or with deterministic analysis. Both the method of analysis and the relevant basic assumptions are subject to approval by the Society.

In the determination of the long term distribution of stress range, a sufficient number of combinations of environmental conditions (waves, wind and current) including their direction and associated probability of occurrence are to be taken into account.

2.1.4 (1/7/2015)

In the case of structures with linear response to wave excitations and of wave height distribution according to the Rayleigh distribution, the long term distribution of stress range of each structural detail can be approximately described by a straight line joining in a semi-logarithmic diagram ($\log N$,

$\Delta \sigma$) (see Fig 1), the point $(0, \Delta \sigma_{\max})$ with the point $(\log N_{\max}, 0)$, where:

$\Delta \sigma_{\max}$: maximum stress range induced on the structural element concerned by a wave having a recurrence period equal to the life of the structure;

N_{\max} : number of wave cycles corresponding to the life the structure.

3 Fatigue curve (S-N curve)

3.1

3.1.1 (1/7/2015)

The fatigue strength of a structural element is normally given as an S-N curve, i.e. stress versus number of cycles to failure.

The above curve is to be applicable to the material employed, the constructional details, the mean stress level and environmental conditions considered and the corrosion protection system adopted.

3.1.2 (1/7/2015)

In the case of an S-N curve which does not take into account stress concentrations due to the particular geometrical configuration of the structural element concerned, for the determination of the cumulative damage the nominal stress amplitudes, constituting the long term distribution, shall be multiplied by a suitable stress concentration factor.

The values of stress concentration factors are to be obtained either from the existing technical literature or from sophisticated structural strength calculations of the element concerned or from model tests.

3.1.3 (1/7/2015)

The S-N curves and the values of the stress concentration factors adopted are to be submitted to the Society for approval.

4 Determination of the cumulative damage

4.1

4.1.1 (1/7/2015)

The cumulative damage due to fatigue may be determined according to the Palmgren-Miner method which implies that the long term distribution of stress range is replaced by a stress histogram consisting of an adequate number R of constant amplitude ($\Delta \sigma_i$) stress range blocks.

According to the above method, the cumulative damage ratio η is given by the following equation:

where:

$$\eta = \sum_{i=1}^R n_i / N_i$$

n_i : number of stress cycles in stress block i ;
 N_i : number of cycles to fatigue failure at constant amplitude $\Delta\sigma_i$ stress range.

The number of stress blocks R is to be large enough to ensure reasonable numerical accuracy and in general is not to be less than 20.

4.1.2 (1/7/2015)

Fig 2 schematically shows the procedure to be followed for the determination of the cumulative damage ratio η .

4.1.3 (1/7/2015)

For horizontal structural members within the splash zone, the fatigue analysis is to include the contribution to fatigue from wave slamming, which may be evaluated according to the procedure shown in Fig 3, which implies the following steps:

- the minimum wave height H_{min} which can cause slamming is determined;
- the long term distribution of wave heights in excess of H_{min} is divided into a reasonable number of blocks;
- for each block, the stress range is taken as:

$$\Delta\sigma_i = 2[a\sigma_{imp} - (\sigma_b + \sigma_r)]$$

where:

σ_{imp} : stress in the member due to slam load;
 σ_r : stress due to net buoyancy force on the member;
 σ_w : stress due to vertical wave forces on the member;

A : dynamic amplification coefficient:
 $a = 1,5$ if the member end is considered;
 $a = 2,0$ if the member mid-span is considered.

- each slam is associated with 20 linearly decaying stress ranges;
- the contribution to fatigue from each wave block η_j is calculated by the following equation:

$$\eta_j = F_r(n_j/N_j) \sum_{i=20-n_r}^{20} (i/20)^k$$

where:

n_j : number of waves within the block j ;
 N_j : number of cycles to fatigue failure at constant stress amplitude $\Delta\sigma_j$;
 n_r : number of cycles associated with the cut off level of the S-N curve;
 F_r : reduction factor connected with the direction of wave origin. Assuming that a given member is only subject to impact from waves within a sector of 10° to each side of the perpendicular to the member axis, and assuming the direction of wave origin to be equiprobable, F_r has the following value:

$$F_r = (1/180) \cdot 20 \approx 0,11$$

K : slope of the S-N curve.

4.1.4 (1/7/2015)

In the absence of a detailed analysis of the effects of combined fatigue due to simultaneous high frequency stress cycles from slamming and low frequency stress cycles from other loads, the contribution to fatigue due to slamming is to be added conservatively to the fatigue contribution of other variable loads mentioned in [4.1.1].

Figure 1 (1/7/2015)

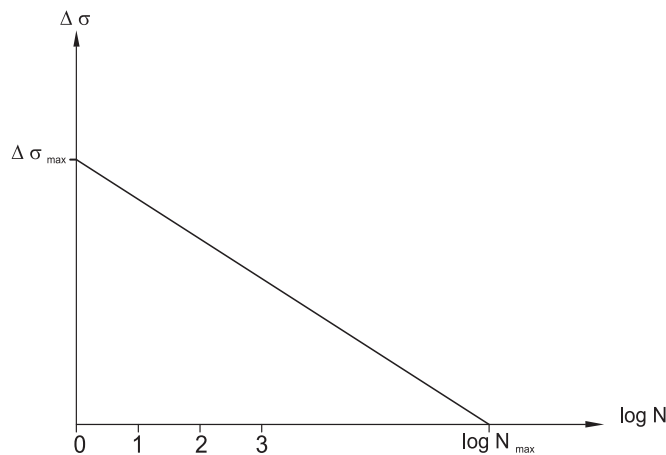

Figure 2 (1/7/2015)

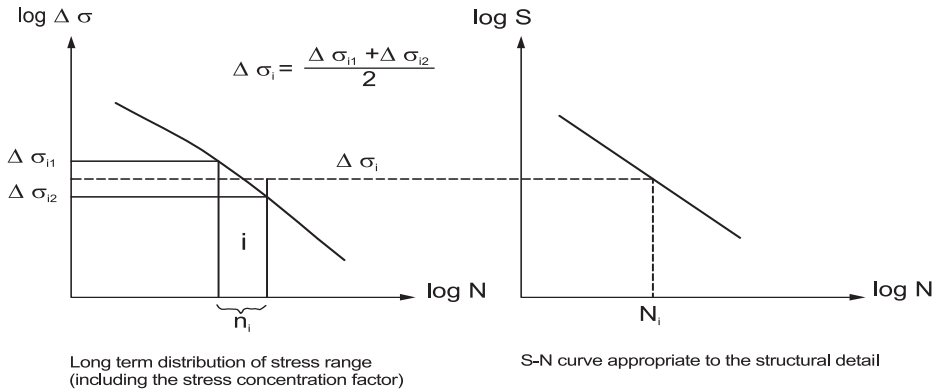
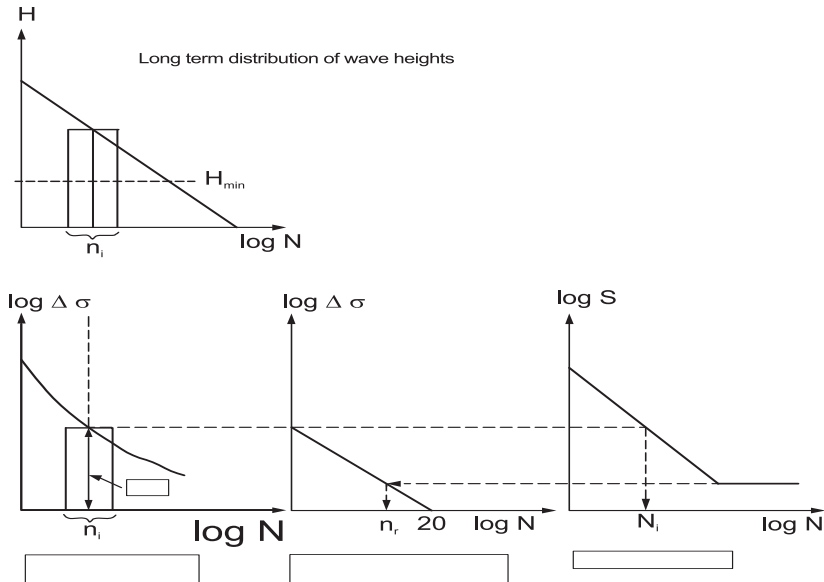

Figure 3 (1/7/2015)



APPENDIX 3

AN EXAMPLE OF ALTERNATIVE CRITERIA FOR A RANGE OF POSITIVE STABILITY AFTER DAMAGE OR FLOODING FOR COLUMN-STABILIZED SEMI-SUBMERSIBLE UNITS

1 General

1.1 Application

1.1.1 (1/7/2015)

The criteria hereunder constitute an alternative to those in item Sec 3, [5.2.1] c) and Sec 3, [5.2.2] c). These criteria apply only to column-stabilized semisubmersible units which have buoyant volumes contained in watertight upper-deck structure.

1.1.2 (1/7/2015)

The righting lever curve after damage or flooding, as set out in items Sec 3, [6.3] and in Sec 3, [5.2.2] respectively, is, before the second intercept angle, to reach a value of at least 2,5 m (see Fig 1). At least 1,0 m of this righting lever is to arise from enclosed watertight flats positioned at, or above, the lowest continuous deck.

1.1.3 (1/7/2015)

The righting lever curve after damage or flooding, as set out in items Sec 3, [6.3] and in Sec 3, [5.2.2] respectively, is to have a positive range of at least 10° between the first and second intercept.

1.1.4 (1/7/2015)

For the purposes of calculating the righting lever curve, buoyancy may be assumed from all spaces which are closed as described in items [1.1.5] and [1.1.6] below. If the lower edge of any opening which is not closed as required in items [1.1.5] and [1.1.6] is submerged, then the corresponding space is to be excluded from the buoyancy beyond the angle where this opening is submerged, but it to be included up to the angle where this opening is submerged. Any such loss of buoyancy is not to cause the righting lever to fall below 1,0 m above the wind lever curve within the range specified in item [1.1.3].

1.1.5 (1/7/2015)

Any opening submerged before the angle at which the righting lever required in item [1.1.3] is reached is to be fitted with a remotely operated watertight means of closure. Means of closure of a self activating type may also be accepted by the Society.

1.1.6 (1/7/2015)

Any opening submerged after the angle referred to in item [1.1.5] is reached and within the range specified in item [1.1.3] is to be fitted with means of closure as required in item [1.1.5] or with easily operable weathertight means of closure.

Figure 1

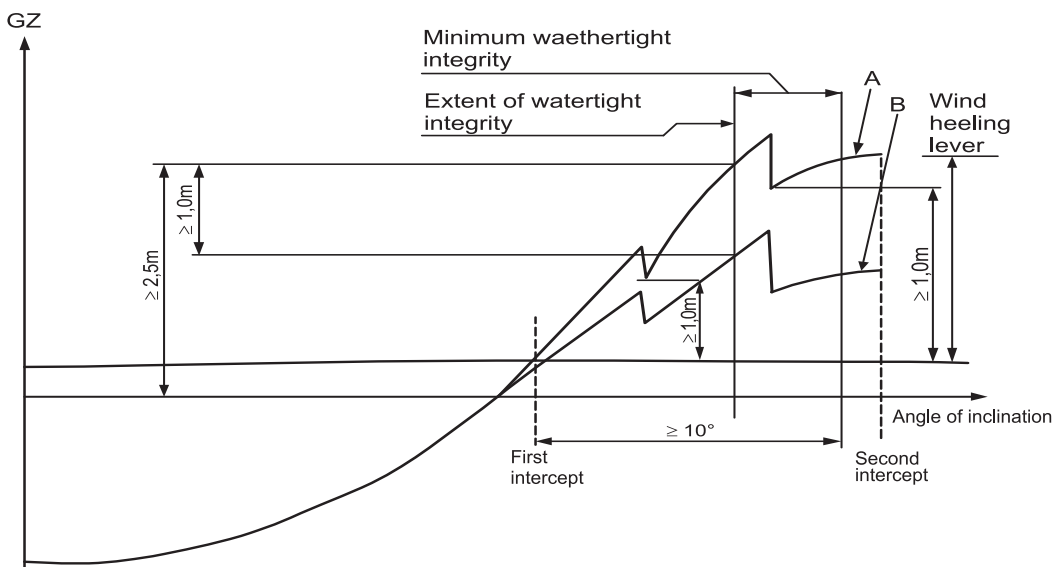

A - GZ-curve including enclosed volumes above watertight flats at or above the lowest continuous deck

B - GZ-curve excluding enclosed volumes above watertight flats at or above the lowest continuous deck

APPENDIX 4

AN EXAMPLE OF ALTERNATIVE CRITERIA INTACT STABILITY CRITERIA FOR TWIN-PON- TOON COLUMN-STABILIZED SEMISUBMERSIBLE UNITS

1 General

1.1 Application

1.1.1 (1/7/2015)

The criteria hereunder constitute alternative intact stability criteria for column-stabilized units under the provisions of item Sec 3, [4.1.3]. These criteria apply only to twin-pontoon column-stabilized semisubmersible units in severe storm conditions which fall within the following range of parameters:

N_p/V_T : is between 0,48 and 0,58

A_{WP}/V_C : is between 0,72 and 1,00

$I_{WP}/[V_C(L_{PTN/2})]$: is between 0,40 and 0,70 The parameters used in the above equations are defined in item [3].

2 Intact stability

2.1

2.1.1 (1/7/2015)

The stability of a unit in the survival mode of operation should meet the following criteria:

a) Capsize criteria

These criteria are based on the wind heeling moment and righting moment curves, calculated as shown in item Sec 3, [3], at the survival draught. The reserve energy area B must be greater than 10% of the dynamic response area A as shown in Fig 1.

$\text{Area B} / \text{Area A} > 0,10$

where:

- Area A is the area under the righting arm curve measured from θ_1 to $(\theta_1 + 1,15 \theta_{dyn})$
- Area B is the area under the righting arm curve measured from $(\theta_1 + 1,15 \theta_1)$ to θ_2
- θ_1 is the first intercept with the 100 knot wind moment curve
- θ_2 is the second intercept with the 100 knot wind moment curve
- θ_{dyn} is the dynamic response angle due to waves and fluctuating wind
 - $\theta_{dyn} = (10,3 + 17,8 C) / [1 + GM / (1,46 + 0,28 BM)]$
 - $C = (L_{PTN}^{5/3} * VCP_{w1} * A_w * V_p * V_c^{1/3}) / (I_{wp}^{5/3} * VT)$

Parameters used in the above equations are defined in item [3].

b) Downflooding criteria

These criteria are based on the physical dimensions of the unit and the relative motion of the unit about a static inclination due to a 75 knot wind measured at the survival draught. The initial downflooding distance (DFD0) must be greater than the reduction in downflooding distance at the survival draught as shown in Fig 2.

$DFD_0 - RDFD > 0,0$

where:

DFD_0 : initial downflooding distance to D_m in metres

$RDFD$: reduction in downflooding distance in metres = $SF (k \cdot QSD_1 + RMW)$

SF : which is a safety factor to account for uncertainties in the analysis, such as non-linear effects

K : correlation factor = $0,55 + 0,08 (a - 4,0) + 0,056 (1,52 - GM)$

a : $(FBD_0/D_m) (S_{PTN} \cdot L_{ccc}) / A_{wp}$
(a cannot be less than 4,0)
(GM cannot be greater than 2,44 m)

QSD_1 : $DFD_0 - \text{quasi-static downflooding distance at } \theta_1$, in metres, but not to be taken less than 3,0 m

RMW : relative motion due to waves about θ_1 , in metres = $9,3 + 0,11 (X - 12,19)$

X : $D_m (V_T / V_P) (A_{WP2} / I_{WP}) (L_{CC} / L_{PTN})$
(X cannot be taken to be less than 12,19 m)

The parameters used in the above equations are defined in item [3].

3 Geometric parameters

3.1

3.1.1 (1/7/2015)

A_{WP} : is the waterplane area at the survival draught including the effects of bracing members as applicable, in m^2

A_w : is the effective wind area with the unit in the upright position (i.e. the product of projected area, shape coefficient and height coefficient), in m^2

BM : is the vertical distance from the metacentre to the centre of buoyancy with the unit in the

- upright position, in m is the initial survival draught, in m
- D_m : is the initial survival draught, in m
- FDB_0 : is the vertical distance from D_m to the top of the upper exposed weathertight deck at the side, in m
- GM : for item [2.1.1], GM is the metacentric height measured about the roll or diagonal axis, whichever gives the minimum restoring energy ratio B/A . This axis is usually the diagonal axis as it possesses a characteristically larger projected wind area which influences the three characteristic angles mentioned above
- GM : for item [2.1.2], GM is the metacentric height measured about the axis which gives the minimum downflooding distance margin (i.e, generally the direction that gives the largest QSD1), in m
- I_{WP} : is the waterplane second moment of inertia at the survival draught including the effects of bracing members as applicable, in⁴
- I_{CCC} : is the longitudinal distance between centres of the corner columns, in m
- I_{PTN} : is the length of each pontoon, in m
- S_{PTN} : is the transverse distance between the centre-line of the pontoons, in m
- V_C : is the total volume of all columns from the top of the pontoons to the top of the column structure, except for any volume included in the upper deck, in m³
- V_P : is the total combined volume of both pontoons, in m³
- V_T : is the total volume of the structures (pontoons, columns and bracings) contributing to the buoyancy of the unit, from its baseline to the top of the column structure, except for any volume included in the upper deck, in m³
- VCP_{W1} : is the vertical centre of wind pressure above D_m in m.

Figure 1 : Righting moment and heeling moment curves (1/7/2015)

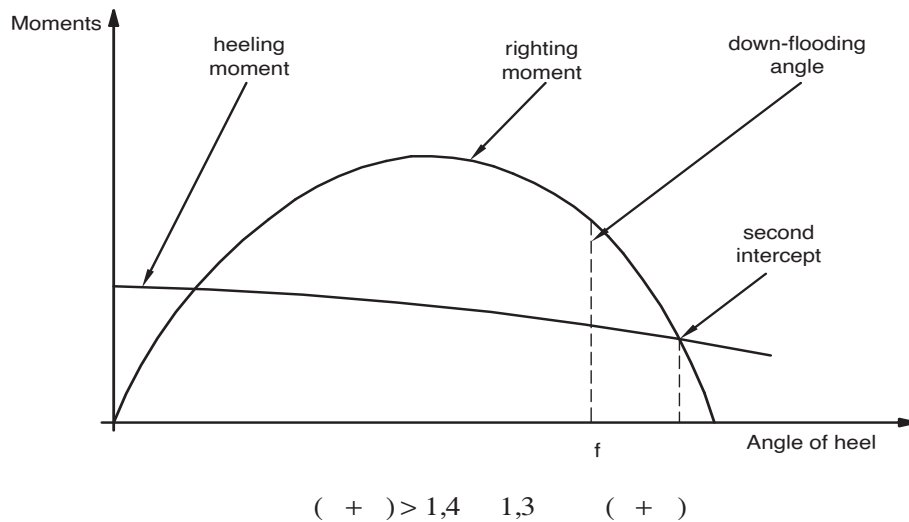

Figure 2 : Definition of downflooding distance and relative motion (1/7/2015)

